

MESSRS. 客戶公司行號

SPECIFICATION FOR APPROVAL

承 認 書

Product	ELECTRO MAGNETIC BUZZER (SELF)
Part No.	BUAI-10H3C
Customer Approval	
Customer Part No.	

Approved By	Checked By	Made By
 <p>工程部 BOB CHEN MAY-21-2020</p>	 <p>工程部 HANK CHEN MAY-21-2020</p>	 <p>工程部 ZACK KUO MAY-21-2020</p>

FLYiNG 汎翊國際有限公司
www.flying1688.com

RoHS

1. SPECIFICATION

BUAI-10H3C

ITEM		UNITS	SPECIFICATIONS	CONDITIONS
01	Rated Voltage	V	3	
02	Operating Voltage	V	2~5	
03	Consumption Current	mA (Max)	30	Rated Voltage
04	Resonant Frequency	Hz	2700± 300	Rated Voltage
05	Response times	ms	≥ 100	
06	Sound pressure level	dB(A) Min.	80	Distance at 10cm Rated Voltage / Resonant Frequency
07	Operating Temp.	°C	-40 ~ +85	
08	Storage Temp.	°C	-40 ~ +85	
09	Weight	g	1 ±0.3	

2. MEASURING METHOD

2-1. Test Condition

STANDARD

Temperature : 15 ~ 35°C

Relative humidity : 25% ~ 85%,

Atmospheric pressure: 860mbar to 1060mbar.

JUDGEMENT

Temperature : 20±3°C

Relative humidity : 60% ~ 70%,

Atmospheric pressure : 860mbar to 1060mbar

2-2. Standard Test Fixture

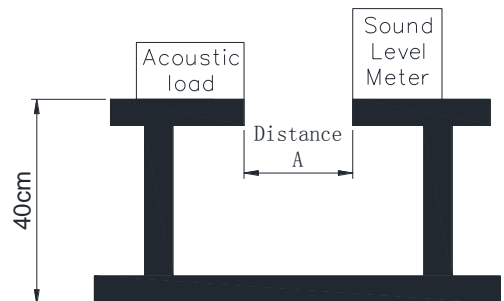

2-3. SPL Curve (For Reference Only)

Test distance : **A=10 cm**

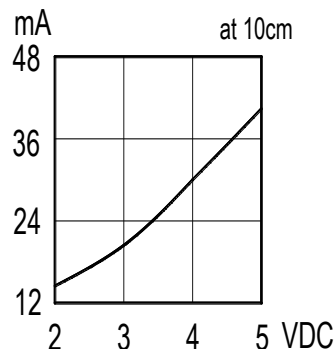
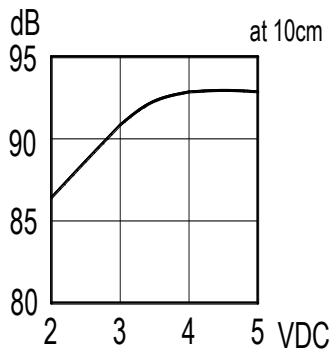

2-4. Recommend drive circuit

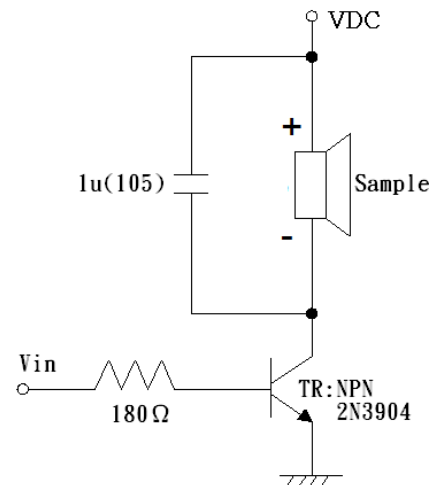

3. DIMENSIONS

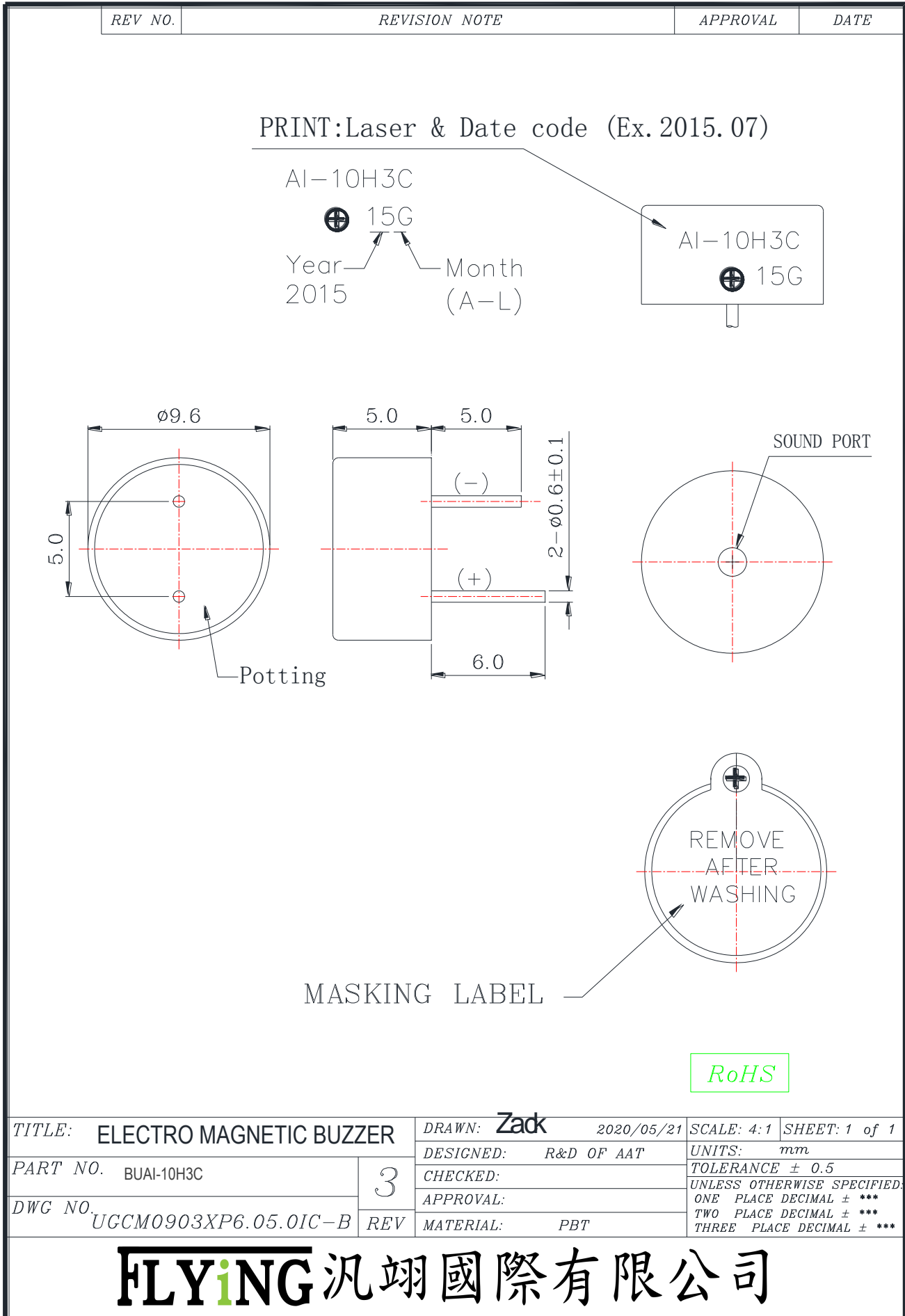

4. RELIABILITY TESTS

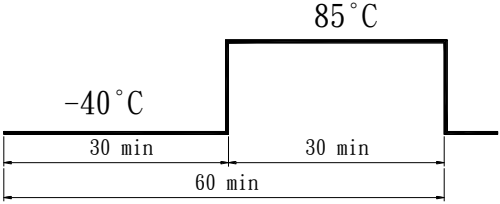
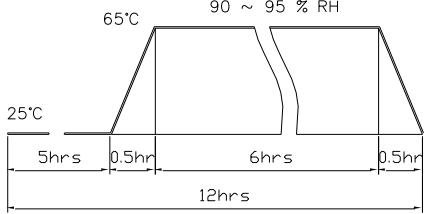
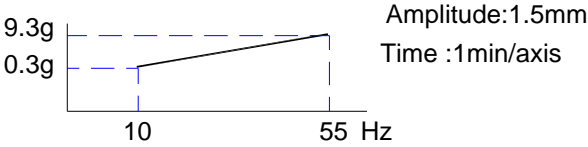
Item	Test conditions	Evaluation standard
01 High temp. Storage life	The part shall be capable of withstanding a storage Temperature of +85°C for 96 hours.	<p>1. After the test the part shall meet specifications without Any degradation in appearance and performance except S.P.L</p> <p>2. S.P.L shall be ±7 dB.</p>
02 Low temp. Storage life	The part shall be capable of withstanding a storage Temperature of -40°C for 96 hours.	
03 Temp. cycle	<p>The part shall be subjected 10 cycles. One cycle shall of ;</p> 	
04 Temp./Humidity cycle	<p>The part shall be subjected 10 cycles. One cycle shall of;</p> 	
05 Operating life	<p>Rated Voltage, Frequency applied.</p> <ol style="list-style-type: none"> Ordinary temperature The part shall be subjected to 1000 hours at room temperature (25 ±10°C) High temperature The part shall be subjected to 500 hours at 70°C Low temperature The part shall be subjected to 500 hours at -30°C 	
06 Vibration	 <p>Make this test for the directions of X, Y, Z for 2 hours each (total 6 hours).</p>	
07 Lead strength	Pull lead with a force of 9.8N, on the direction of the lead axis for 10 :10±1 sec	

Item		Test conditions	Evaluation standard
08	Free drop	The part only shall be dropped from a height of 75cm onto a 40mm thick wooden board 1 times in 3 Direction each (X.Y.Z). (a total of 3 times).	1. After the test the part shall meet specifications without Any degradation in appearance and performance except S.P.L 2. S.P.L shall be ± 7 dB.
	Free drop (Packing)	The part only shall be dropped from a height of 100cm onto a 10mm thick wooden board 1 times in 3 axes (X.Y.Z). (a total of 3 times).	

5. CAUTIONS FOR USE

01	<p>As this product is not protected from foreign material entering, please make sure that any foreign materials do not enter this product in your production processes. (e.g. magnetic powder, washing solvent, flux, corrosive gas)</p> <p>由於本產品不能防止異物進入，請確保任何異物不會在生產過程中進入本產品。 (例如磁粉，洗滌溶劑，焊劑，腐蝕性氣體)</p>
02	<p>The functional degradation may occur if foreign material enter it. (e.g. SPL down)</p> <p>如果外來物質進入，則可能發生功能退化。(例如 SPL 下降)</p>
03	<p>Wash ability Solvent : deionizer water Solvent temp. : $55\pm 5^{\circ}\text{C}$ Soaking time : 5 ± 0.5 min. After the washing process, be sure to tear off the label.</p> <p>耐洗性 溶劑：去離子水 溶劑溫度：$55\pm 5^{\circ}\text{C}$ 浸泡時間：5 ± 0.5 分鐘。 在洗滌過程後，一定要撕下標籤。</p>
04	<p>After solder bath, the cooling time must be longer than 2 hours before function test.</p> <p>測試功能前，必須在過完錫爐後並冷卻 2 小時以上。</p>
05	<p>Soldering profile Soldering into solder bath: $250\pm 5^{\circ}\text{C}$, 5 ± 1 Sec. 爐溫曲線</p>

錫爐溫度: $250 \pm 5^{\circ}\text{C}$, 5 ± 1 Sec.

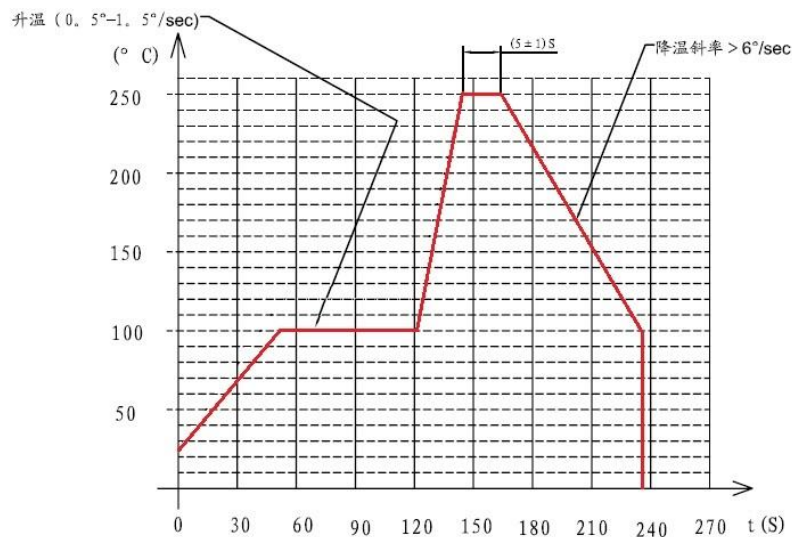

Soldering with iron

Hand Soldering : $360 \pm 10^{\circ}\text{C}$ / ≤ 2 Sec.

06 Recommend using constant searing-iron

焊接

手焊: $360 \pm 10^{\circ}\text{C}$ / ≤ 2 Sec.

建議使用烙鐵

07 improvements.

FLYING reserves the right to change product material without prior notice, guaranteeing the same specification. Materials are subject to change due to environmental regulations, sourcing, and process

材料可能由於環境法規，物料及製程工藝精進而發生變動，FLYING 保證相同的規格，並有權保留更改產品材料的權利，恕不另行通知。

08 If you need more information, please contact our technology department, thank you

如您需要更多信息，請聯繫我們的技術部門，謝謝。

6. PACKING

