



ULVH431

LINEAR INTEGRATED CIRCUIT

LOW-VOLTAGE ADJUSTABLE PRECISION SHUNT REGULATOR

DESCRIPTION

The UTC **ULVH431** is a low-voltage 3-terminal programmable shunt regulator with guaranteed thermal stability over full applicable industrial and commercial temperature ranges.

The output voltage of UTC **ULVH431** can be set to any value between V_{REF} (1.24V) and the corresponding maximum cathode voltage (18V) with two external resistors.

The UTC **ULVH431** is an ideal voltage reference in isolated feedback circuits for 3-V to 3.3-V switching-mode power supplies when it is used with an opto-coupler. It has a typical output impedance of 0.25Ω . Active output circuitry supplies a very sharp turn-on characteristic, which makes the UTC **ULVH431** very good substitute for low-voltage Zener diode in many applications such as adjustable power supplies and on-board regulation.

FEATURES

- * Adjustable output voltage, $V_O = V_{REF}$ to 18 V
- * Low-Voltage operation: $V_{REF} = 1.24$ V
- * Wide operating cathode current range: 100 μ A to 50mA
- * Reference voltage tolerances at 25°C
- * 0.25- Ω typical output impedance
- * -40°C ~ 125°C specifications

ORDERING INFORMATION

| Ordering Number | | Package | Packing |
|------------------|------------------|----------|-----------|
| Lead Free | Halogen Free | | |
| ULVH431L-AE2-R | ULVH431G-AE2-R | SOT-23-3 | Tape Reel |
| ULVH431L-AE3-R | ULVH431G-AE3-R | SOT-23 | Tape Reel |
| ULVH431NSL-AE3-R | ULVH431NSG-AE3-R | SOT-23 | Tape Reel |
| ULVH431L-AE5-R | ULVH431G-AE5-R | SOT-23-5 | Tape Reel |
| ULVH431L-AF5-R | ULVH431G-AF5-R | SOT-25 | Tape Reel |

Note: Pin Code: R: Reference K: Cathode A: Anode

| | |
|--|---|
| <p>ULVH431G-AE3-R</p> <p>(1) Packing Type (2) Package Type (3) Green Package</p> | <p>(1) R: Tape Reel (2) AE2: SOT-23-3, AE3: SOT-23, AE5: SOT-23-5 AF5: SOT-25 (3) G: Halogen Free and Lead Free, L: Lead Free</p> |
|--|---|

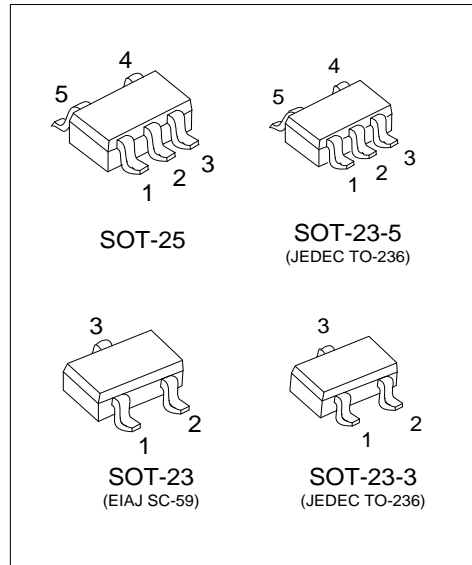

ULVH431

LINEAR INTEGRATED CIRCUIT

MARKING

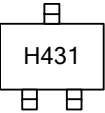
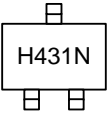
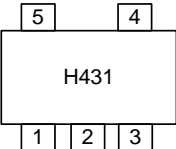
| | | |
|---|---|---|
| SOT-23-3/SOT-23 (ULVH431) | SOT-23-3/SOT-23 (ULVH431NS) | SOT-23-5/SOT-25 |
|  |  |  |

PIN CONFIGURATION

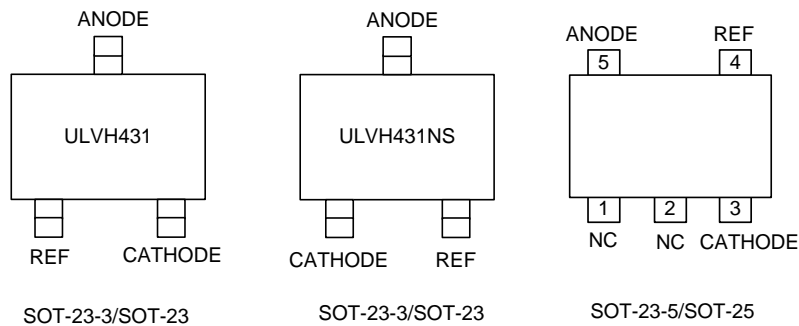

PIN DESCRIPTION

| PIN NO. | | SOT-23-5/SOT-25 | PIN NAME | DESCRIPTION |
|----------------------------|------------------------------|-----------------|----------|-------------------|
| SOT-23-3/SOT-23 ULVH431 | SOT-23-3/SOT-23 ULVH431NS | | | |
| 1 | 2 | 4 | REF | Reference voltage |
| 2 | 1 | 3 | CATHODE | Cathode voltage |
| 3 | 3 | 5 | ANODE | Anode voltage |
| - | - | 1, 2 | NC | No Connection |

BLOCK DIAGRAM

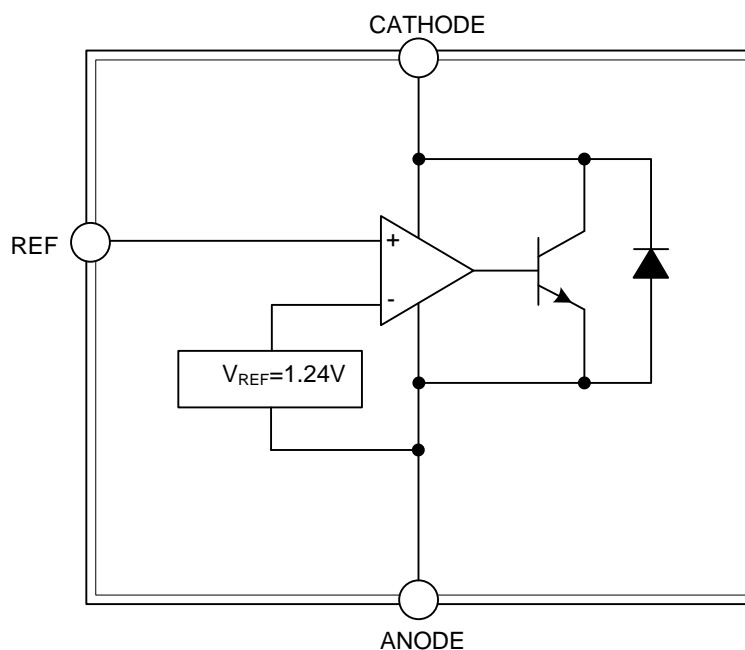

■ ABSOLUTE MAXIMUM RATING

| PARAMETER | SYMBOL | RATINGS | UNIT |
|--|-----------|------------|------|
| Cathode Voltage (Note 1) | V_{KA} | 20 | V |
| Cathode Current Range | I_K | 50 | mA |
| Reference Current Range | I_{REF} | -0.05 ~ 3 | mA |
| Operating Virtual Junction Temperature | T_J | +150 | °C |
| Operating Temperature (Note 2) | T_{OPR} | -40 ~ +125 | °C |
| Storage Temperature Range | T_{STG} | -65 ~ +150 | °C |

Notes: 1. Absolute maximum ratings are those values beyond which the device could be permanently damaged.

Absolute maximum ratings are stress ratings only and functional device operation is not implied.

2. It is guarantee by design, not 100% be tested.

■ THERMAL RESISTANCES CHARACTERISTICS

| PARAMETER | SYMBOL | RATINGS | UNIT |
|---------------------------|---------------|---------|------|
| Package Thermal Impedance | θ_{JA} | 325 | °C/W |

■ RECOMMENDED OPERATING CONDITIONS

| PARAMETER | SYMBOL | MIN | TYP | MAX | UNIT |
|--------------------------------------|----------|-----------|-----|-----|------|
| Cathode Voltage | V_{KA} | V_{REF} | | 18 | V |
| Cathode Current (Continuous) | I_K | 0.1 | | 50 | mA |
| Operating Free-Air Temperature Range | T_A | -40 | | 125 | °C |

■ ELECTRICAL CHARACTERISTICS ($T_A=25^\circ\text{C}$ free-air temperature, unless otherwise specified)

| PARAMETER | SYMBOL | TEST CONDITIONS | | MIN | TYP | MAX | UNIT | |
|---|--|--|------------------------|---------------------------|-------|------|---------------|---|
| Reference Voltage | V_{REF} | $V_{KA}=V_{REF}$, $I_K=10\text{mA}$ | $T_A=25^\circ\text{C}$ | ULVH431-A ($\pm 0.5\%$) | 1.234 | 1.24 | 1.246 | V |
| | | | | ULVH431-1 ($\pm 1\%$) | 1.228 | 1.24 | 1.252 | V |
| | | | | ULVH431-2 (+2%) | 1.252 | | 1.265 | V |
| | | | | ULVH431-3 (-2%) | 1.215 | | 1.228 | V |
| V_{REF} Deviation Over Full Temperature Range | $V_{REF(dev)}$ | $V_{KA}=V_{REF}$, $I_K=10\text{mA}$ (see Figure 1) | | | 11 | 31 | mV | |
| Ratio of V_{REF} Change to Cathode Voltage Change | $\frac{\Delta V_{REF}}{\Delta V_{KA}}$ | $I_K=10\text{mA}$ (see Figure 2), $V_{KA}=V_{REF}\sim 18\text{V}$ | | | -1.5 | -2.7 | mV/V | |
| Reference Terminal Current | I_{ref} | $I_K=10\text{mA}$, $R1=10\text{k}\Omega$, $R2=\text{Open}$ (see Figure 2) | | | 0.1 | 0.5 | μA | |
| I_{ref} Deviation Over Full Temperature Range | $I_{ref(dev)}$ | $I_K=10\text{mA}$, $R1=10\text{k}\Omega$, $R2=\text{Open}$ (see Figure 2) | | | 0.15 | 0.5 | μA | |
| Minimum Cathode Current for Regulation | $I_{K(min)}$ | $V_{KA}=V_{REF}$ (see Figure 1) | | | 60 | 100 | μA | |
| Off-State Cathode Current | $I_{K(off)}$ | $V_{REF}=0$, $V_{KA}=18\text{V}$ (see Figure 3) | | | 0.02 | 0.1 | μA | |
| Dynamic Impedance | $ Z_{KA} $ | $V_{KA}=V_{REF}$, $f\leq 1\text{kHz}$, $I_K=0.1\text{mA}\sim 50\text{mA}$ (see Figure 1) | | | 0.25 | 0.4 | Ω | |

■ EQUIVALENT SCHEMATIC

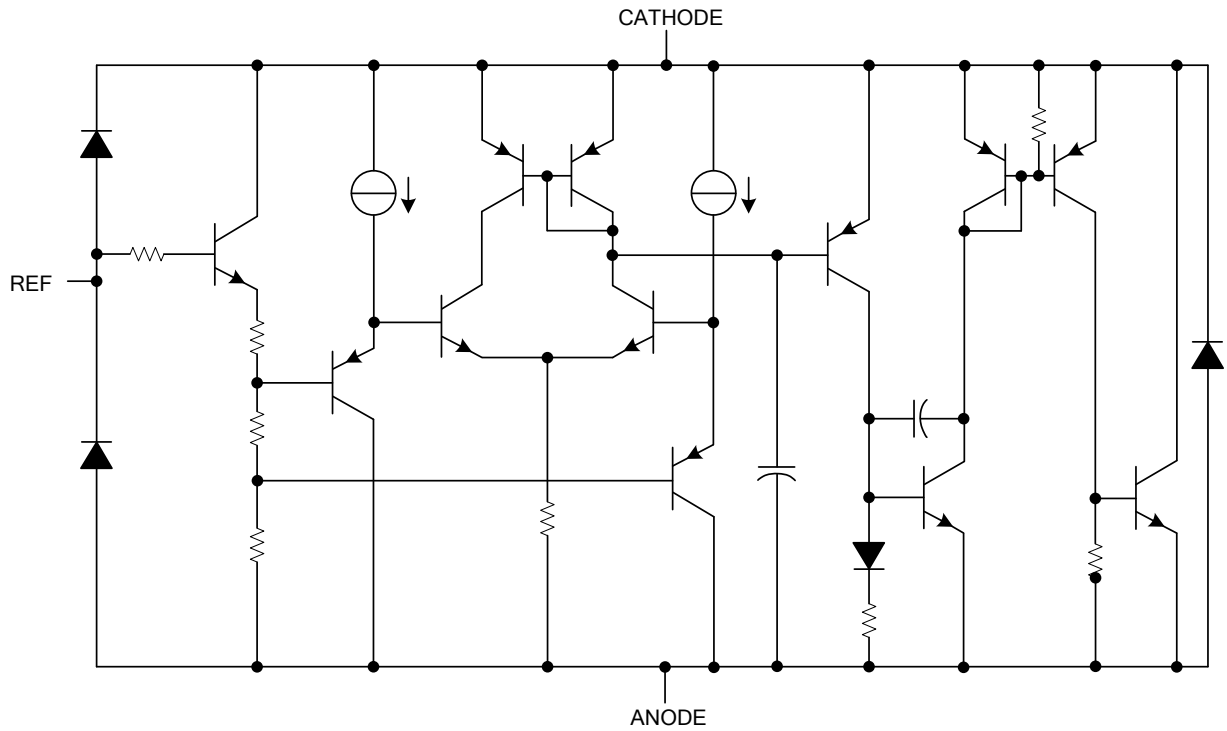

PARAMETER MEASUREMENT INFORMATION

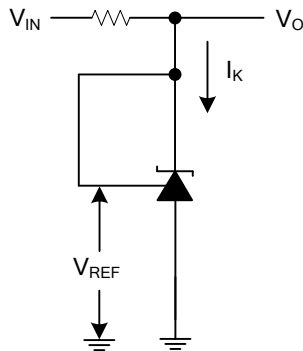

Figure 1. Test Circuit for $V_{KA} = V_{REF}$, $V_O = V_{KA} = V_{REF}$

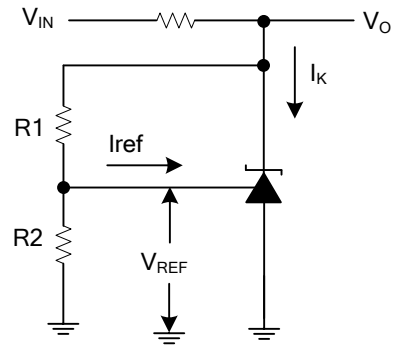

Figure 2. Test Circuit for $V_{KA} > V_{REF}$, $V_O = V_{KA} = V_{REF} \times (1 + R1/R2) + I_{ref} \times R1$

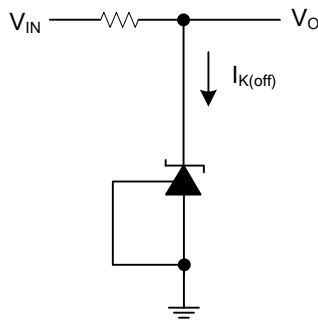

Figure 3. Test Circuit for $I_{K(off)}$

UTC assumes no responsibility for equipment failures that result from using products at values that exceed, even momentarily, rated values (such as maximum ratings, operating condition ranges, or other parameters) listed in products specifications of any and all UTC products described or contained herein. UTC products are not designed for use in life support appliances, devices or systems where malfunction of these products can be reasonably expected to result in personal injury. Reproduction in whole or in part is prohibited without the prior written consent of the copyright owner. UTC reserves the right to make changes to information published in this document, including without limitation specifications and product descriptions, at any time and without notice. This document supersedes and replaces all information supplied prior to the publication hereof.