



# 2SB1151

## PNP SILICON TRANSISTOR

LOW COLLECTOR  
SATURATION VOLTAGE  
LARGE CURRENT

■ FEATURES

- \*High Power Dissipation
- \*Complementary to 2SD1691

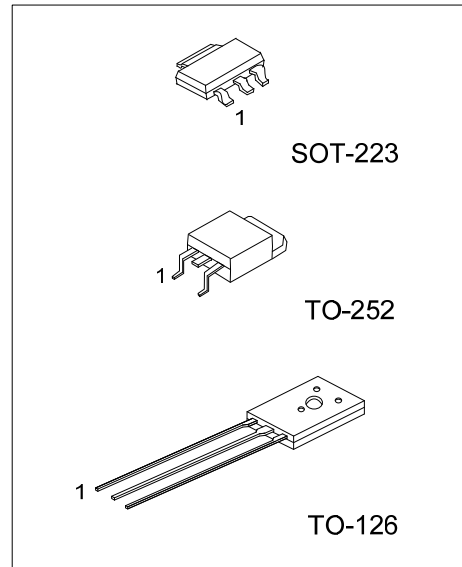

■ ORDERING INFORMATION

Ordering Number		Package	Pin Assignment			Packing
Lead Free	Halogen Free		1	2	3	
-	2SB1151G-x-AA3-R	SOT-223	E	C	B	Tape Reel
2SB1151L-x-T60-K	2SB1151G-x-T60-K	TO-126	E	C	B	Bulk
2SB1151L-x-TN3-R	2SB1151G-x-TN3-R	TO-252	B	C	E	Tape Reel

Note: Pin Assignment: E: Emitter C: Collector B: Base

<p>2SB1151G-x-AA3-R</p>	<p>(1) K: Bulk, R: Tape Reel                  (2) AA3: SOT-223, T60: TO-126, TN3: TO-252                  (3) x: refer to Classification of hFE2                  (4) G: Halogen Free and Lead Free, L: Lead Free</p>
-------------------------	---

■ MARKING

PACKAGE	MARKING
SOT-223	<p>1 → Data Code</p>
TO-126	<p>1 → Data Code                  L: Lead Free                  G: Halogen Free</p>
TO-252	<p>Lot Code → Data Code                  L: Lead Free                  G: Halogen Free</p>

■ ABSOLUTE MAXIMUM RATINGS (Ta=25°C)

PARAMETER		SYMBOL	RATINGS	UNIT
Collector-Base Voltage		$V_{CBO}$	-60	V
Collector-Emitter Voltage		$V_{CEO}$	-60	V
Emitter-Base Voltage		$V_{EBO}$	-7	V
Collector Current	DC	$I_C$	-5	A
	Pulse(Note 2)	$I_{CP}$	-8	A
Base Current		$I_B$	-1	A
Power Dissipation (Ta=25°C)	SOT-223	$P_D$	1	W
	TO-126		1.5	W
	TO-252		2	W
Junction Temperature		$T_J$	+150	°C
Storage Temperature		$T_{STG}$	-55 ~ +150	°C

Note 1. Absolute maximum ratings are those values beyond which the device could be permanently damaged.

Absolute maximum ratings are stress ratings only and functional device operation is not implied.

2.  $PW \leq 10ms$ , Duty Cycle  $\leq 50\%$

■ ELECTRICAL CHARACTERISTICS (Ta=25°C, unless otherwise specified)

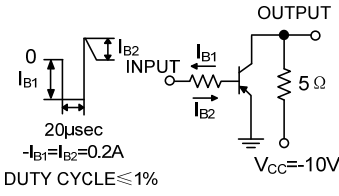
PARAMETER		SYMBOL	TEST CONDITIONS	MIN	TYP	MAX	UNIT
Collector-Base Voltage		$BV_{CBO}$	$I_C = -100\mu A, I_E = 0$	-60			V
Collector-Emitter Voltage		$BV_{CEO}$	$I_C = -1mA, I_B = 0$	-60			V
Emitter-Base Voltage		$BV_{EBO}$	$I_E = -100\mu A, I_C = 0$	-7			V
Collector Cut-off Current		$I_{CBO}$	$V_{CB} = -50V, I_E = 0$			-10	$\mu A$
Emitter Cut-off Current		$I_{EBO}$	$V_{EB} = -7V, I_C = 0$			-10	$\mu A$
Collector-Emitter Saturation Voltage		$V_{CE(SAT)}$	$I_C = -2A, I_B = -0.2A$		-0.14	-0.3	V
Base-Emitter Saturation Voltage		$V_{BE(SAT)}$	$I_C = -2A, I_B = -0.2A$		-0.9	-1.2	V
DC Current Gain		$h_{FE1}$	$V_{CE} = -1V, I_C = 0.1A$	60			
		$h_{FE2}$	$V_{CE} = -1V, I_C = -2A$	160		400	
		$h_{FE3}$	$V_{CE} = -2V, I_C = -5A$	50			
Switching Time	Turn On Time	$t_{ON}$			0.15	1	$\mu S$
	Storage Time	$t_{STG}$			0.78	2.5	$\mu S$
	Fall Time	$t_F$			0.18	1	$\mu S$

Pulse test :  $PW \leq 350 \mu S$ , Duty Cycle  $\leq 2\%$  Pulse

■ CLASSIFICATION OF  $h_{FE2}$

RANK	O	Y
RANGE	160 ~ 320	200 ~ 400

## TYPICAL CHARACTERISTICS

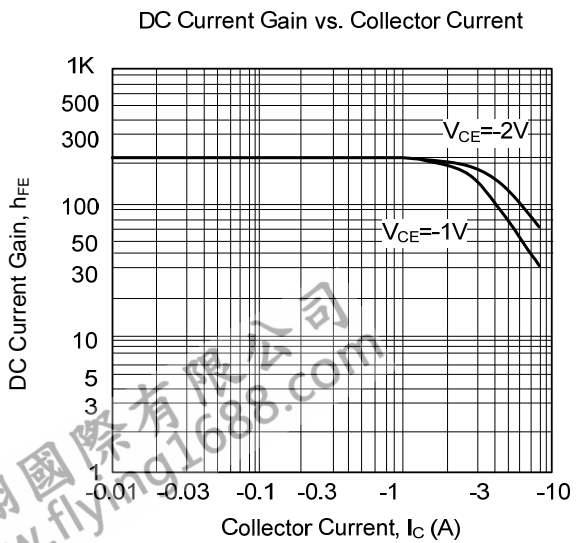
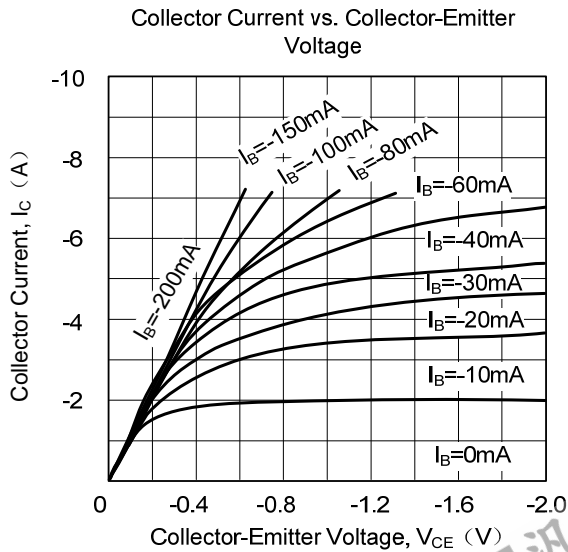
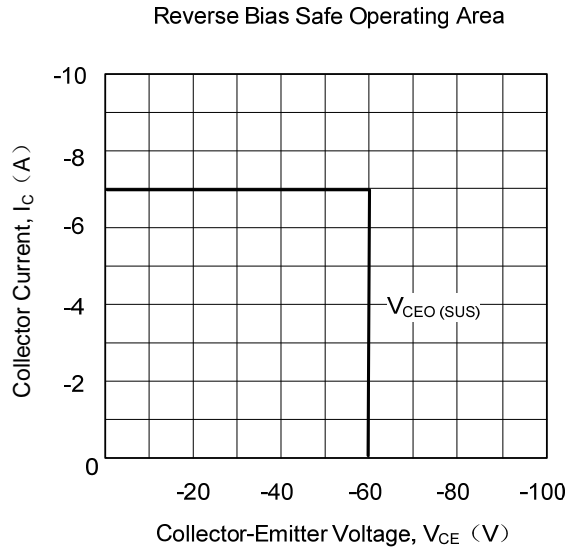
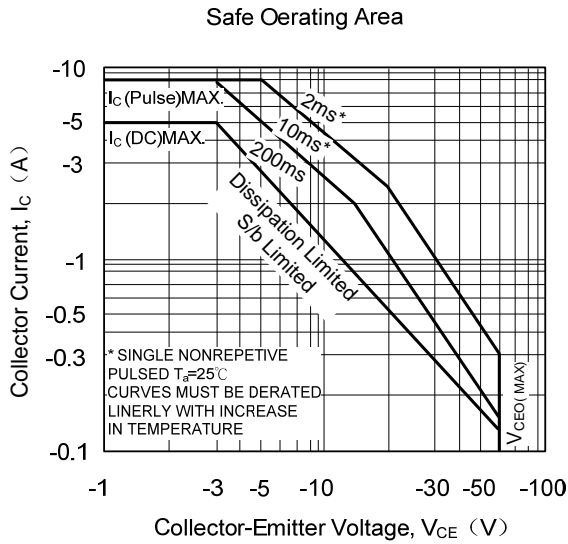
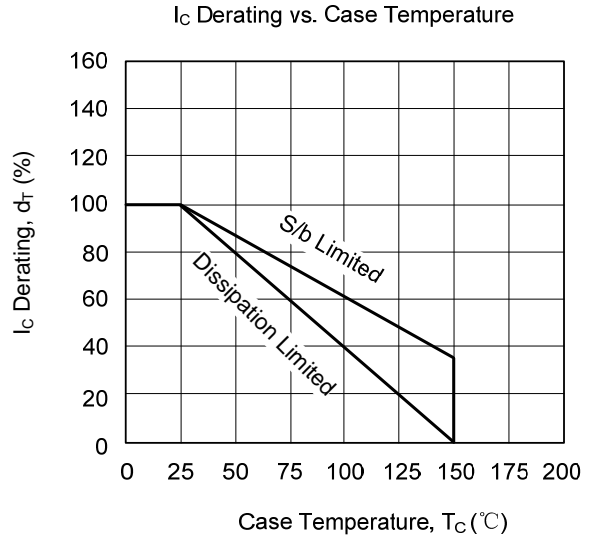
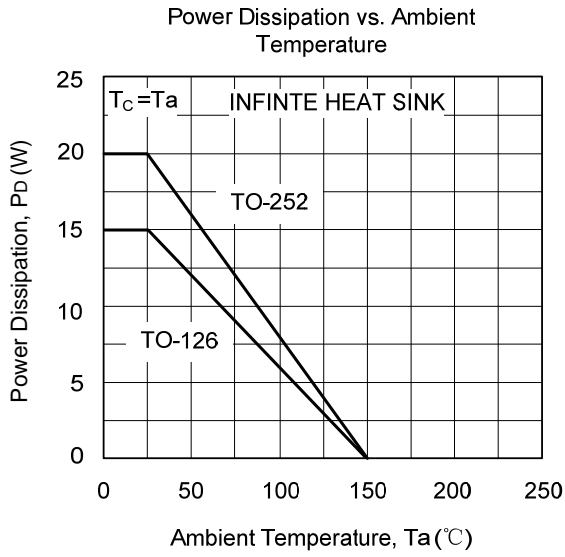

### ■ TYPICAL CHARACTERISTICS

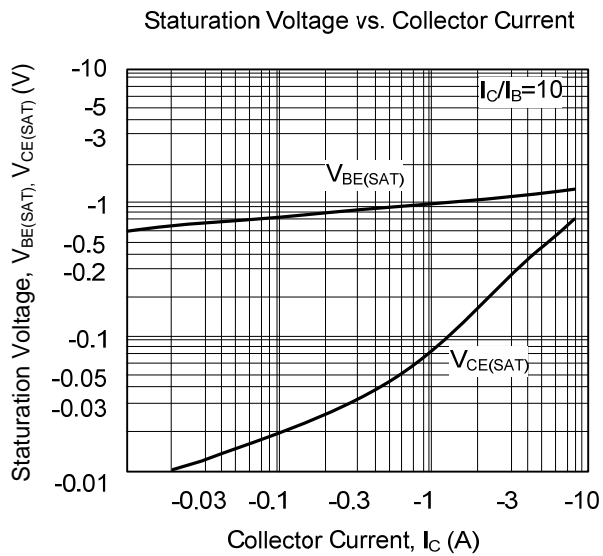

UTC assumes no responsibility for equipment failures that result from using products at values that exceed, even momentarily, rated values (such as maximum ratings, operating condition ranges, or other parameters) listed in products specifications of any and all UTC products described or contained herein. UTC products are not designed for use in life support appliances, devices or systems where malfunction of these products can be reasonably expected to result in personal injury. Reproduction in whole or in part is prohibited without the prior written consent of the copyright owner. The information presented in this document does not form part of any quotation or contract, is believed to be accurate and reliable and may be changed without notice.