

产品规格书

SPECIFICATION OF PRODUCT

日期 (Date): 2020-12-28

品名 (Part Name): 驻极体麦克风 (驻极方式: 背极式)

(Part Name): Electret Condenser Microphone (Electret Type:Back Electret)

贵公司品号 (Part Number):

敝公司品号 (P/N): B6027AP-SFN-B

承认印 (Stamp Of Reception)

FLYiNG 汎翊國際有限公司
www.flying1688.com

KINDS OF SPEC

1. CONSTRUCTION	-----	(3)
2. MEASUREMENT CIRCUIT	-----	(3)
3. SPECIFICATIONS	-----	(3)
4. ELECTRICAL	-----	(4)
5. FREQUENCY RESPONSE ALLOWANCE	-----	(4)
6. MEASUREMENT SYSTEM	-----	(5)
7. MECHANICAL	-----	(5)
8. RELIABILITY TEST	-----	(5)
	-----	(6)
9. LIST AND STRUCTURE OF MATERIALS	-----	(6)
	-----	(7)
10. PACKAGING	-----	(7)
	-----	(8)

PLEASE SEND US A COPY, IF YOU APPROVE

1、 CONSTRUCTION

Dimensions: $\phi 6.0 \times 2.7$ (Unit: mm)

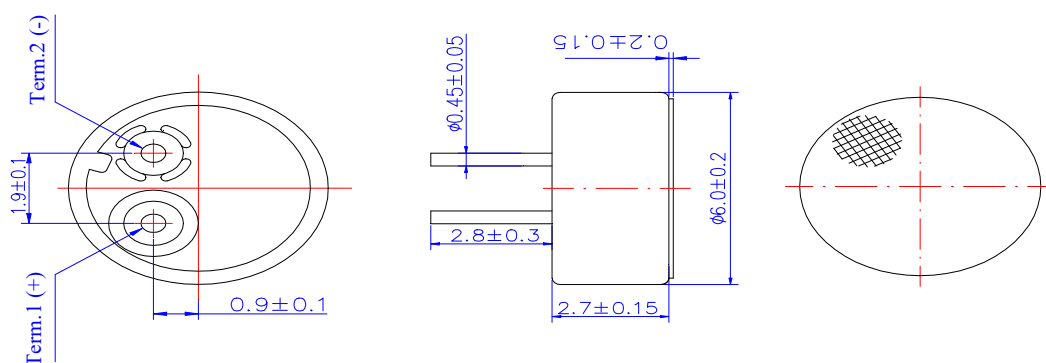

2、 MEASUREMENT CIRCUIT

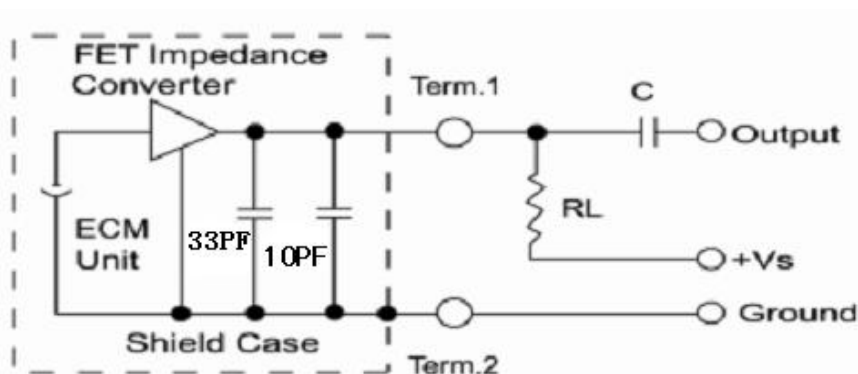

3、 SPECIFICATIONS

-40dB (0dB=1V/Pa) = **-60dB** (0dB=1V/ μ bar)

No.	Item	Standard
1	Sensitivity	-36 ± 3 dB (0dB=1V/Pa)
2	Output Impedance	≤ 2.2 K Ω
3	Directivity	Omnidirectional
4	Frequency Range	20-16,000Hz
5	Operation Voltage	DC 1.0V-10V
6	Standard Power Supply	DC3.0

No.	Item	Standard
7	Min Operation Voltage	1.5V
8	Current Consumption	$\leq 0.5\text{mA}$
9	Signal to Noise Ratio	$\geq 60\text{dB}$

4、 ELECTRICAL SPECIFICATIONS

Test Condition ($V_s = \text{DC}3.0\text{V}$, $R_L = 2.2\text{k}\Omega$ Temp= 20°C , Room Humidity= 65%)

Item	Test Condition	Minimum	Standard	Maximum	Unit
Sensitivity	f=1kHz, P=1Pa	-39	-36	-33	dB
Output impedance	f=1kHz, P=1Pa			2.2k	Ω
Directivity	f=1kHz, P=1Pa				
Current Consumption				0.3	mA
Signal to Noise Ratio	f=1kHz, P=1Pa A curve	60			dB
Decreasing Voltage Characteristic	f=1kHz, P=1Pa $V_s = 2\text{V}$ to 1.0V			-3	dB
Sound Pressure Level	f=1kHz	110			dB

5、 FREQUENCY RESPONSE ALLOWANCE RANGE

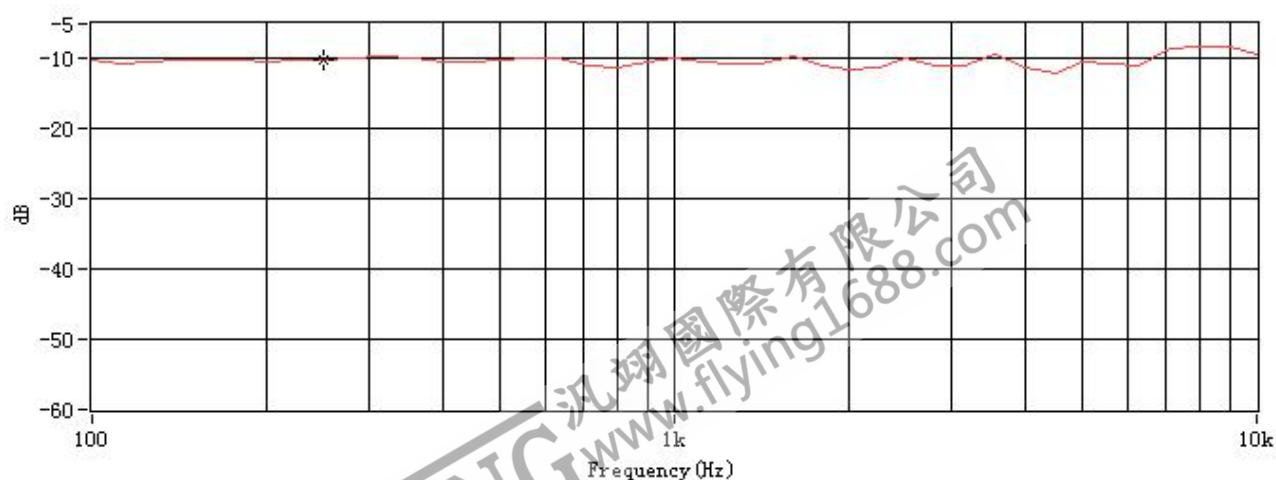

6、 MEASUREMENT SYSTEM

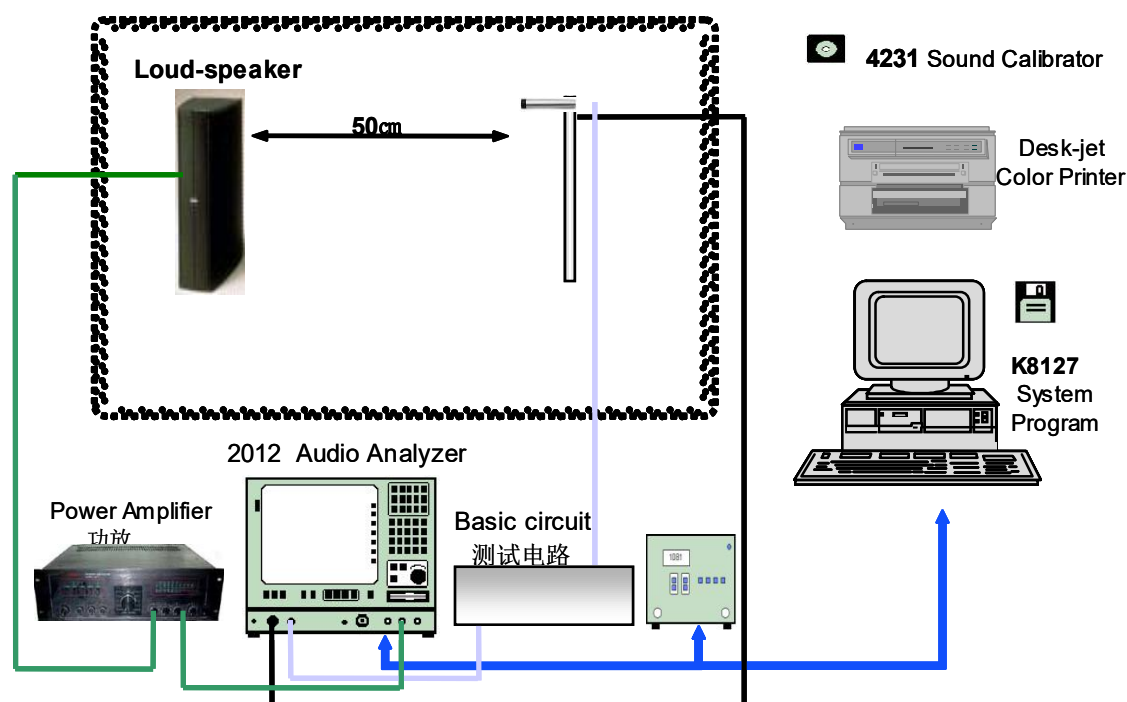

7、 MECHANICAL SPECIFICATION

Weight	Less than:0.46g	
Soldering Heat Shock	To be no interfere in operation after soldering heat shock, Temperature $260^{\circ}\text{C} \pm 5^{\circ}\text{C}$ for 3 ± 0.5 seconds.	
Terminal Mechanical Strength	To be no interfering in operation after pulled the terminal with 1kg strength for 1 minute.	
Absolute maximum Ratings	Operating Voltage	10V
	Storage temperature range	-25 – $+70^{\circ}\text{C}$
	Operating temperature range	-20 – $+60^{\circ}\text{C}$

8、 RELIABILITY TEST

Vibration Test	To be no interference in operation after vibration 10Hz to 50Hz for 1 minute full amplitude 1.52mm for 2 hour at three axes.
Drop Test	To be no interference in operation after dropped to concrete floor each one Time from 1 meter height at three directions in state of packing.

Temperature Test	<p>a) After exposure at 60°C for 200 hours, sensitivity to be within $\pm 3\text{dB}$ from initial sensitivity. (The measurement to be done after 2 hours of conditioning at 20°C)</p> <p>b) After exposure at -25°C for 200 hours, sensitivity to be within $\pm 3\text{dB}$ from initial sensitivity. (The measurement to be done after 2 hours of conditioning at 20°C)</p>
Humidity Test	<p>After exposure at 60°C $\pm 2^\circ\text{C}$ and 90 to 95 % relative humidity for 200 hours, sensitivity to be within $\pm 3\text{dB}$ from initial sensitivity. (The measurement to be done after 2 hours of conditioning at 20°C)</p>
Temperature Cycle Test	<p>After exposure at -25°C for 30 minutes, at 20°C for 10 minutes, at 70°C for 30 minutes, at 20°C for 10 minutes, 5 cycles, sensitivity to be within $\pm 3\text{dB}$ from initial sensitivity. (The measurement to be done after 2 hours of conditioning at 20°C)</p>

9、LIST AND STRUCTURE OF MATERIALS

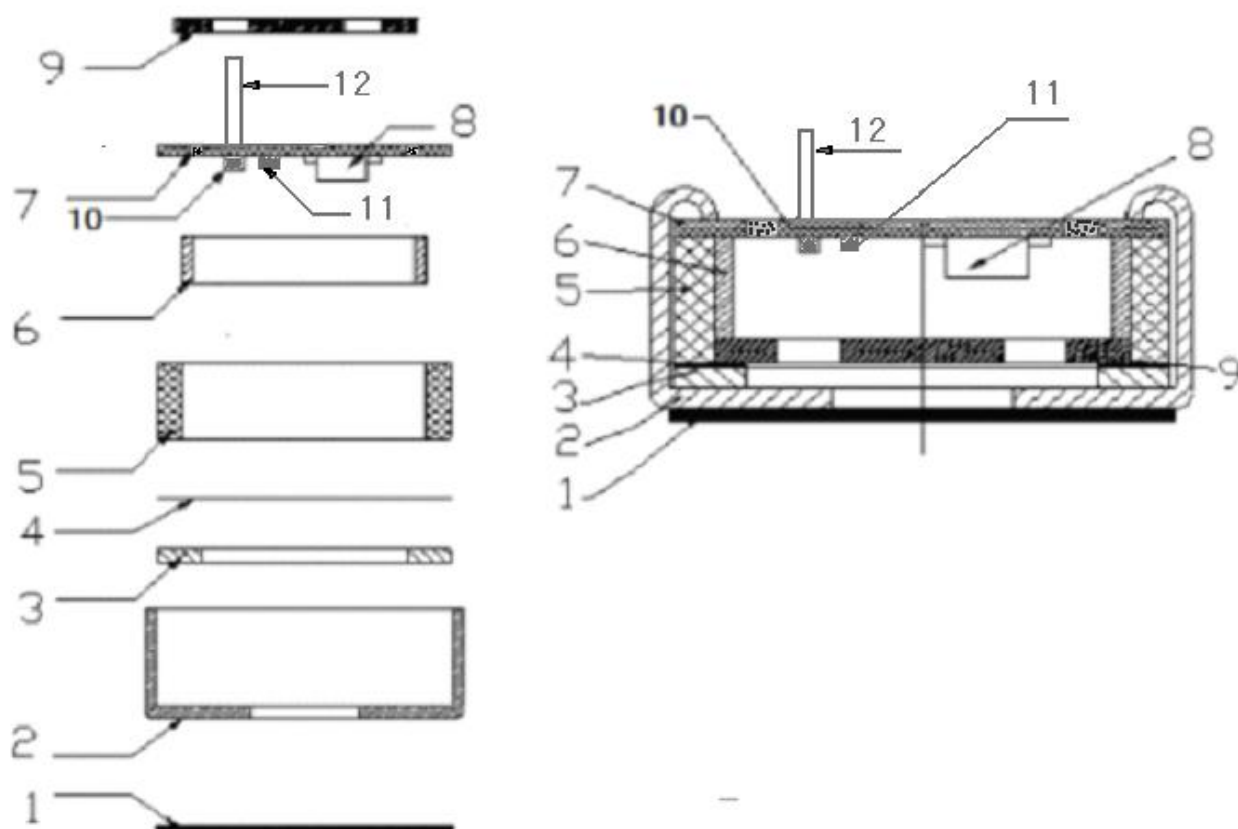

No. 序号	Part name 部件名称	Materials Type 材料型号	Qty 数量	Origin 产地	Manufacture 协力厂商
1	FELT	Fabric Cloth	1	China	Dongguan
2	Case	AL	1	China	Sanghai

3	Diaphragm	FEP	1	USA	Dupont
4	Spacer	Mylar	1	China	Weifang
5	Housing Chamber	Gather Formaldehyde	1	China	Longkou
6	Copper ring	Copper Tube	1	China	Longkou
7	P.C.B	FR-4	1	China	Suzhou
8	FET	RF1123KB	1	China	Korea
9	Back plate	Copper Blank	1	China	Weifang
10	CAPACITANCE	10PF	1	JAPAN	Senzhen
11	CAPACITANCE	33pF	1	JAPAN	Senzhen
12	JOIN PIN	BRASS (AU COATING)	2	China	Suzhou

10.PACKAGING

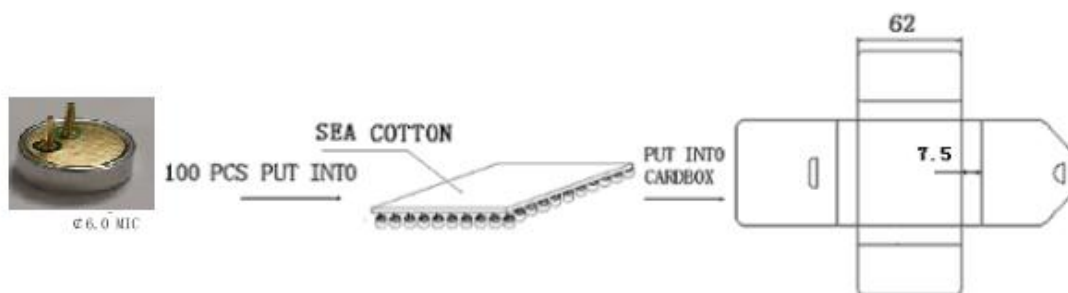

PUT INTO THE CARDBOX

