

General Description

The ELN2120 Series is a fixed frequency, constant current step-up DC/DC converter ideal for driving LEDs used in high-definition screen backlight LED driver etc. The highest output voltage is 24V, the input voltage of 3.6V can drive 3 series, 17 in parallel, a total of 51LED. The internal circuit integrated overvoltage protection circuit and temperature protection circuit, and the brightness of the leds can be controlled with a PWM signal. The internal circuit integrates a large pipes of 0.2 ohms.

Features

- Input voltage range 3.0V—6.0V
- Input voltage range up to 24V
- Oscillation frequency 1.2MHz±20%
- Efficiency 88%
- Control mode PWM control
- Stand-by Current ISTB=1.0uA(MAX)
- Load capacitor 10uF,ceramic

Applications

- HD screen LED driver

Package

- SOT-23-6L

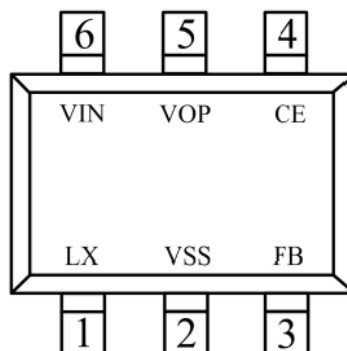

SOT-23-6L
(Top View)

Ordering Information

Item	Symbol	Function
①	B	Denotes Lx Over-voltage Limit: Yes Denotes Oscillation Frequency:1MHZ
②③④	010-149	Denotes FB Voltage e.g. ②=0 ③=2 ④=0 0.20V ②=1 ③=2 ④=3 1.23V
⑤	M	Denotes Package Type : SOT-23-6L
⑥	R	Embossed Tape :Standard Feed
	L	Embossed Tape :Reverse Feed

典型應用電路

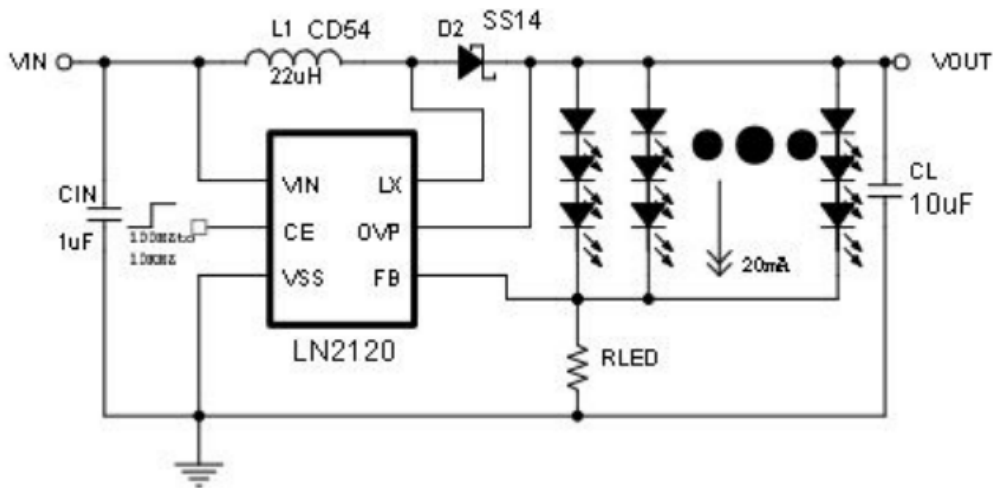

The application of single section lithium electricity power supply

Caution

The value of the resistance named RLED: $RLED = VFB / (ILED * n)$; VFB is the voltage of the FB pin; ILED is the current of LED and equal to 20mA usually. N is the number of LEDs in the circuit in parallel.

Functional Pin Description

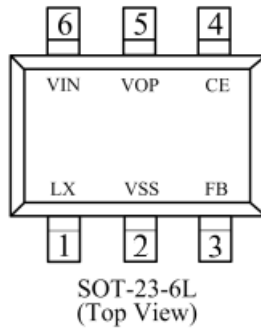

Pin Number	Pin Name	Function
1	LX	SWITCH
2	VSS	Ground
3	FB	Voltage Feedback
4	CE	Chip Enable
5	OVP	Over voltage protect
6	VIN	Power Input

Marking Rule

- SOT-23-6

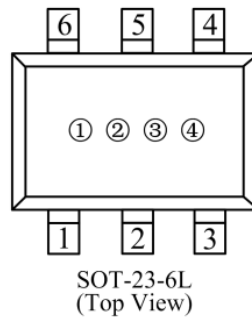

① Product Series

Symbol	Part Number
Y	ELN2120

② ③ Represents the voltage of FB pin and the type of regulator

Symbol	Vfb (mV)
H1	100mV
H0	200mV
H3	230mV
H5	250mV

④ Represents the assembly lot No.

0-9, A-Z; 0-9, A-Z mirror writing, repeated (G, I, J, O, Q, W exception)

Function Block Diagram

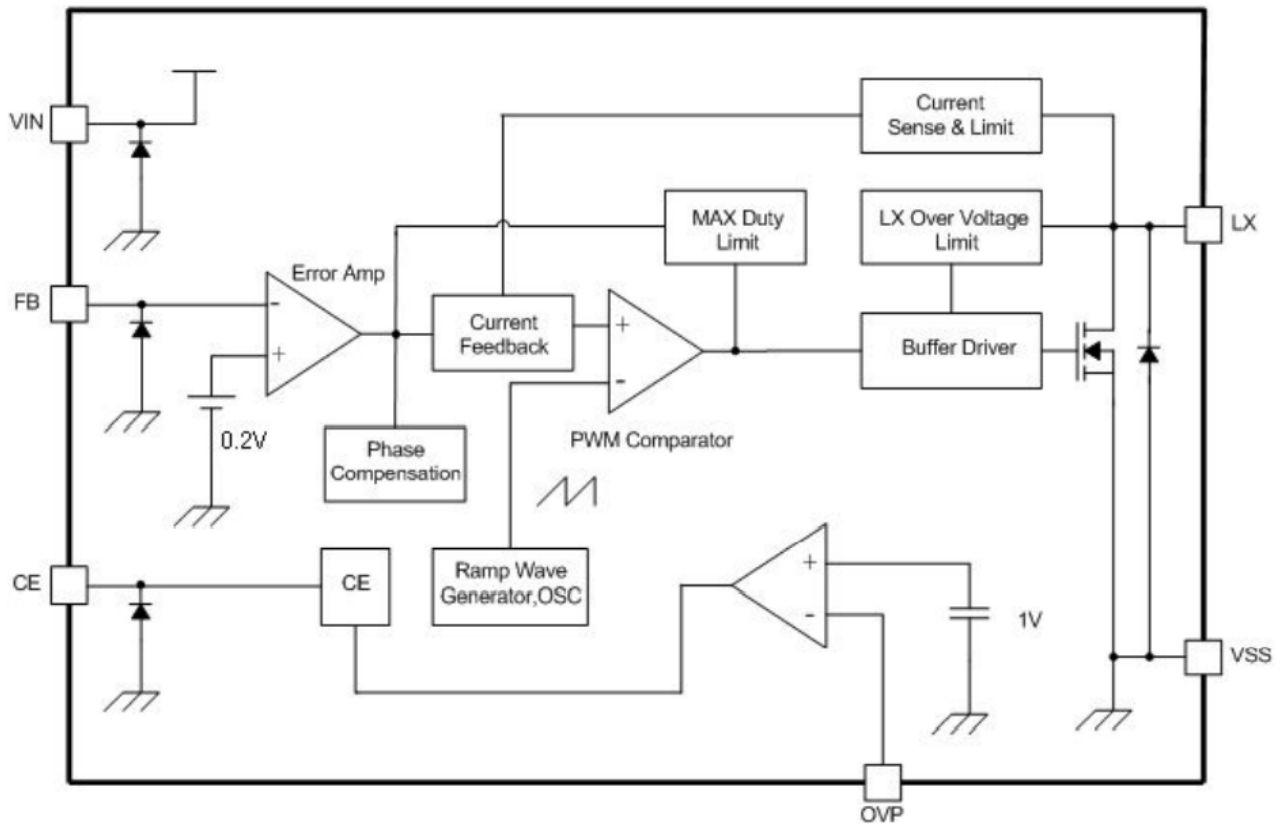

Absolute Maximum Ratings

項目	符號	絕對最大額定值	單位
VIN Pin Voltage	VIN	$V_{SS}-0.3 \sim V_{SS}+7$	V
OUT Pin Voltage	VOUT	$V_{SS}-0.3 \sim V_{SS}+26$	
LX Pin Voltage	VLX	$V_{SS}-0.3 \sim V_{SS}+26$	
FB Pin Voltage	Vfb	$V_{SS}-0.3 \sim V_{SS}+7$	V
CE Pin Voltage	Vce	$V_{SS}-0.3 \sim V_{SS}+7$	V
LX Pin Current	ILX	2500	mA
OVP Pin Voltage	Vovp	$V_{SS}-0.3 \sim V_{SS}+26$	
Power Dissipation	PD	SOT-23-6L	250
Operating Temperature range	Topr	-40~+85	mW
Storage Temperature range	Tstg	-55~+125	°C
ESD, Human body mode		2kv	
ESD, Machine mode		200v	

Caution: Absolute maximum rating refers to cannot exceed the rating in all conditions. One thousand more rating, can cause degradation products and other physical damage.

Electrical Characteristics (Ta = 25°C)

Item	Symbol	Condition	Min.	Typ.	Max.	Unit	Circuits
FB Control Voltage(*1)	VFB	-	0.19	0.20	0.21	V	1
Output Voltage range	VOUT	-	VIN	-	24		
Lx Operating Voltage range	VLX		-	-	24		
Operating Voltage range	VIN		3.0	-	6.0		
Stand-by Current	ISTB	VCE=0V、VLX=5V	—		1	μA	3
Supply Current 1	IDD1			800		μA	2
Supply Current 2	IDD2	VIN=VLX、VFB=0.4V	—	250			3
Oscillation Frequency	FOSC		1.0	1.2	1.4	MHz	2
Maximum Duty Cycle	MAXDTY	VCONT=0.4V	86	92	98	%	2
Efficiency	EFFI	VIN=3.6V;RLED=20Ω	—	88	—	%	1
Current Limit	ILIM	VIN=3.6		2500		mA	4
OVP Overvoltage Limit	OVPOVL			24		V	2
LX On Resistance		VIN=3.6V、VLX=0.4V		0.2		Ω	2
LX Leak Current	ILXL			0	1	μA	3
CE 'H' Voltage	VCEH		1			V	2
CE 'L' Voltage	VCEL				0.6	V	2
CE 'H' Current	ICEH	同 IDD2			0.1	μA	3
CE 'L' Current	ICEL	同 ISTB			-0.1	μA	3
FB 'H' Current	ICEH	同 IDD2			0.1	μA	3
FB 'L' Current	ICEL	同 ISTB			-0.1	μA	3

(*1) Vfbt may take between 0.01V-1.49V certain value, now a major center value 0.01V, 0.2V,0.23V,0.25V

Test Circuits

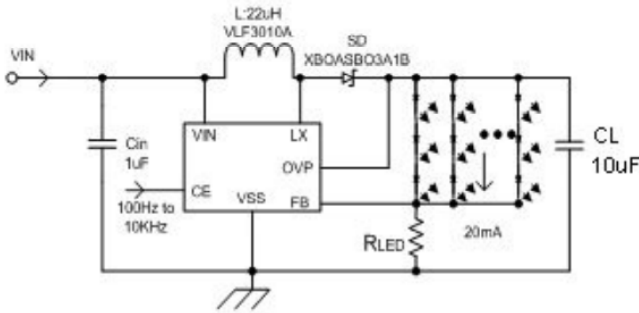

Circuit 1

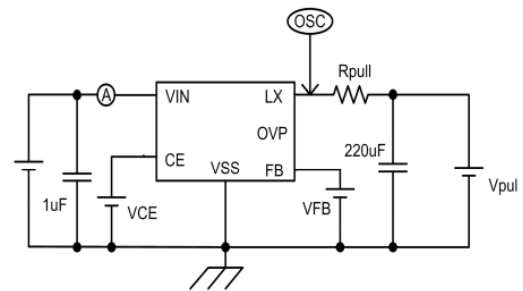

Circuit 2

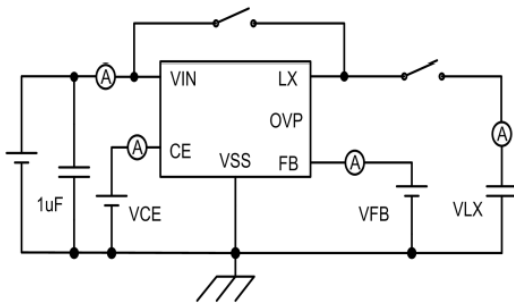

Circuit 3

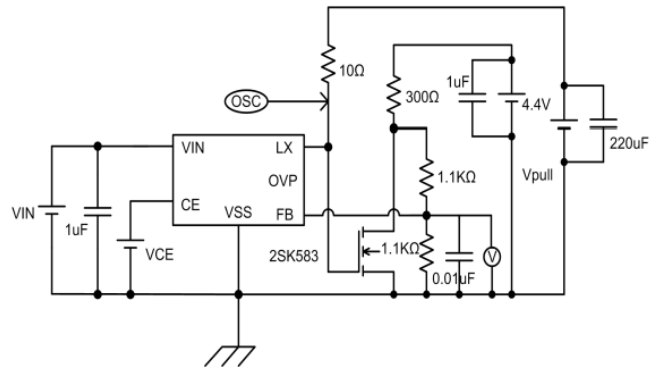

Circuit 4

Caution: The value of the resistance named RLED: $R_{LED} = V_{FB} / (I_{LED} * n)$; VFB is the voltage of the FB pin; ILED is the current of LED and equal to 20mA usually. N is the number of leds in the circuit in parallel.

Typical Performance Characteristics

1、FB dimming characteristic curve

VIN=3.6、LED: 3*17;

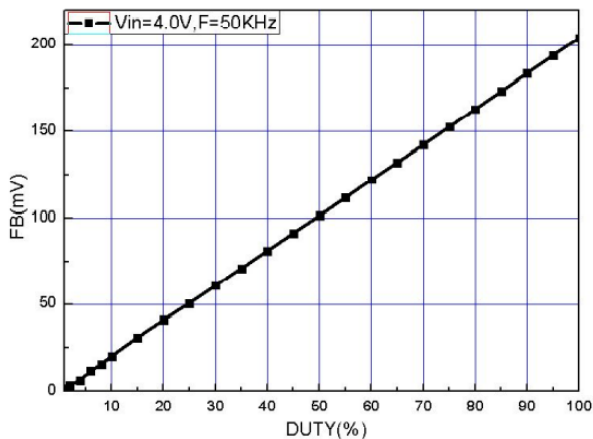

2、VFB VS Temperature

VIN= 4.0V, LED=3*7;

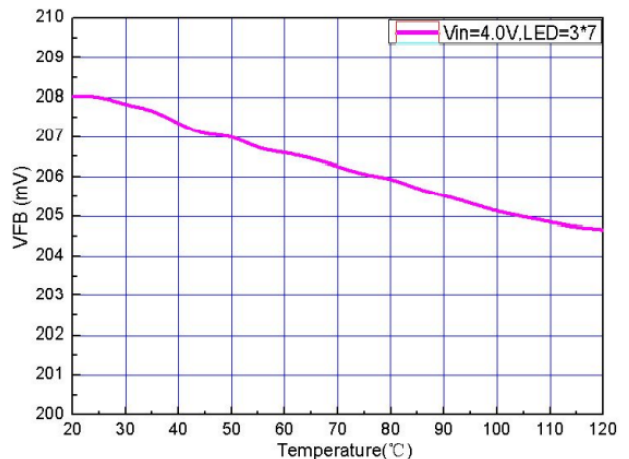

Package Information

- SOT-23-6L

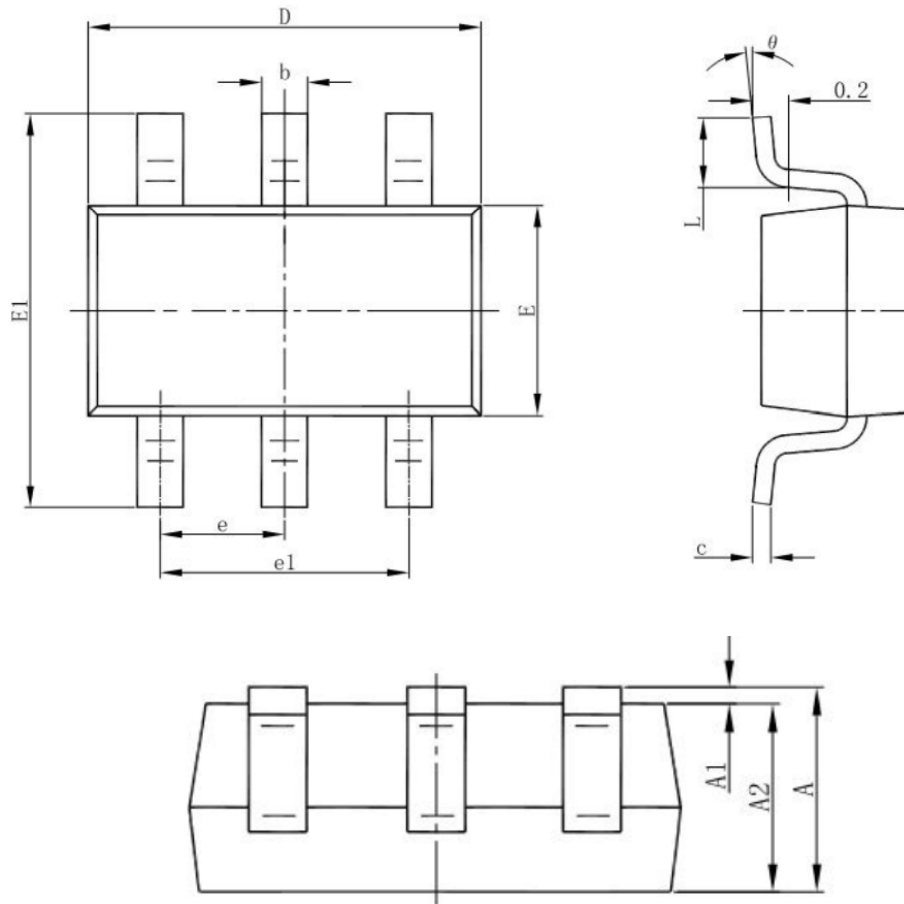

Symbol	Dimensions In Millimeters		Dimensions In Inches	
	Min	Max	Min	Max
A	1.050	1.250	0.041	0.049
A1	0.000	0.100	0.000	0.004
A2	1.050	1.150	0.041	0.045
b	0.300	0.500	0.012	0.020
c	0.100	0.200	0.004	0.008
D	2.820	3.020	0.111	0.119
E	1.500	1.700	0.059	0.067
E1	2.650	2.950	0.104	0.116
e	0.950(BSC)		0.037(BSC)	
e1	1.800	2.000	0.071	0.079
L	0.300	0.600	0.012	0.024
θ	0°	8°	0°	8°