

A

B

C

D

A

B

C

D

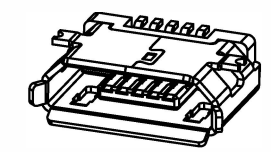
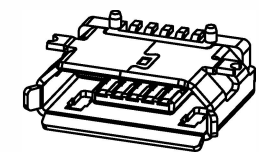
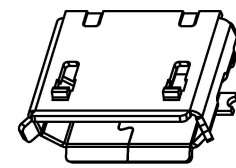
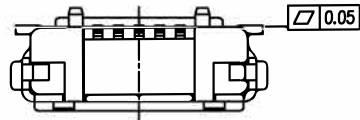

With Embossing

Without Embossing

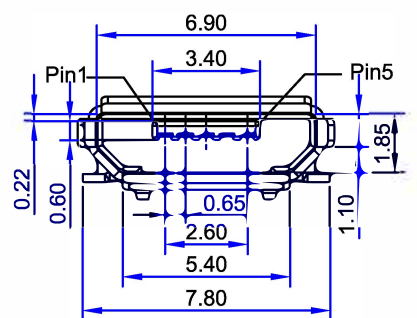
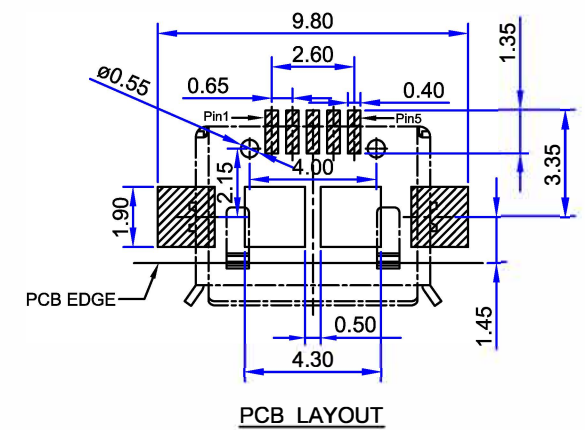
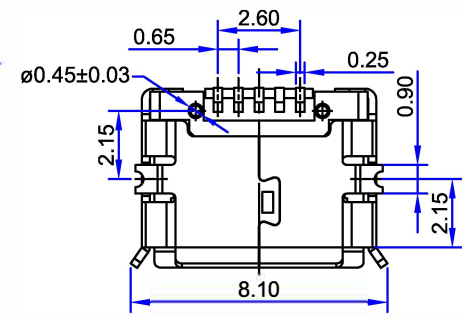
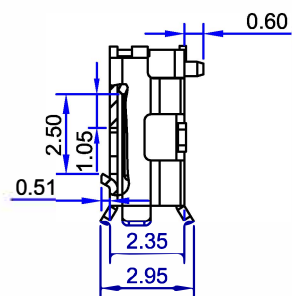
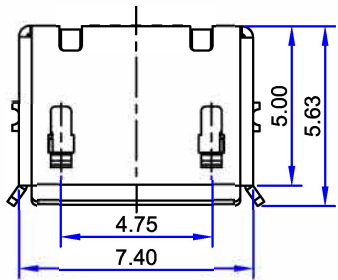
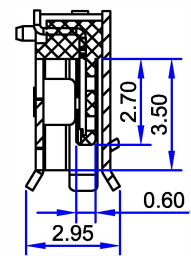

BUS-MI5BF(M)L-BC1-RP-(N)-L

Micro USB 5F SMD Type :With Embossing
:Without Embossing
 Housing Material: L:LCP Package Type: RP:Reel Package
 Housing Color: B:Black Contact Plating: 1:Gold flash.
 Shell Material: C:Brass of Ni Plated 铜壳镀镍
 CI:Brass of Sn Plated 铜壳镀锡

Note:

- 1.Material:
 - 1.1 Housing: High temperature thermoplastic with g.f,UL94v-0
 - 1.2 Contact: copper alloy,t=0.20mm
 - 1.3 Shell: copper alloy,t=0.25mm
- 2.Specification:
 - 2.1 Current rating: 1 A Max.
 - 2.2 Dielectric withstanding voltage: 100 V(ac) for 1 min.
 - 2.3 Contact resistance: 50 mΩ Max.
 - 2.4 Insulation resistance: 100 MΩ Min.
 - 2.5 Total mating force: 3.57 Kgf Max.
 - 2.6 Total unmating force: 1.0 Kgf Min.0.81~2.05 Kgf Min.after 10000 insertion/extraction cycles
 - 2.7 Temperature range: -30°C~80°C

General Tolerance	
.X	±0.38
.XX	±0.25
.XX	±0.13
X°	±3°
.X°	±1°

	单位	比例	日期	核准	审核	设计绘图	料号	BUS-MI5BFML-BC1-RP-(N)-L	页数	1 / 1
	mm	5:1	2012-07-06	Jason	Enui	Ada	品名	Micro USB Connectors	版本	B
汎翊國際有限公司							图号	BUS-MI5BFML-BC1-RP-(N)-L		