



REV.	ECN NO.	REVISED	DATE

NOTE:

1.MATERIAL:

- a.HOUSING:LCP UL94V-0
- b.CONTACT:PHOSPHOR BRONZE
(SURFACE PLATING:Sn100u"-120u")
SEE ORDERING INFORMATION

2.ELECTRIC:

- a.CONTACT RESISTANCE: 30 MILLIOHMS MAX
- b.INSULATION RESISTANCE: 1000 MEGA OHMS MIN
- c.DIELECTNIC VOLTAGE: 500V AC ONE SEC LEVEL
- d.OPERATING TEMPERATURE: -25°C~ +85°C

ORDERING INFORMATION

F-06-A***004

電池盒系列

F-06系列

DIP 90° TYPE

PLATING:
A-Au1U"
J-Ni100U"~120U"
K-SN100U"~120U"

MATERIAL:
1A-PBT BLACK
1B-PA66 BLACK
2A-PPA BROWN
2B-PPA BLACK
3A-PPS BROWN
3B-PPS BLACK
4A-LCP WHITE
4B-LCP BLACK

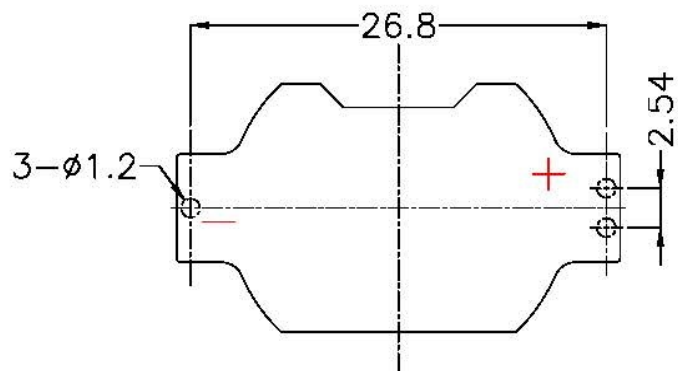
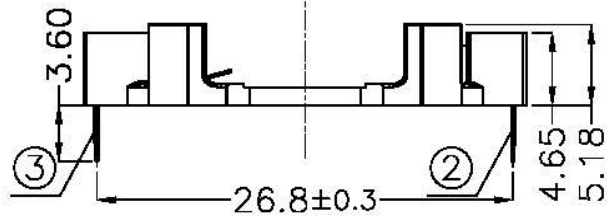
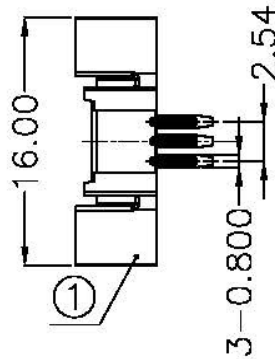
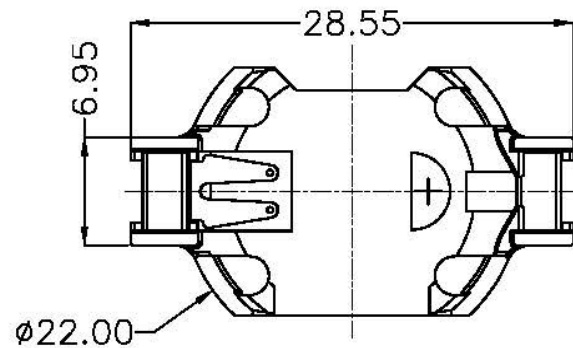

PCB Layout Diagram
Top View



3	TERMINAL(-)	1	PHOSPHOR BRONZE, T=0.20mm	Sn Plating
2	TERMINAL(+)	1	PHOSPHOR BRONZE, T=0.20mm	Sn Plating
1	HOUSING	1	LCP	WHITE
NO.	PART NAME	Q'TY	MATERIAL	PLATING & COLOR

UNLESS OTHERWISE SPECIFIED TOLERANCES		FLYING 汎翊國際有限公司 INTERNATIONAL			
DECIMALS: X : ±0.30 X.X : ±0.25 X.XX : ±0.20 X.XXX : ±0.10	ANGLES: X : ±1' X.X : ±0.5'	DSND	YangFeng	DATE	2017-07-11
		CHKD	ZhouRuicai	DATE	2017-07-11
		APVD	XueShunyang	DATE	2017-07-11
WEIGHT: 1.02g		SCALE: 2:1	SIZE: A4	VIEW:	TITLE: F-2032-6-2 Sn DIP
SHEET 1 OF 1		UNIT: mm	REV.: A/0	OBJECT: MY	PART NO.: F-06-A4AK004
					DRAW NO.:MY-CP-0015