

---

**Low-Dropout, Constant-Current  
White LED with Dimming Control and Low Voltage Detect**

---

**FEATURES**

- Low Voltage Detection and Indication: Detect Voltage Level Options by External Resistor
- Up to 700mA LED Bias Current
- External Resistor to set Output Current
- Simple LED Dimming Control
- Build-in Morse Code S.O.S Signal and Single Flash Loop Flicker Function
- Low Dropout Voltage
- Low 0.05uA Shutdown Current
- 2.7V to 6V Supply Voltage Range
- TO-252, SOP-8 and SOT-23 lead-free Package
- ESD Human Body Mode Over 5KV
- Thermal Protection 160 °C

**APPLICATIONS**

- Handheld Electronics
- Flash Light
- Lighting

**GENERAL DESCRIPTION**

T6340A provides the low-dropout bias supply and the high performance alternative solution for the white LEDs application. The build-in Low Voltage Detection and Indication function can provide the internal LED dimming. Morse Code S.O.S Signal and Single Flash Loop Flicker Function are supported with the significantly lower dropout voltage. The T6340A is available in TO-252, SOP-8 and SOT-23 lead-free package.

**PART NUMBER EXAMPLES**

PART NO.	PACKAGE
T6340AWG	TO-252(A)
T6340BWG	TO-252(B)
T6340AD	SOP-8
T6340AX	SOT-23-6

**PIN ARRANGEMENT(Top view)**

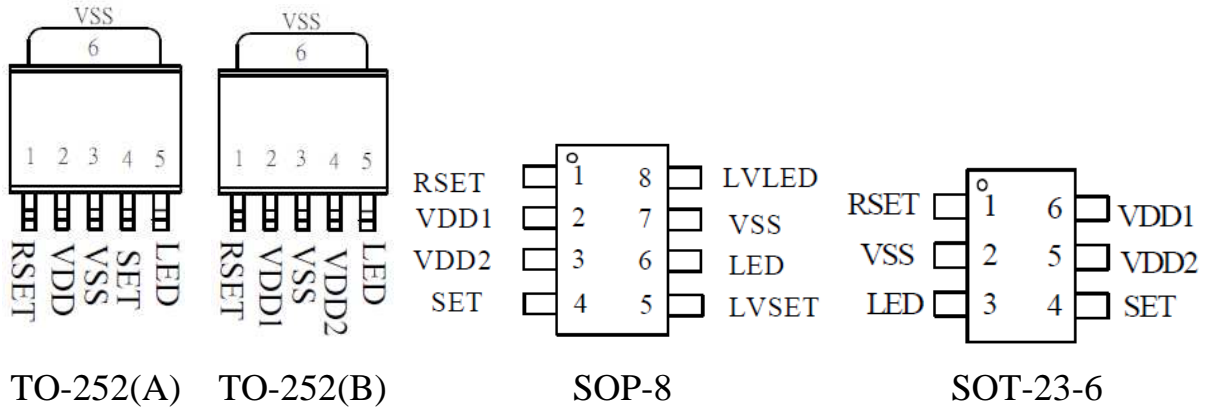

**PIN DESCRIPTION**

SYMBOL	TO-252(A)	TO-252(B)	SOP-8	SOT-23	DESCRIPTION
RSET	1	1	1	1	Connect to an external resistor to set output current.
VSS	3	3	7	2	Ground
VDD1/2	2	2/4	2,3	5,6	Power supply
LED	5	5	6	3	LED Cathode Connection.
SET	4	-	4	4	Control ON/OFF or dimming and flicker mode
LVLED	-	-	8	-	Low Voltage Detection Indicator LED Cathode Connection.
LVSET	-	-	5	-	Connect to an external resistor to set “low voltage detection” level.

**ABSOLUTE MAXIMUM RATINGS**

Parameter	Symbol	Value	Unit
Voltage on any pin relative to GND	V <sub>IN</sub>	-0.3 to 7	V
Operating Temperature Rang	T <sub>A</sub>	-40 to +85	°C
Maximum Soldering Temperature (at leads, 10 sec)	T <sub>LEAD</sub>	300	°C
Storage Temperature Rang	T <sub>S</sub>	-65 to +150	°C
Continuous Power Dissipation ( T <sub>A</sub> = +70°C )	SOT-23	350	mW
	SOP-8	800	
	TO-252	1600	

**Electrical Characteristics**

 (Typical values are at T<sub>A</sub> =25°C)

Symbol	Description	Conditions	Min.	Typ.	Max	Unit
V <sub>DD</sub>	Operating voltage range	power supply input	2.7		6	V
V <sub>RSET</sub>	RSET bias voltage	I <sub>SET</sub> =400uA, no loading		0.5		V
I <sub>SET</sub>	SET input current range			100		uA
I <sub>LED</sub>	Maximum LED sink current	V <sub>DD</sub> = 4.5V V <sub>LED</sub> =3.5V		700		mA
I <sub>LVLED</sub>	Low voltage detection output	Options : 2mA,4mA,6mA, 8mA		Options		
V <sub>LVLED</sub>	Low voltage detection level			10		%
I <sub>LSD</sub>	LED leakage current in shutdown	V <sub>LED</sub> = 3.3V, V <sub>DD</sub> =0V, T <sub>A</sub> =+25°C		0.02	1	uA
t <sub>SH</sub>	SET pin Signal pulse width		30			ms
V <sub>IH</sub>	Input high voltage	V <sub>SET</sub> >V <sub>IH</sub> for enable, V <sub>DD</sub> =5V	2.0			V
V <sub>IL</sub>	Input low voltage	V <sub>SET</sub> <V <sub>IL</sub> for disable, V <sub>DD</sub> =5V			0.8	V
T <sub>TP</sub>	Thermal Protect			160		°C

**Functional Description**

The T6340A provides constant current bias supply for white LED applications. Build in Morse Code S.O.S Signal and Single Flash Loop Flicker Function can provide more advantages over than using ballast resistors to the LED dimming: lower bias variation and significantly lower dropout voltage. The T6340A also provides the Low Voltage Detection and Indication function to reach the best efficiency.

**Output Current Setting**

RSET pin controls the LED bias current. I<sub>max</sub> Current flowing into LED is 250 times greater than the current flowing into RSET. User can set the output current as the following formula:  
each channel:

$$I_{LED} = 250 (0.5V / RSET )$$

**Power on the Function Options**

The T6340A can choose the initial states when powering on. The flexibility design allows starting the steps with all function in loop or choosing only the certain functions.

**Dimming Function Option**

Dimming options are to set the output current 1/2, 1/3, 1/4, 1/5 and 1/6. This function can be the multiple choices as needed.

**Flicker Function Option**

Flicker frequency options:  
1Hz / 2 Hz /4 Hz / 6 Hz

Flicker duty options:

1/2, 1/4, 1/8, 1/16

For example:

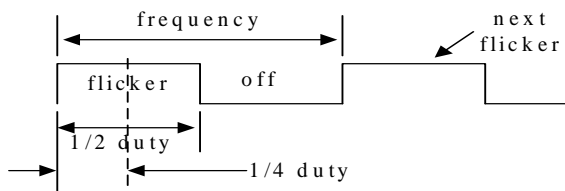

**S.O.S frequency options:**

The time length of S.O.S and the interval time can be followed as the below table:

	Option1	Option2	Option3	Option4
time length of S.O.S	17.4sec	8.6sec	4.28sec	2.86sec

**Low Voltage Detection**

The T6340A builds in Low Voltage Detection and Indication function. If VIN voltage drops to the default value of Detection Voltage, LVLED pin will turn on to lighten the low voltage indicator.

Detected options :

- Voltage level detection options are subject to the External Resistor, user can set the voltage level as following formula:  
 $LV=55\mu A * RSET$
- LVLED output current options are: 2,4, 6, 8mA

**Function of SET**

When keeping at high level, SET pin will active as the requested function in order, like LED ON / OFF, dimming and flicker mode.

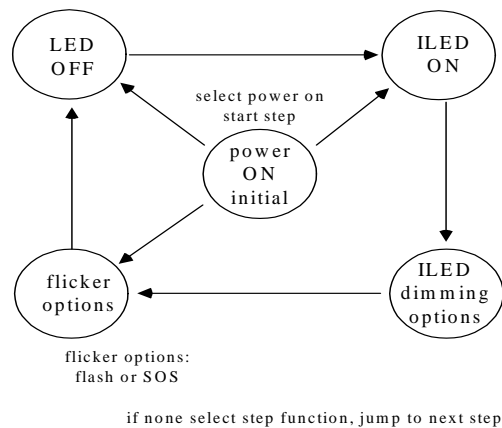

**Applications Information**

T6340A is a very Low-Cost and High-Efficiency Solution. A battery (single Li+ or three NiMH cells) powers the LEDs directly. This is the least expensive and most efficient architecture. Due to the high forward voltage of white LEDs, the LED dimming may do slightly at the end of battery life. The current regulating architecture and low dropout of the T6340A greatly minimize this effect compared to using simple ballast resistors.

**TYPICAL APPLICATION CIRCUITS**

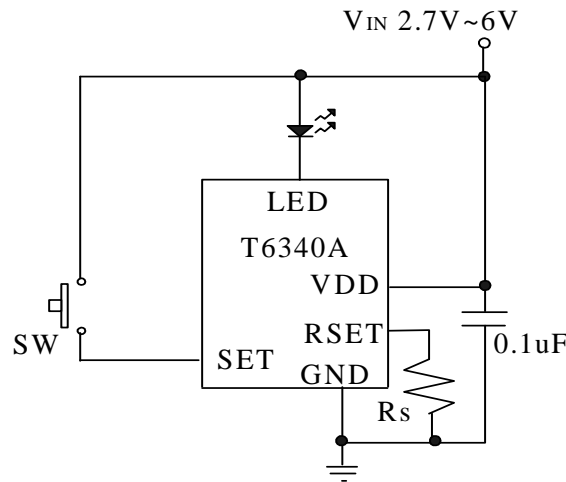

Very low-cost, high-efficiency solution for TO-252 and SOT-23 package

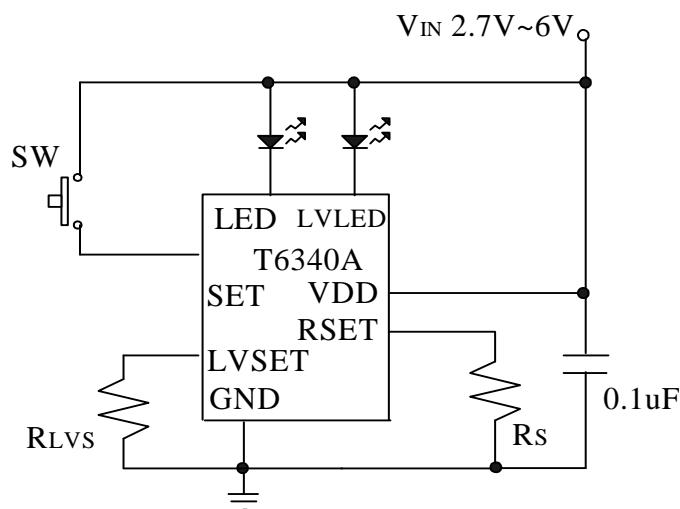

Very low-cost, high-efficiency solution for SOP-8 package

**PACKAGE DIMENSIONS**

**5-LEAD TO-252**

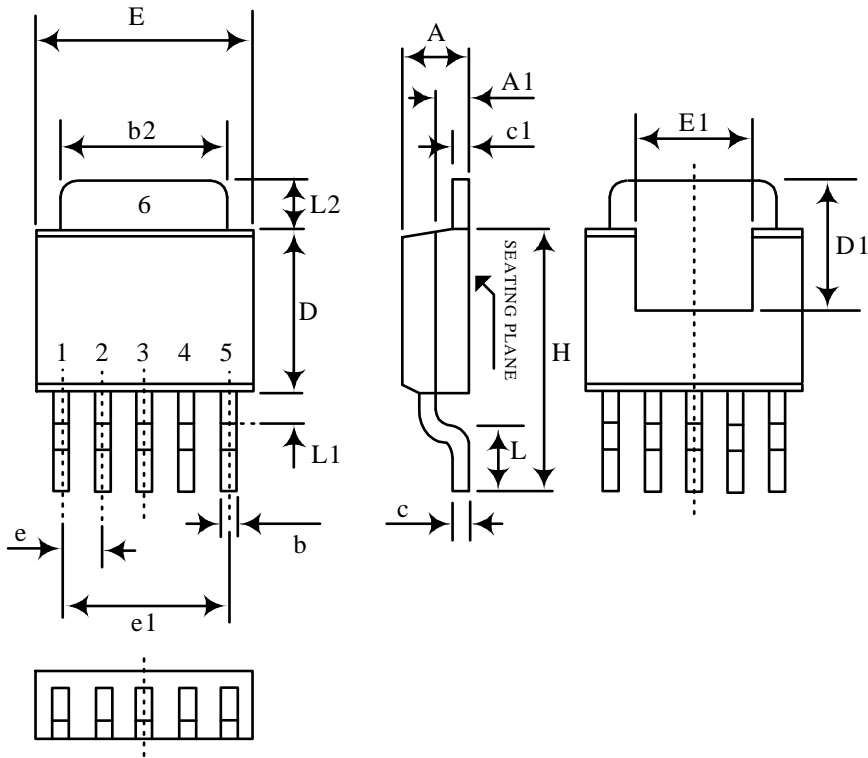

Symbol	Dimension in inch		Dimension in mm	
	Min.	Max.	Min.	Max.
A	0.087	0.094	2.20	2.40
A1	0.040	0.050	1.00	1.27
b	0.016	0.24	0.40	0.60
b2	0.205	0.213	5.20	5.40
c	0.017	0.023	0.43	0.58
c1	0.017	0.023	0.43	0.58
D	0.213	0.224	5.40	5.70
D1	0.150 (REF.)		3.80 (REF.)	
E	0.250	0.262	6.35	6.65
E1	0.150 (REF.)		3.80 (REF.)	
e	0.050 (TYP.)		1.27 (TYP.)	
e1	0.200 (TYP.)		5.08 (TYP.)	
H	0.313	0.338	7.94	8.6
L	0.055	0.070	1.40	1.78
L1	0.043	0.047	1.09	1.19
L2	0.050	0.060	1.30	1.50

**PACKAGE DIMENSIONS**  
**8-LEAD SOP**

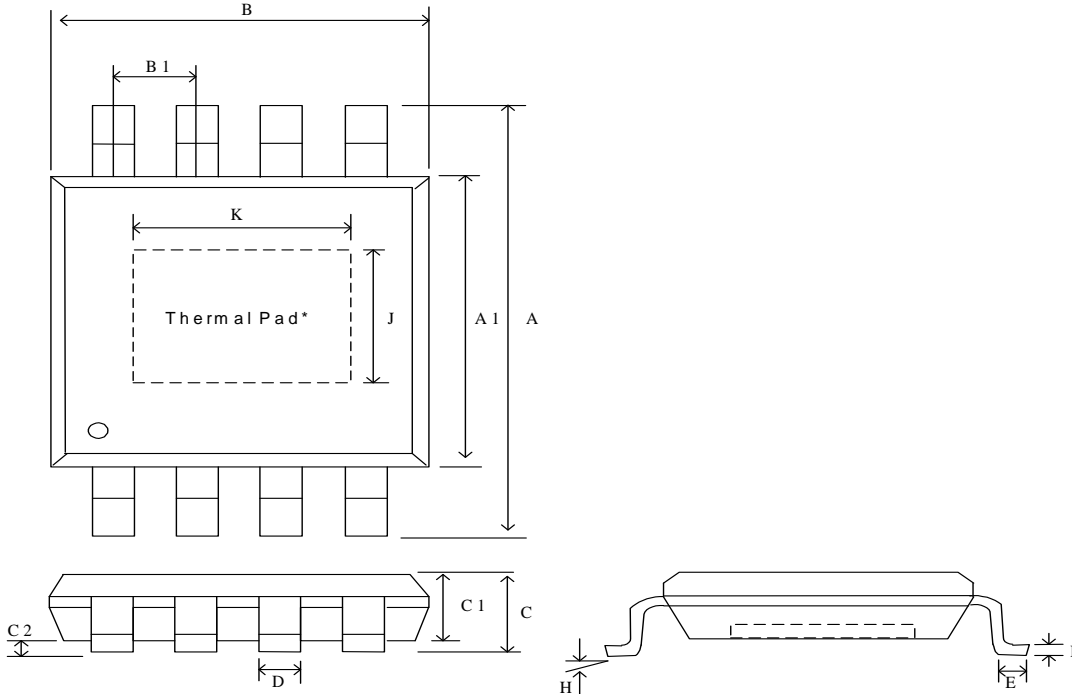

Symbol	Dimension in mm			Dimension in inch		
	Min.	Typ.	Max.	Min.	Typ.	Max.
A	5.70	6.00	6.30	0.224	0.236	0.248
A1	3.75	3.95	4.10	0.148	0.156	0.164
B	-	-	5.13	-	-	0.202
B1	-	1.27	-	-	0.050	-
C	-	-	1.80	-	-	0.071
C1	1.35	1.55	1.75	0.052	0.061	0.069
C2	0.10	-	0.25	0.001	-	0.004
D	0.31	0.41	0.51	0.012	0.016	0.020
E	0.30	0.50	0.70	0.012	0.020	0.028
F	0.10	0.15	0.25	0.004	0.006	0.010
J		2.23 REF			0.088 REF	
K		2.97 REF			0.117 REF	
H	0~8°			0~8°		

**\*Note :**

The thermal pad on the IC's bottom has to be mounted on the copper foil.

To eliminate the noise influence, the thermal pad is suggested to be connected to GND on PCB.

In addition, desired thermal conductivity will be improved, if a heat-conducting copper foil on PCB is soldered with thermal pad. The thermal pad enhances the power dissipation. As a result, a large amount of current can be sunk safely in one package.

**PACKAGE DIMENSIONS**  
**SOT23-6**

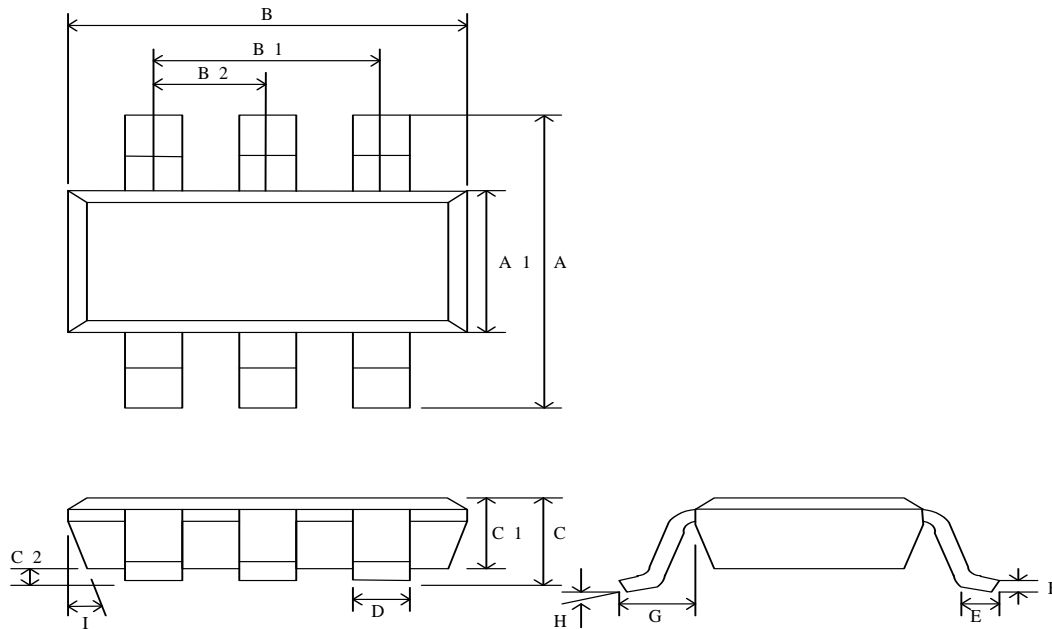

Symbol	Dimension in mm			Dimension in inch		
	Min.	Typ.	Max.	Min.	Typ.	Max.
A	2.60	2.80	3.00	0.102	0.110	0.118
A1	1.40	1.575	1.60	0.055	0.062	0.063
B	2.70	2.85	3.00	0.106	0.112	0.118
B1		1.90(BSC)			0.075(BSC)	
B2		0.95(BSC)			0.037(BSC)	
C	0.95	1.20	1.45	0.037	0.047	0.057
C1	0.90	1.10	1.30	0.035	0.043	0.051
C2	0	0.075	0.150	0	0.003	0.06
D		0.40			0.015	
E	0.30	0.45	0.60	0.012	0.018	0.023
F	0.08	0.15	0.22	0.003	0.006	0.009
G		0.60(REF)				
H				0~8°		
I	5~15°			5~15°		