

PWM Control 3A Step-Down Controller**Features**

- Wide Input Voltage Range: 7V to 18V
- LED Output Current Up to 3A
- With External Power MOSFET
- Soft-start
- Single pin on/off and brightness control
- High efficiency (up to 95%)
- Up to 1MHz switching frequency
- Typical 5% output current accuracy
- SOT-23 Lead-free Package
- Single pin on/off and brightness control using DC voltage or PWM

Applications

- CCTV IR LED Driver
- Lightings
- Portable Communication Devices
- Handheld Electronics

General Description

The T8305 is a continuous mode inductive step-down converter, designed for driving single or multiple series connected LEDs efficiently from a voltage source higher than the LED voltage. The device operates from an input supply between 7V and 18V and provides an externally adjustable output current of up to 3A. Depending upon supply voltage and external components, The T8305 includes the output switch and a high-side output current sensing circuit, which uses an external resistor to set the nominal average output current. The T8305 is available in SOT23 Lead-free package.

Part Number Examples

PART NO.	PACKAGE
T8305BX	SOT23

Pin Arrangement(Top view)

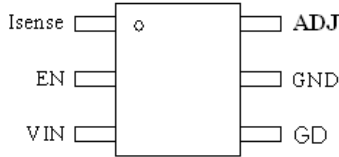

T8305BX
SOT23-6

Pin Description

SYMBOL	SOT23-6	DESCRIPTION
ISENSE	1	Connect resistor R_s from this pin to V_{IN} to define nominal average output current $I_{OUTnom} = 0.2/R_s$
EN	2	Enable control signal, H: Active, L : Power Down
VIN	3	Input voltage . Decouple to ground with 10uF or higher X7R ceramic capacitor close to device
GD	4	External Power MOSFET Gate Driver
GND	5	Ground
ADJ	6	Dimming pin

Absolute Maximum Ratings

Parameter	Symbol	Value	Unit
Voltage on input pin relative to GND	V _{IN}	-0.3 to +20	V
ISENSE pin Voltage		-5 to +0.3	V
EN,ADJ pin Voltage		-0.3 to +6	V
GD pin Voltage		-0.3 to +12	V
Operating Temperature Rang	T _A	-40 to +125	°C
Maximum Soldering Temperature (at leads, 10 sec)	T _{LEAD}	300	°C
Storage Temperature Rang	T _S	-65 to +150	°C
Power debauchery, PD @ TA = 25°C	SOT23	0.35	W
Package Thermal Resistance, θJA	SOT23	250	°C/W

Electrical Characteristics (TA = -40 to 85°C unless otherwise noted. Typical values are at TA =25°C, VDD =12V)

Symbol	Description	Conditions	Min.	Typ.	Max	Unit
V _{IN}	Input Voltage		7	-	18	V
V _{IRU}	Internal regulator start-up threshold	V _{IN} rising		5.65		V
V _{IRD}	Internal regulator shutdown	V _{IN} falling		5.55		V
I _{QOFF}	Quiescent supply current with output off	EN pin grounded		35		uA
I _{QON}	Quiescent supply current with output switching	f = 80kHz		1.8	3.0	mA
V _{SENSE}	Mean current sense threshold Voltage (Defines LED current setting accuracy)	Measured on ISENSE pin with respect to V _{in}	190	200	210	mV
V _{SENTH}	Sense threshold hysteresis			±20		%
I _{SENSE}	ISENSE pin input current	V _{SENSE} = V _{IN} - 0.2		20		uA
V _{REF}	Internal reference voltage			2.5		V
ΔV _{REF} /ΔT	Temperature coefficient of V _{REF}			50		ppm/K
f _{ADJ}	PWM Dimming Frequency	“H” level = 3 or 5V			1	KHz
V _{ADJ}	linear dimming Voltage	V _{ADJ} =2.5V, 100% output current, V _{ADJ} =0.15V, output turn off	0.15		2.5	V
V _{IHEN}	EN Input Voltage Hight		2			V
V _{ILEN}	EN Input Voltage Low				0.5	V
T _r	Rise Time of GD	@Cload = 1600pF		100		ns
T _f	Fall Time of GD	@Cload = 1600pF		100		ns
V _{GD0,H}	GD Pin out Voltage, at High Stage	V _{in} ≥ 12V		12		V
		V _{in} < 12V		V _{in} -2V		V
V _{GD0,L}	GD Pin out Voltage, at Low Stage				0.2	V
T _{TP}	Thermal Shutdown Protect			160		°C

Electrical Characteristics (continuous)					
f _{GD}	Operating frequency	L = 47uH (0.093 ohm) I _O UT=2A @V _{LED} = 3.6V Driving 1 LED		80	KHz
T _{ON} min	Minimum switch 'ON' time	GD High State		3*	us
T _{OFF} min	Minimum switch 'OFF' time	GD Low State		6*	us
T _{ON} minR	Recommended minimum switch 'ON' time	GD High State		12	us
f _{GD} max	Recommended maximum operating frequency			1	MHz
D _{GD}	Recommended duty cycle range of output switch at f _{GD} max		0.3	0.7	
T _{PD}	Internal comparator propagation delay			2	us

Notes :

*Parameters are not tested at production. Parameters are guaranteed by design, characterization and process control.

Block Diagram

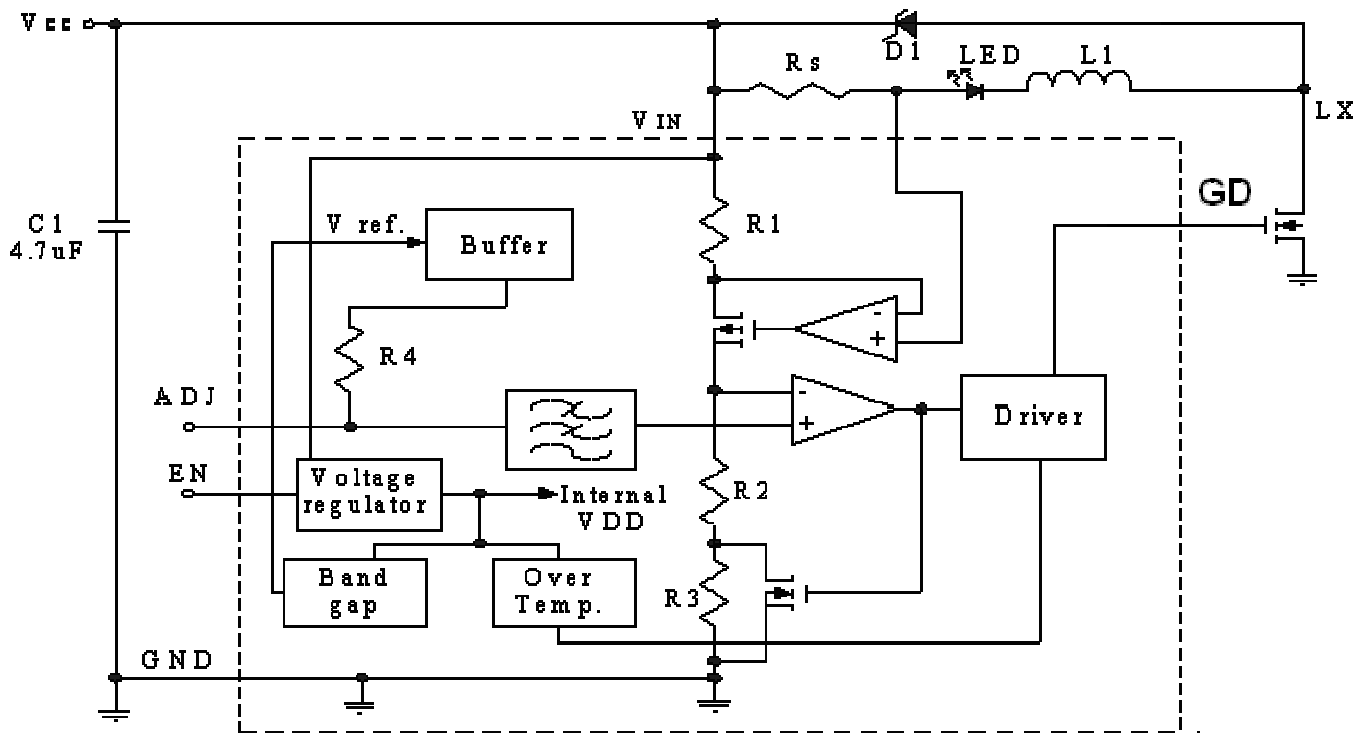

Functional Description

The device, in conjunction with the coil (L1) and current sense resistor (RS), forms a selfoscillating continuous-mode buck converter.

Device operation

Operation can be best understood by assuming that the Vref of the device is unconnected and the voltage on pin appears directly at the (+) input of the comparator.

When input voltage VIN is first applied, the initial current in L1 and RS is zero and there is no output from the current sense circuit. Under this condition, the (-) input to the comparator is at ground and its output is high. This turns MN on and switches the LX pin low, causing current to flow from VIN to ground, via RS, L1 and the LED(s). The current rises at a rate determined by VIN and L1 to produce a voltage ramp (VSENSE) across RS. The supply referred voltage VSENSE is forced across internal resistor R1 by the current sense circuit and produces a proportional current in internal resistors R2 and R3. This produces a ground referred rising voltage at the (-) input of the comparator. When this reaches the threshold voltage, the comparator output switches low and MN turns off. The comparator output also drives another NMOS switch, which bypasses internal resistor R3 to provide a controlled amount of hysteresis. The hysteresis is set by R3 to be nominally 20% .

When MN is off, the current in L1 continues to flow via D1 and the LED(s) back to VIN. The current decays at a rate determined by the LED(s) and diode forward voltages to produce a falling voltage at the input of the comparator. When this voltage returns , the comparator output switches high again. This cycle of events repeats, with the comparator input ramping between limits of $\pm 20\%$.

Switching thresholds

With VREF the ratios of R1, R2 and R3 define an average VSENSE switching threshold of 200mV (measured on the ISENSE pin with respect to VIN). The average output current IOUTnom is then defined by this voltage and RS according to:

$$IOUT_{nom} = 200mV/RS$$

Adjusting output current

The device contains a low pass filter between the ADJ pin and the threshold comparator and an internal current limiting resistor (80kohn nom) between ADJ and the internal reference voltage. This allows the ADJ pin to be overdriven with either DC or pulse signals to change the VSENSE switching threshold and adjust the output current. The filter is third order, comprising three sections, each with a cut-off frequency of nominally 1kHz. Details of the different modes of adjusting output current are given in the applications section.

Output shutdown

The output of the low pass filter drives the shutdown circuit. When the input voltage to this circuit falls below the threshold, the internal regulator and the output switch are turned off. The voltage reference remains powered during shutdown to provide the bias current for the shutdown circuit. Quiescent supply current during shutdown is nominally 35uA and switch leakage is below 5uA.

Applications Information

Setting nominal average output current with external resistor RS

The nominal average output current in the LED(s) is determined by the value of the external current sense resistor (RS) connected between VIN and ISENSE and is given by:

$$I_{OUTnom} = 0.2/RS \text{ [for } RS \geq 0.066 \text{ ohm]}$$

The table below gives values of nominal average output current for several preferred values of current setting resistor (RS) in the typical application circuit :

RS (ohm ±1%)	0.066	0.1	0.132	0.285	0.57
Nominal average output current (mA)	3000	2000	1500	700	350

Note that RS = 0.066ohm is the minimum allowed value of sense resistor under these conditions to maintain switch current below the specified maximum value. It is possible to use different values of RS.

Output current adjustment by external DC control voltage

The ADJ pin can be driven by an external dc voltage (VADJ), as shown, to adjust the output current to a value above or below the nominal average value defined by RS.

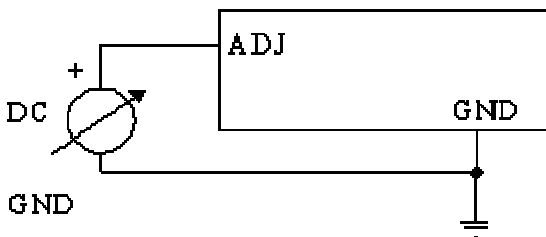

The nominal average output current in this case is given by:

$$I_{OUTdc} = (V_{ADJ}/2.5) \times (0.2V / RS), \text{ [for } 0 < V_{ADJ} < 2.5V]$$

Note that 100% brightness setting corresponds to VADJ = VREF. When driving the ADJ pin above 2.5V, RS must be increased in proportion to prevent IOUTdc exceeding 3A maximum.

The input impedance of the ADJ pin is 80kohm ±25%.

Output current adjustment by PWM control

Directly driving ADJ input

The ADJ pin can be driven by an external dc voltage (VADJ), as shown, to adjust the output current to a value above or below the nominal average value defined by VSENSE.

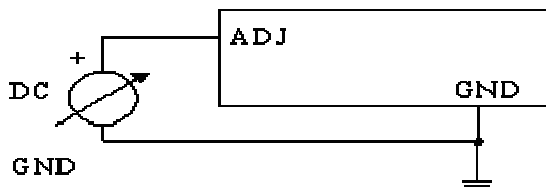

The nominal average output current in this case is given by:

$$I_{OUTdc} = (V_{ADJ}/2.5) \times (0.2V / RFB), \text{ [for } 0.15 < V_{ADJ} < 2.5V]$$

Note that 100% brightness setting corresponds to VADJ ≥ VREF. When driving the ADJ pin above 2.5V.

Output current adjustment by PWM control

Directly driving ADJ input

A Pulse Width Modulated (PWM) signal with duty cycle DPWM can be applied to the ADJ pin, as shown below, to adjust the output current to a value above or below the nominal average value set by resistor V_{SENSE} :

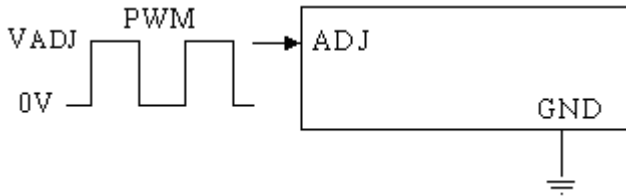

Driving the ADJ input from a microcontroller

Another possibility is to drive the device from the open drain output of a microcontroller. The diagram below shows one method of doing this:

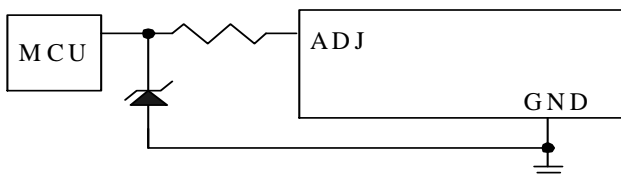

If the NMOS transistor within the microcontroller has high Drain / Source capacitance, this arrangement can inject a negative spike into ADJ input of the T8305 and cause erratic operation but the addition of a Schottky clamp diode (cathode to ADJ) to ground and inclusion of a series resistor (10K) will prevent this. See the section on PWM dimming for more details of the various modes of control using high frequency and low frequency PWM signals.

Dimming Function

A Pulse Width Modulated (PWM) signal with duty cycle DPWM can be applied to the PWM/LD pin, to adjust the output current to a value above or below the nominal average value set ($f < 1\text{kHz}$). The Leave floating for normal operation ($V_{LD}=2.5\text{V}$ giving nominal average output current I_{OUTnom}). The drive with DC voltage ($0.15\text{V} < V_{LD} < 2.5\text{V}$) to adjust output current from 7% to 100% of I_{OUTnom} , If $V_{LD} < 0.15\text{V}$ to turn off output.

Shutdown mode

Taking the EN pin to a voltage below 0.5V for more than approximately 100us, will turn off the output and supply current will fall to a low standby level of 35uA nominal.

Capacitor selection

A low ESR capacitor should be used for input decoupling, as the ESR of this capacitor appears in series with the supply source impedance and lowers overall efficiency. This capacitor has to supply the relatively high peak current to the coil and smooth the current ripple on the input supply. A minimum value of 47uF is acceptable if the input source is close to the device, but higher values will improve performance at lower input voltages, especially when the source impedance is high. In order to avoid high frequency noise influence and improve circuit stability, it is recommended to shunt a value of 0.22uF Capacitor. The input capacitor should be placed as close as possible to the IC. For maximum stability over temperature and voltage, capacitors with X7R, X5R, or better dielectric are recommended. Capacitors with Y5V dielectric are not suitable for decoupling in this application and should not be used.

Inductor selection

Recommended inductor values for the T8305 are in the range 33uH to 100uH. Higher values of inductance are recommended at higher supply voltages in order to minimize errors due to switching delays, which result in increased ripple and lower efficiency. Higher values of inductance also result in a smaller change in output current over the supply voltage range. The inductor should be mounted as close to the device as possible with low resistance connections to the LX and VIN pins. The chosen coil should have a saturation current higher than the peak output current and a continuous current rating above the required mean output current.

The inductor value should be chosen to maintain operating duty cycle and switch 'on'/'off' times within the specified limits over the supply voltage and load current range.

LX switch on time : $t_{on} = L\Delta I / (V_{IN} - V_{LED} - I_{avg} (R_S + r_L + R_{LX}))$,

LX switch off time : $t_{off} = L\Delta I / (V_{LED} + V_D + I_{avg} (R_S + r_L))$,

Where:

“L” is the coil inductance (H)

“ΔI” is the coil peak-peak ripple current (A) {Internally set to 0.3 x I_{avg}}

“rL” is the coil resistance (ohm)

“RS” is the current sense resistance

“I_{avg}” is the required LED current (A)

“VIN” is the supply voltage (V)

“VLED” is the total LED forward voltage (V)

“RLX” is the switch resistance (ohm) {=0.2 ohm nominal}

“VD” is the diode forward voltage at the required load current (V)

Typical Application Circuits

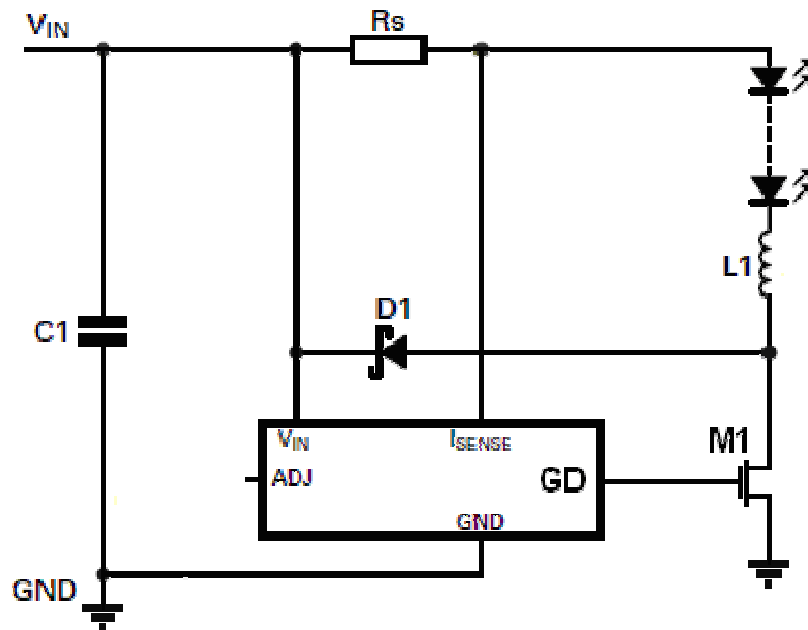

Package Dimensions
SOT-23-6

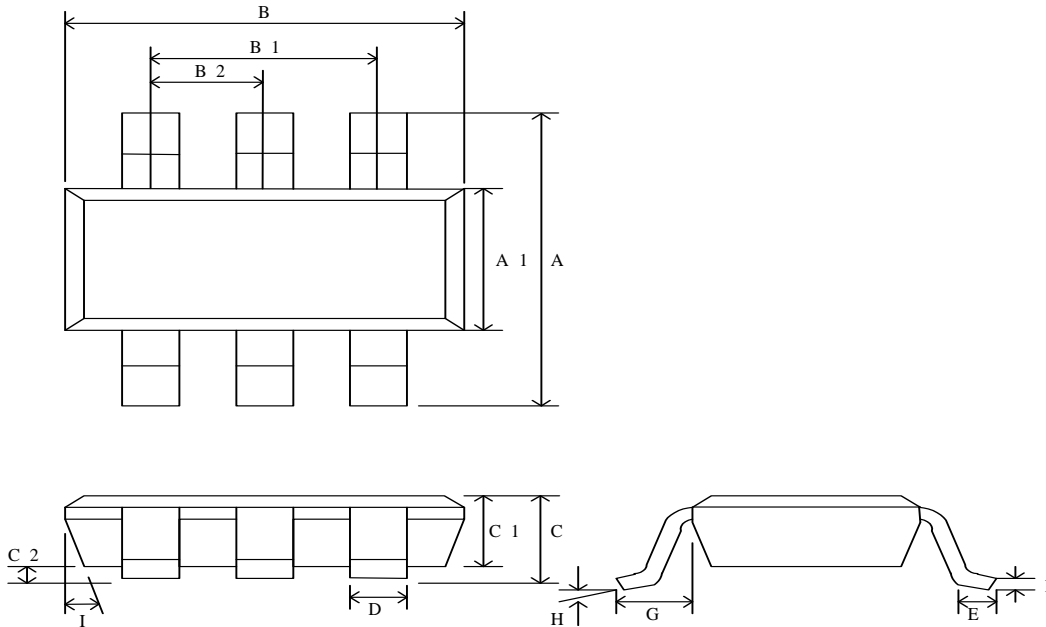

Symbol	Dimension in mm			Dimension in inch		
	Min.	Typ.	Max.	Min.	Typ.	Max.
A	2.60	2.80	3.00	0.102	0.110	0.118
A1	1.40	1.575	1.60	0.055	0.062	0.063
B	2.70	2.85	3.00	0.106	0.112	0.118
B1		1.90(BSC)			0.075(BSC)	
B2		0.95(BSC)			0.037(BSC)	
C	0.95	1.20	1.45	0.037	0.047	0.057
C1	0.90	1.10	1.30	0.035	0.043	0.051
C2	0	0.075	0.150	0	0.003	0.06
D		0.40			0.015	
E	0.30	0.45	0.60	0.012	0.018	0.023
F	0.08	0.15	0.22	0.003	0.006	0.009
G		0.60(REF)				
H				0~8°		
I	5~15°			5~15°		