PWM Control 1500mA Step-Down Converter
Built-sensitive switch hysteresis control function

FEATURES

- Wide Input Voltage Range: 4.5V to 30V
- LED Output Current Up to 1500mA
- Soft-start
- Single pin on/off and brightness control using DC voltage or PWM
- High efficiency (up to 97%)
- CCTV IR LED Driver add CDS control Built-sensitive switch hysteresis control function
- Up to 1MHz switching frequency
- Typical 5% output current accuracy. By sense resistor $\pm 1\%$
- SOP-8 Lead-free Package

Applications

- LED/Display Back Light Driver
- Lightings
- Portable Communication Devices
- Handheld Electronics
- CCTV IR LED Driver

GENERAL DESCRIPTION

The T8309AD is a continuous mode inductive step-down converter, designed for driving single or multiple series connected LEDs efficiently from a voltage source higher than the LED voltage. The device operates from an input supply between 4.5V and 30V and provides an externally adjustable output current of up to 1500mA. Depending upon supply voltage and external components, this can provide up to 40 watts of output power. The T8309AD includes the output switch and a high-side output current sensing circuit, which uses an external resistor to set the nominal average output current. The T8309AD is available in SOP-8 Lead-free package.

PART NUMBER EXAMPLES

PART NO.	PACKAGE
T8309AD	SOP-8

PIN ARRANGEMENT(Top view)

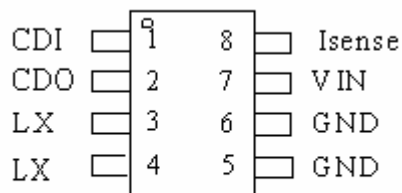

**T8309AD
SOP-8**

PIN DESCRIPTION

Symbol	SOP-8	Description
LX	3,4	Drain of NMOS switch ONE PIN MAX 1A load current
GND	5,6	Ground
CDI	1	CDS Application Input & Enable control signal, H: Active, L: Power Down · CDI longer than 3 seconds, to maintain a high voltage
CDO	2	Enable Application Output for IR Cut Driver
ISENSE	8	Connect resistor R_s from this pin to VIN to define nominal average output current $I_{OUTnom} = 0.1/R_s$
VIN	7	Input voltage (4.5V to 30V). Decouple to ground with 47uF or higher X7R ceramic capacitor close to device.

ABSOLUTE MAXIMUM RATINGS

Parameter	Symbol	Value	Unit
Voltage on input pin relative to GND	V _{IN}	-0.3 to +40	V
ISENSE pin Voltage		-5 to +0.3	V
CDI pin & CDO pin Voltage		-0.3 to +6	V
Operating pn junction Temperature Range	T _j	-40 to 150	°C
Operating Temperature Range	T _A	-40 to 105	°C
Maximum Soldering Temperature (at lead, 10sec)	T _{LEAD}	300	°C
Storage Temperature Range	T _s	-65 to +150	°C
Power Dissipation, PD @ TA=25°C	SOP-8	0.8	W
Package Thermal Resistance, θJA	SOP-8	50	°C/W

Electrical Characteristics

(TA=-40 to 105°C unless otherwise noted. Typical values are at TA=25°C, VDD=24V)

Symbol	Description	Conditions	Min.	Typ.	Max.	Unit
V _{IN}	Input voltage		4.5	-	30	V
U _{VLO}	Under Voltage lock out			3.6		V
V _{IRU}	Internal regulator start-up threshold	V _{IN} rising		3.65		V
V _{IRD}	Internal regulator shutdown	V _{IN} falling		3.55		V
I _{QOFF}	Quiescent supply current with output off	CDI&CDO pin grounded		170		uA
I _{QON}	Quiescent supply current with output switching	CDI&CDO pin floating fsw= 250kHz		1.8	5	mA
I _{SENSE}	Mean current sense threshold voltage (Defines LED current setting accuracy)	Measured on I _{SENSE} pin with respect to V _{IN}	95	100	105	mV
I _{SENTH}	Sense threshold hysteresis			±15		%
	System current hysteresis	I _{OUT} =0.5A~1.5A			±25	%
I _{SENSE}	I _{SENSE} pin input current	V _{SENSE} = V _{IN} -0.1		10		uA
ΔV _{REF} /ΔT	Temperature coefficient of VREF			50		ppm/K
V _{CDO}	CDO Output Voltage			5		
V _{OH CDO}	CDO Output Voltage High	Output High Current <400 μA	2	5		V
V _{OL CDO}	CDO Output Voltage Low	TTL OUTPUT		0	0.8	V
V _{CDI VP}	CDI Positive Trigger Threshold Voltage (Note2)		1.8	2		V
V _{CDI VN}	CDI Negative Trigger Threshold Voltage (Note2)			0.8	1	V

$V_{CDI} V_H$	Hysteresis Voltage (Note2)			1.2		V
$T_{CDI} V_{TH}$	High Hold up time (Note3)	$V_{CDI} > 2V$	1.2	1.5		S
$T_{CDI} V_{TN}$	Low Hold time	$V_{CDI} < 0.8V$		30		uS
V_{DT}	Slow start	$V_{ref}=1.25V$		300		μS
I_{LXM}	Continuous LX switch current(Note1)	$T_A=25^\circ C$ Two Pin			1.5	A
R_{LX}	LX Switch 'On' resistance	$V_{IN} 12V @ I_{LX}=1.5A$ SOP -8		0.4	0.45	Ω
I_{LXI}	LX switch leakage current				5	uA
T_{TP}	Thermal Shutdown Protect			155	160	$^\circ C$
f_{LX}	Operating frequency	CDI/CDO pin floating, $L=33\mu H(0.093\text{ohm})$ $I_{OUT}=1.5A @ V_{LED}=3.6V$ Driving 1LED		280		KHz
T_{ONmin}	Minimum switch 'ON' time	LX switch 'ON'		240		ns
T_{OFFmin}	Minimum switch 'OFF' time	LX switch 'OFF'		200		ns
T_{PWmin}	minimum switch 'ON' time	LX switch 'ON' or 'OFF'		800		ns
f_{LXmax}	maximum operating frequency				1	MHz
D_{LX}	Recommended duty cycle range of output switch at Flx max		0.2		0.9	
T_{PD}	Internal comparator propagation delay			50		ns

Notes :

**Note1. Operating temperature $25^\circ C$ and adequate cooling conditions, the temperature, the higher the maximum current decreasing

**Note2

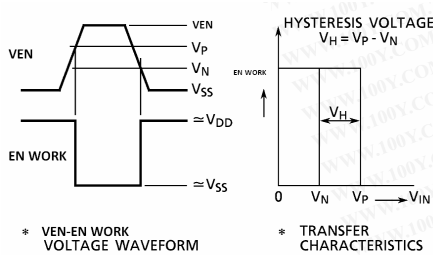

CDI HYSTERESIS

**Note3

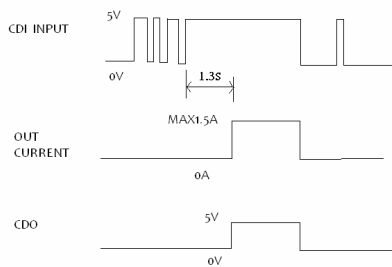

CDI&CDO Timing Diagram

Block Diagram

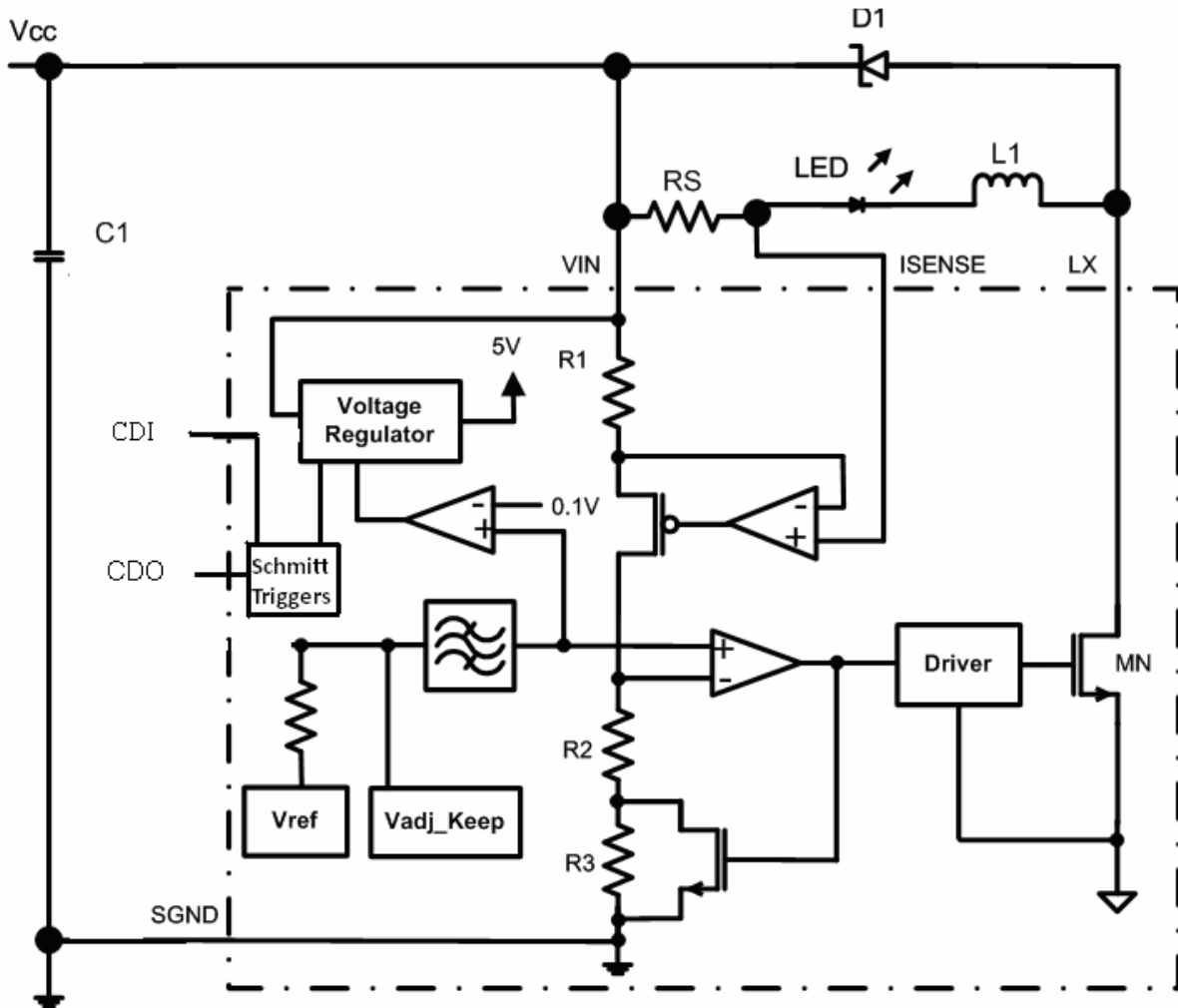

Functional Description

The device, in conjunction with the coil (L1) and current sense resistor (RS), forms a selfoscillating continuous-mode buck converter.

Device operation

Operation can be best understood by assuming that the EN pin of the device is unconnected and the voltage on this pin (V_{CDI}) appears directly at the (+) input of the comparator °

When input voltage V_{IN} is first applied, the initial current in L1 and RS is zero and there is no output from the current sense circuit. Under this condition, the (-) input to the comparator is at ground and its output is high. This turns MN on and switches the LX pin low, causing current to flow from V_{IN} to ground, via RS, L1 and the LED(s). The current rises at a rate determined by V_{IN} and L1 to produce a voltage ramp (V_{SENSE}) across RS. The supply referred voltage V_{SENSE} is forced across internal resistor R1 by the current sense circuit and produces a proportional current in internal resistors R2 and R3. This produces a ground referred rising voltage at the (-) input of the comparator. When MN is off, the current in L1 continues to flow via D1 and the LED(s) back to V_{IN} . The current decays at a rate determined by the LED(s) and diode forward voltages to produce a falling voltage at the input of the comparator.

Switching thresholds

Define an average V_{SENSE} switching threshold of 100mV (measured on the ISENSE pin with respect to V_{IN}). The average output current I_{OUTnom} is then defined by this voltage and RS according to:

$$I_{OUTnom} = 100mV/RS$$

Nominal ripple current is $\pm 15mV/RS$

Output shutdown

The output of the low pass filter drives the shutdown circuit. When the input voltage to this circuit falls below the threshold, the internal regulator and the output switch are turned off. The voltage reference remains powered during shutdown to provide the bias current for the shutdown circuit. Quiescent supply current during shutdown is nominally 35uA and switch leakage is below 5uA.

Applications Information

Setting nominal average output current with external resistor RS

The nominal average output current in the LED(s) is determined by the value of the external current sense resistor (RS) connected between VIN and ISENSE and is given by:

$$I_{OUTnom} = 0.1/RS \text{ [for } RS \geq 0.066 \text{ ohm} \pm 1\%]$$

The table below gives values of nominal average output current for several preferred values of current setting resistor (RS) in the typical application circuit :

RS (ohm) $\pm 1\%$	0.066	0.125	0.2	0.285
Nominal average output current (mA)	1500	800	500	350

The above values assume that the EN pin is floating.

Shutdown mode

Taking the CDI pin to a voltage below 0.8V for more than approximately 100us, will turn off the output and supply current will fall to a low standby level of 35uA nominal.

Capacitor selection

A low ESR capacitor should be used for input decoupling, as the ESR of this capacitor appears in series with the supply source impedance and lowers overall efficiency. This capacitor has to supply the relatively high peak current to the coil and smooth the current ripple on the input supply. A minimum value of 47uF is acceptable if the input source is close to the device, but higher values will improve performance at lower input voltages, especially when the source impedance is high. In order to avoid high frequency noise influence and improve circuit stability, it is recommended to shunt a value of 0.22uF Capacitor. The input capacitor should be placed as close as possible to the IC. For maximum stability over temperature and voltage, capacitors with X7R, X5R, or better dielectric are recommended. Capacitors with Y5V dielectric are not suitable for decoupling in this application and should not be used.

Inductor selection

Recommended inductor values for the T8309AD are in the range 33uH to 100uH. Higher values of inductance are recommended at higher supply voltages in order to minimize errors due to switching delays, which result in increased ripple and lower efficiency. Higher values of inductance also result in a smaller change in output current over the supply voltage range. The inductor should be mounted as close to the device as possible with low resistance connections to the LX and VIN pins. The chosen coil should have a saturation current higher than the peak output current and a continuous current rating above the required mean output current.

The inductor value should be chosen to maintain operating duty cycle and switch 'on'/'off' times within the specified limits over the supply voltage and load current range.

$$\text{LX switch on time : } t_{on} = L\Delta I / (V_{IN} - V_{LED} - I_{avg} (R_S + r_L + R_{LX})) , \text{ note: } t_{on} \text{ min} > 240\text{ns}$$

$$\text{LX switch off time : } t_{off} = L\Delta I / (V_{LED} + V_D + I_{avg} (R_S + r_L)) , \text{ note: } t_{off} \text{ min} > 200\text{ns}$$

Where:

“L” is the coil inductance (H)

“ ΔI ” is the coil peak-peak ripple current (A) {Internally set to $0.3 \times I_{avg}$ }

“ r_L ” is the coil resistance (ohm)

“ R_S ” is the current sense resistance

“ I_{avg} ” is the required LED current (A)

“ V_{IN} ” is the supply voltage (V)

“ V_{LED} ” is the total LED forward voltage (V)

“ R_{LX} ” is the switch resistance (ohm) {=0.4 ohm nominal}

“ V_D ” is the diode forward voltage at the required load current (V)

TYPICAL APPLICATION CIRCUITS

CDS Control

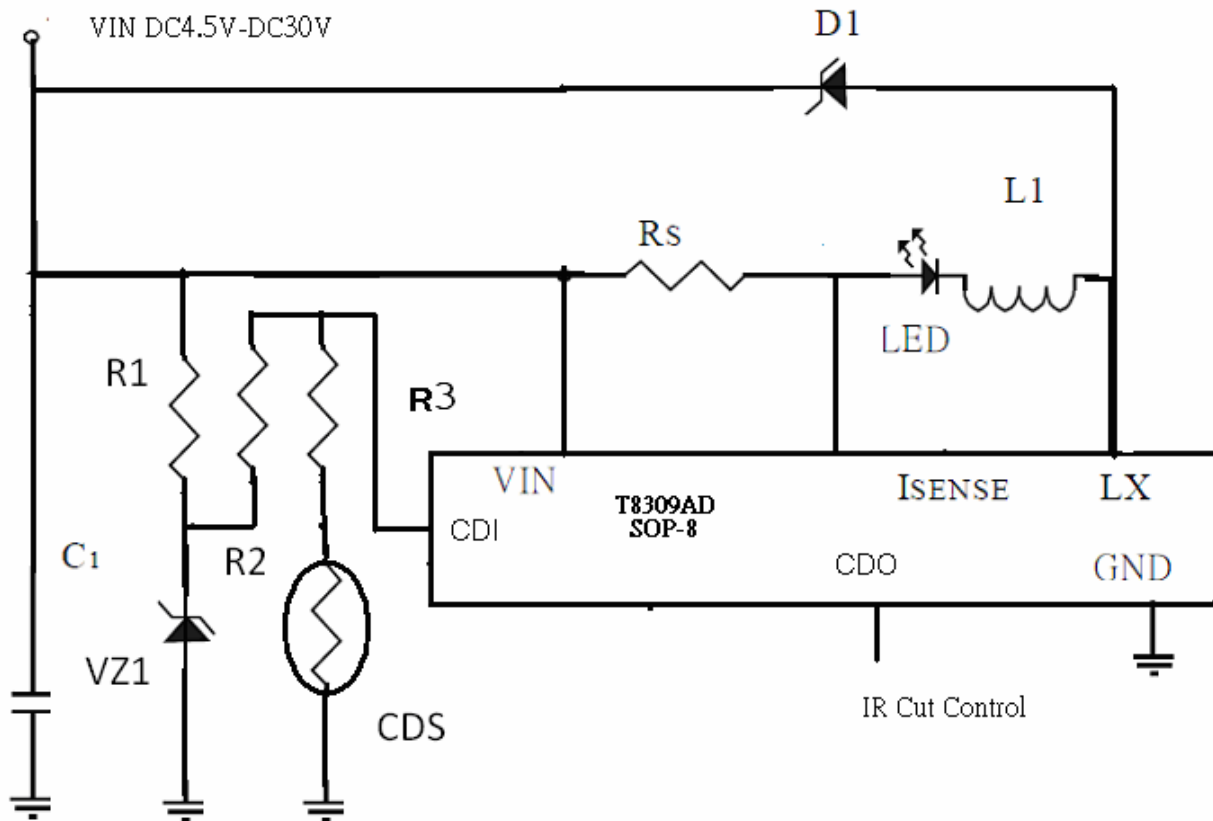

* note : When outputs the big current, the noise are big, this and the system environment and PCB layout have the influential, may defer to the actual need to increase the capacitor filtration noise.

**PACKAGE DIMENSIONS
8-LEAD SOP**

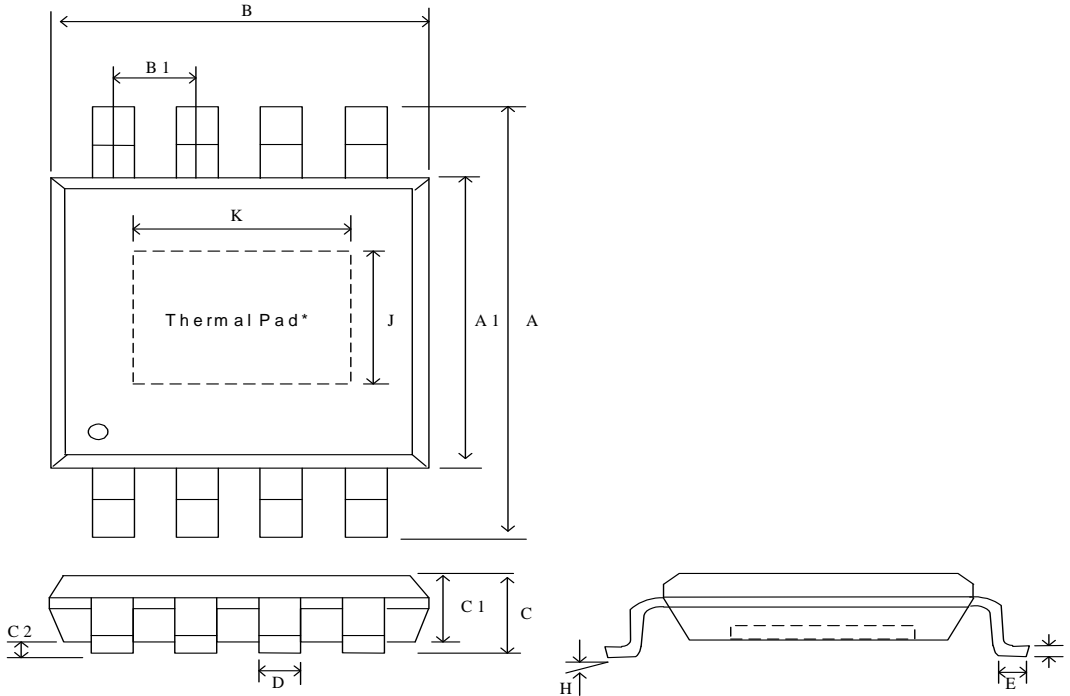

Symbol	Dimension in mm			Dimension in inch		
	Min.	Typ.	Max.	Min.	Typ.	Max.
A	5.70	6.00	6.30	0.224	0.236	0.248
A1	3.75	3.95	4.10	0.148	0.156	0.164
B	-	-	5.13	-	-	0.202
B1	-	1.27	-	-	0.050	-
C	-	-	1.80	-	-	0.071
C1	1.35	1.55	1.75	0.052	0.061	0.069
C2	0	-	0.15	0.000	-	0.006
D	0.31	0.41	0.51	0.012	0.016	0.020
E	0.30	0.50	0.70	0.012	0.020	0.028
F	0.10	0.15	0.25	0.004	0.006	0.010
J		2.23 REF			0.088 REF	
K		2.97 REF			0.117 REF	
H	0~8°			0~8°		

***Note :**

The thermal pad on the IC's bottom has to be mounted on the copper foil.

To eliminate the noise influence, the thermal pad is suggested to be connected to GND on PCB.

In addition, desired thermal conductivity will be improved, if a heat-conducting copper foil on PCB is soldered with thermal pad. The thermal pad enhances the power dissipation. As a result, a large amount of current can be sunk safely in one package.