

100W Linear LED Driver**FEATURES**

- Flexible Voltage Detect
- Current Operation: 500mA / 110Vac, 500mA / 220Vac
- 110Vac / 220Vac Single Power Supply Voltage Range
- LED Brightness Stable
- Over Temperature Protection
- Surge Protection
- QFN7X7-48 – Package

Applications

- Solid State Lighting
- Bulbs, Tubes
- Small Form Factor condition
- Street light
- Down Light, Spot Light

GENERAL DESCRIPTION

The T8616AN is an off-line linear LED constant power driver. The application of high bright LED is widely used for general illumination.

The T8616AN can drive a plurality of LED strings. When the voltage detecting circuit detects the different voltage level of input voltage, T8616AN can auto switch the LED work strings. If the input voltage is lower than the V_f of the LED string that it will bypass the LED string. And turn on all LED strings when the input voltage is higher than the V_f of total LED strings. The number of LEDs in LED array is dependent on the voltage level of the AC power source that includes of $\pm 10V$ variations. A typical application for the T8616AN is to drive LEDs with a constant power of 10W to 50W for 100~120Vac input, and 10W to 100W for 200~240Vac input, which depend on the setting current.

PART NUMBER EXAMPLES

PART NO.	PACKAGE
T8616AN	QFN7X7- 48

This document is for reference only.

Operation methodology:

(1). T8616AN Driver Schematic:

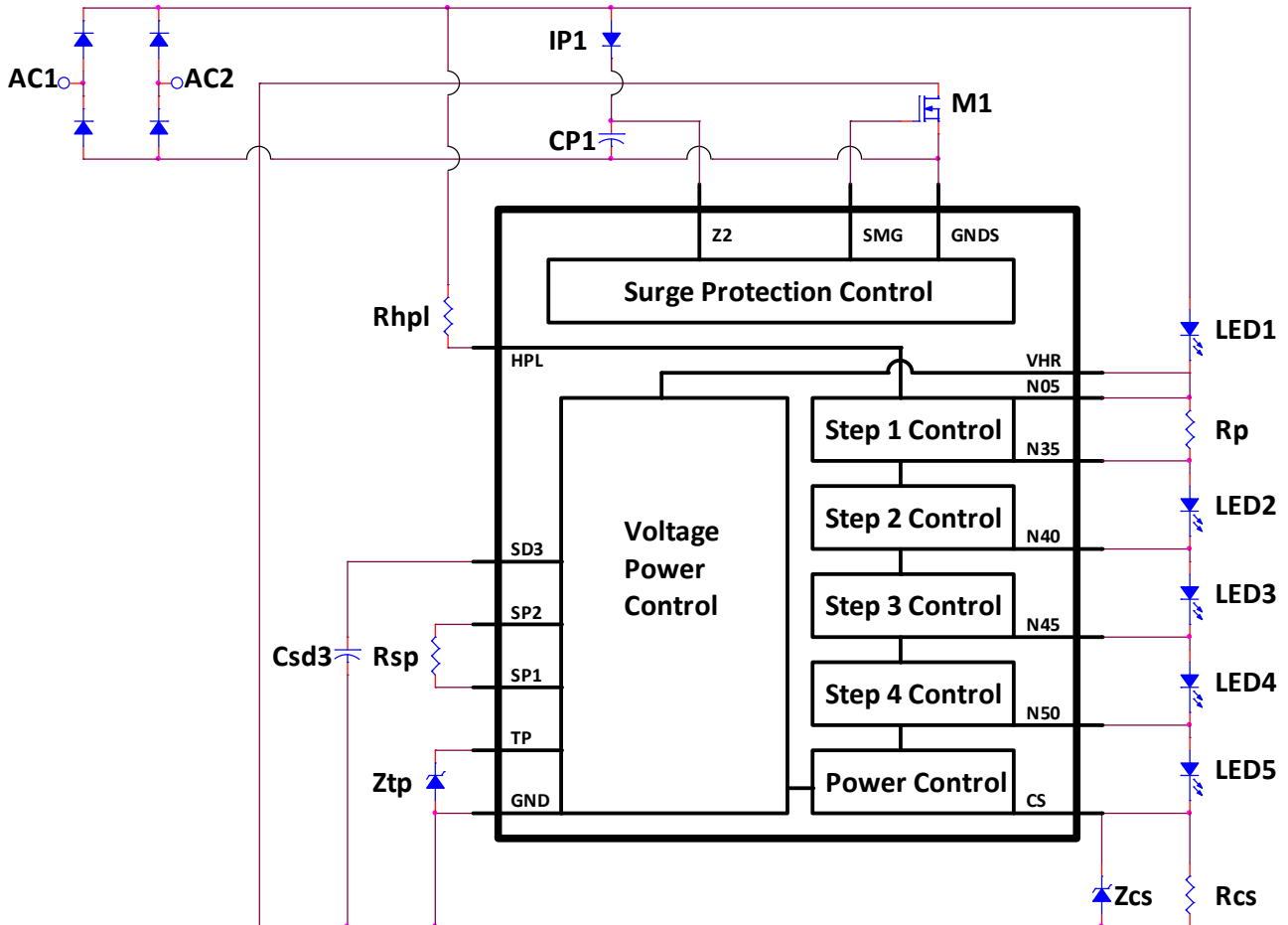

The voltage waveform from AC through bridge, and each LED chain ON/OFF situation are shown as the plot.

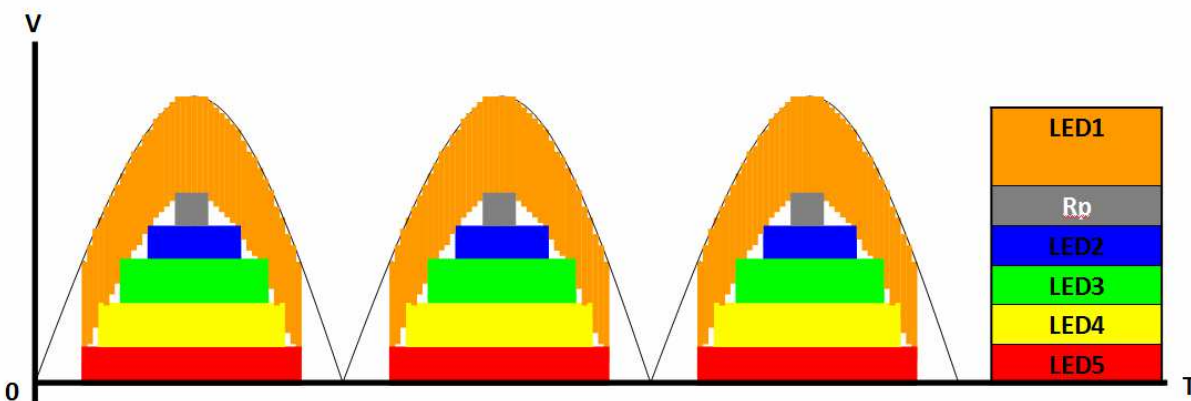

This document is for reference only.

(2). Main chains operation during input voltage variation: 5 LED chains are in serial, and the IC defines the current flow base on the input voltage to fit the best power efficiency.

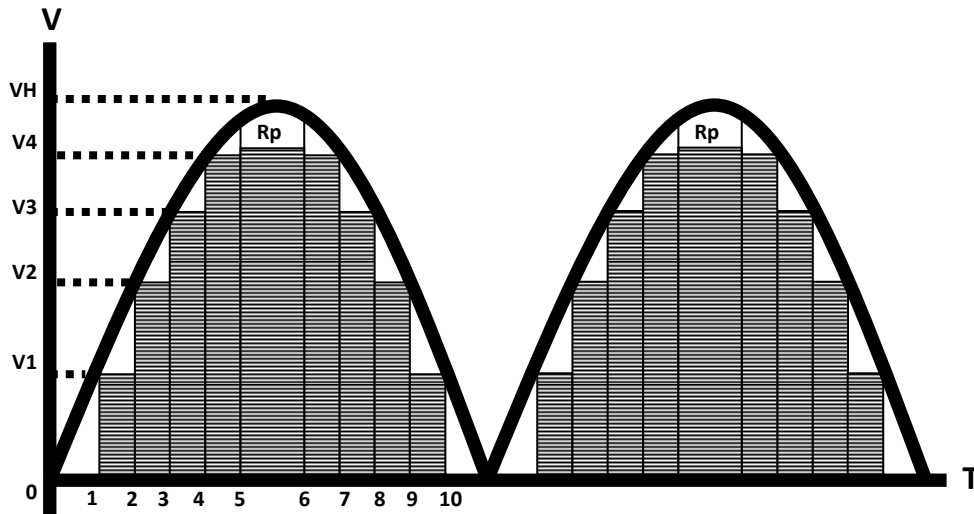

The following is the LEDs operation sequence description:

1. When voltage growth higher than V1, but lower than V2, current flow through LED1, IC inside, LED5, and current sense resistor Rcs
2. When voltage higher than V2, but lower than V3, current flow through LED1, IC inside, LED4, LED5, and current sense resistor Rcs
3. When voltage higher then V3, but lowers than V4, current flow through LED1, IC inside, LED3, LED4, LED5, and current sense resistor Rcs
4. When voltage higher then V4, current flow through LED1, IC inside, LED2, LED3, LED4, LED5, and current sense resistor Rcs.
5. When voltage go even higher, part of current will flow through Rp to lower down the current inside IC.
6. When current down and near to V4, current back to flow through LED1, IC inside, LED2, LED3, LED4, LED5, and current sense resistor Rcs.
7. When voltage lower then V4, but higher than V3, current flow through LED1, IC inside, LED3, LED4, LED5, and current sense resistor Rcs.
8. When voltage lower than V3, but higher than V2, current flow through LED1, IC inside, LED4, LED5, and current sense resistor Rcs.
9. When voltage lower than V2, but higher than V1, current flow through LED1, IC inside, LED5, and current sense resistor Rcs.

T \ LED	0	1	2	3	4	5	6	7	8	9	10
1	Off	ON	ON	ON	ON	ON	ON	ON	ON	ON	off
Rp	Off	Off	off	off	off	ON	off	off	off	off	Off
2	Off	Off	off	off	ON	ON	ON	off	off	off	Off
3	Off	Off	off	ON	ON	ON	ON	ON	off	off	Off
4	Off	off	ON	ON	ON	ON	ON	ON	ON	off	Off
5	off	ON	ON	ON	ON	ON	ON	ON	ON	ON	off

This document is for reference only.

PIN ARRANGEMENT (Top view)

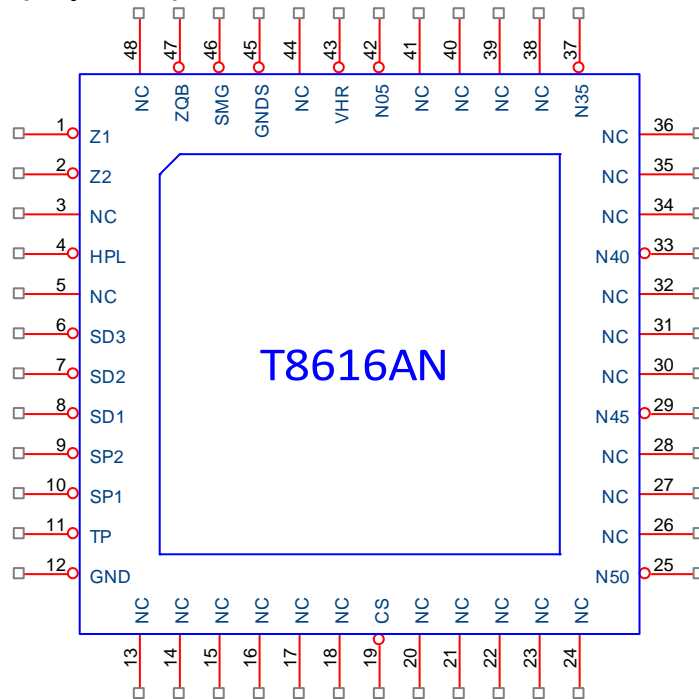

PIN DESCRIPTION

SYMBOL	QFN7X7-48	DESCRIPTION
ZQB	47	Surge Protection Control Monitor
Z1	1	AC 110V Surge Protection Control Input
Z2	2	AC 220V Surge Protection Control Input
HPL	4	Low voltage input
SD3	6	Sense Power pin, built in fixed power control
SD2	7	Sense Power pin, built in fixed power control
SD1	8	Sense Power pin, built in fixed power control
SP2	9	Sense Power pin, built in fixed power control
SP1	10	Sense Power pin, built in fixed power control
TP	11	External reference voltage source (using Zener Diodes 5.6V)
GND	12	Ground
CS	19	System current sense pin
N50	25	Block 5 reference ground (GND5)
N45	29	Block 4 reference ground (GND4)
N40	33	Block 3 reference ground (GND3)
N35	37	Block 3 Add a pin
N05	42	Block 2 reference ground (GND2)
VHR	43	High voltage reference
GNDS	45	Surge Protection Control Ground
SMG	46	Surge Protection Control Output

This document is for reference only.

ABSOLUTE MAXIMUM RATINGS

Parameter	Symbol	Value	Unit
The difference voltage of N35-N40, N50-CS (for large current rating)	V _{MAX}	+25	V
The difference voltage of N40-N45 , N45-N50 (for large current rating)	V _{MAX}	+45	V
The difference voltage of N05-N35 (for large current rating)	V _{MAX}	+60	V
Operating ambient temperature range	T _A	-40 to +85	°C
Operating maximum junction temperature	T _J	150	°C
Maximum soldering temperature (at leads, 10 sec)	T _{LEAD}	260	°C
Storage temperature range	T _{Stg}	-65 to +150	°C
ESD Rating Human Body Model		±1.5	KV
Thermal resistance junction to case (θ _{JC})	QFN7X7-48	0.5	°C/W
Thermal resistance junction to ambient (θ _{JA})	QFN7X7-48	29	°C/W
Note: (Assume no ambient airflow) Absolute Maximum Ratings are those values beyond which the life of a device may be impaired. *The package is place on a two layers PCB with 2 ounces copper and 2 square inch, connected by 8 vias.			

This document is for reference only.

Electrical Characteristics

(T_A = -40 to 85°C unless otherwise noted. Typical values are at T_A =25°C)

(Note 1)

Symbol	Description	Conditions	Min.	Typ.	Max	Unit
System Controller Unit						
V _{HPL}	Input max Voltage				200	V
V _{VHR}	Pre-Regulation Voltage				200	V
V _{SD3}	Sense Power voltage	INPUT current < 20uA	100		200	V
V _{SD2}	Sense Power voltage	INPUT current < 20uA	100		200	V
V _{SD1}	Sense Power voltage	INPUT current < 20uA	100		150	V
V _{SP2}	Sense Power voltage	INPUT current < 20uA	30		100	V
V _{SP1}	Sense Power voltage	INPUT current < 20uA	20		90	V
V _{TP}	External reference voltage source (using Zener Diodes)	INPUT Current < 1mA	5.4	5.6	5.8	V
V _{CS}	Current Sense voltage		0		7	V
	lout accuracy			10		%
	PIN vs Temperature	-20°C > Temp < +85°C		10		%

Note 1: Specifications are production tested at T_A=25°C. Specifications over the -40°C to 85°C operating temperature range are assured by design, characterization and correlation with Statistical Quality Controls (SQC).

Note 2: Output LED Current = peak to peak.

This document is for reference only.

Application informations

The T8616AN is off-line constant power LED driver. It can drive a plurality of LED strings. The T8616AN can flexibly control the LED strings according to the variance of input voltage. If the input voltage is lower, it will bypass some LED strings. When the input voltage is higher than the total forward voltage of all LED strings, all LED strings will be turned on. The number of LEDs in LED array is dependent on the voltage level of the AC power source. Multiple T8616AN can also be used in parallel to provide higher LED current.

The detail application circuit and methodology please reference to the "Application Notes".

Thermal regulation

The T8616AN includes the thermal-regulation circuit, which were designed to protect the device from excessive temperature. The internal thermal-regulation circuit adjusts the LED current if the junction temperature rises above the preset value (about 140°C).

Power dissipation

The maximum power dissipation of T8616AN depends on the thermal resistance of its case and circuit board, the temperature difference between the die junction and ambient air, and the rate of airflow. The rate of temperature rise is greatly affected by the mounting pad configuration on the PCB, the board material, and the ambient temperature. When the IC mounting with good thermal conductivity is used, the junction temperature will be low even when large power dissipation applies.

As a general rule, the lower temperature is, the better reliability of the device is. So the PCB mounting pad should provide maximum thermal conductivity to maintain low device temperature.

This document is for reference only.

PACKAGE DIMENSIONS

QFN7X7-48L

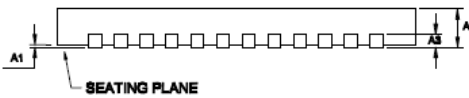
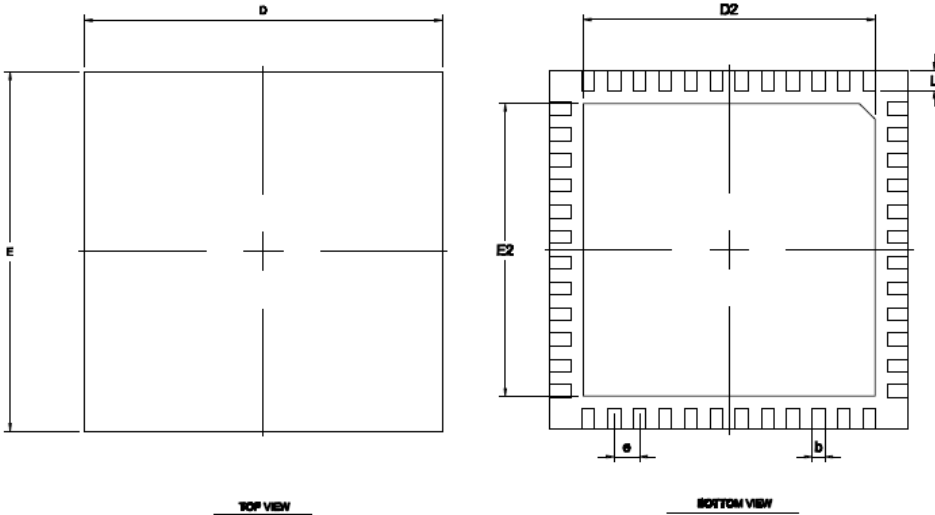

Symbol	DIMENSION (MM)			DIMENSION Inch		
	Min	Nom.	Max	Min	Nom.	Max
A	0.70	0.75	0.80	0.028	0.030	0.031
A1	0.00	0.02	0.05	0.000	0.001	0.002
A3	0.203 REF			0.008 REF		
b	0.18	0.25	0.30	0.007	0.010	0.012
D	6.90	7.00	7.10	0.272	0.276	0.280
D2	5.60	5.70	5.80	0.220	0.224	0.228
E	6.90	7.00	7.10	0.272	0.276	0.280
E2	5.60	5.70	5.80	0.220	0.224	0.228
e	0.50 BSC			0.020BSC		
L	0.30	0.40	0.50	0.012	0.016	0.020

Note:

1. Refer to JEDEC MS-012E.
2. Dimension "D" does not include mold flash, protrusions or gate burrs. Mold flash, protrusion or gate burrs shall not exceed 6 mil per side.
3. Dimension "E" does not include inter-lead flash or protrusions.
4. Controlling dimension is millimeter, converted inch dimensions are not necessarily exact.