



P3576

LINEAR INTEGRATED CIRCUIT

50KHz, 2A PWM BUCK DC/DC CONVERTER

DESCRIPTION

The UTC **P3576** series is a step-down switching regulator which is able to provide 2A output current. The available versions of output voltage are 2.5V, 3.3V, 5V, 12V and adjustable.

FEATURES

- * Output load current: 2A
- * Adjustable version output voltage range, 1.23V ~ 38.5V±4%
- * Operating voltage can be up to 40V
- * Low power standby mode
- * High efficiency
- * Internal current and thermal limit
- * Built-in Switching Transistor On Chip.

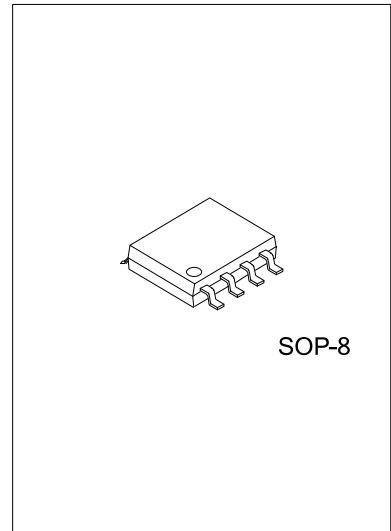

ORDERING INFORMATION

Ordering Number	Package	Packing
P3576G-xx-S08-R	SOP-8	Tape Reel

Note: xx: Output Voltage, Refer to Marking Information

<p>P3576G-xx-S08-R</p> <ul style="list-style-type: none"> (1) Packing Type (2) Package Type (3) Output Voltage Code (4) Green Package 	<ul style="list-style-type: none"> (1) R: Tape Reel (2) S08: SOP-8 (3) xx: refer to Marking information (4) G: Halogen Free and Lead Free
---	---

MARKING INFORMATION

PACKAGE	VOLTAGE CODE	MARKING
SOP-8	15 : 1.5V 33 : 3.3V 50 : 5.0V AD: ADJ	

PIN CONFIGURATION

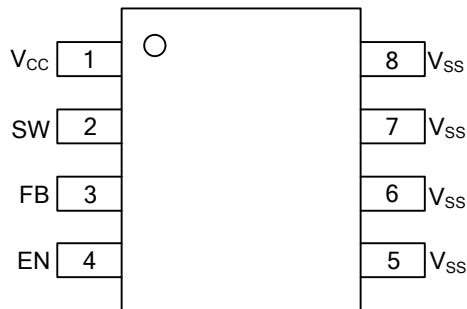

PIN DESCRIPTION

PIN NO.	PIN NAME	DESCRIPTION
1	V _{CC}	Operating voltage input
2	SW	Switching output
3	FB	Output voltage feedback control
4	EN	ON/OFF Shutdown
5~8	V _{SS}	GND pin

■ BLOCK DIAGRAM

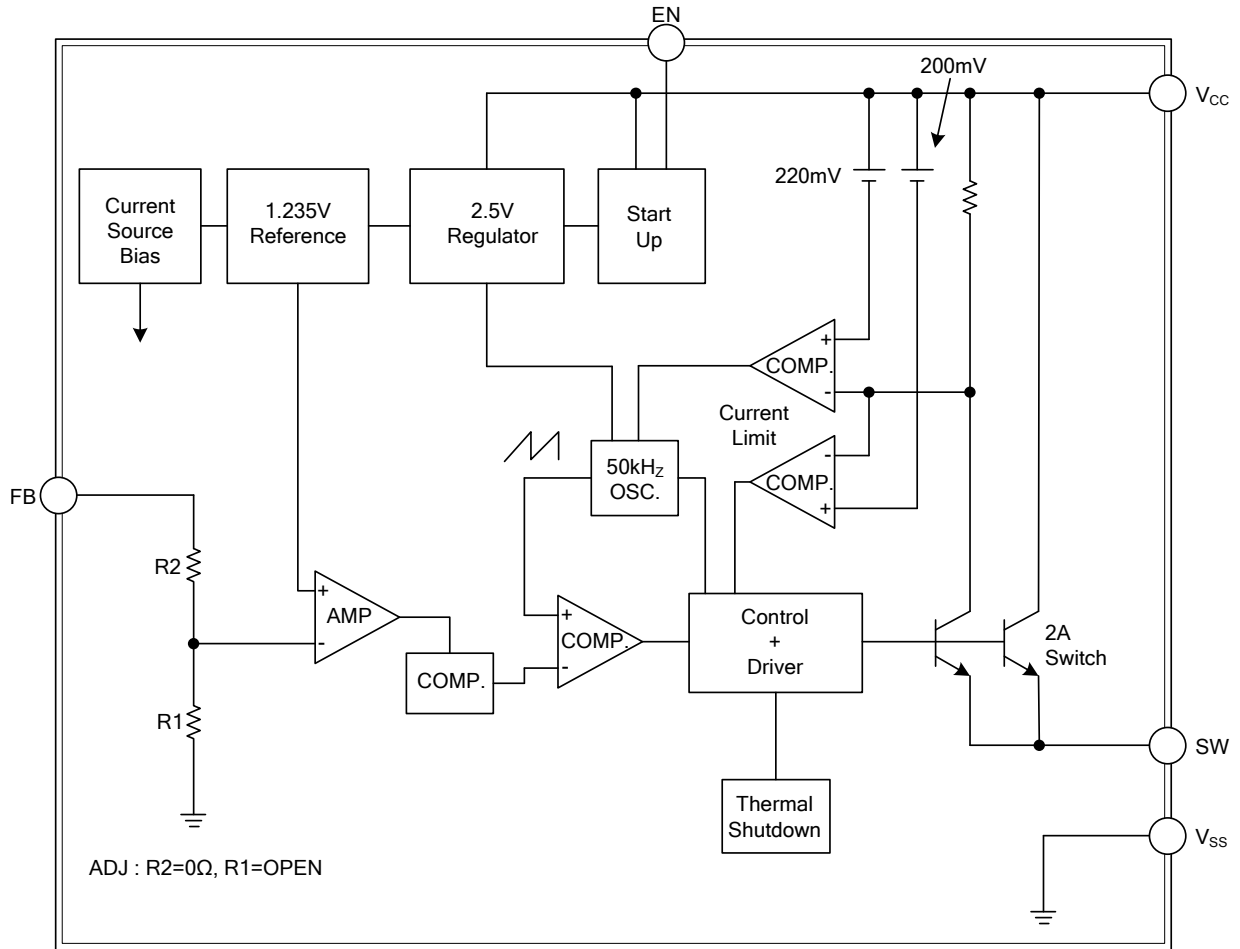

■ ABSOLUTE MAXIMUM RATING (T_A=25°C, unless otherwise specified)

PARAMETER	SYMBOL	RATINGS	UNIT
Supply Voltage	V _{CC}	+45	V
ON/OFF Pin Input Voltage	V _{EN}	-0.3 ~ 40	V
Feedback Pin Voltage	V _{FB}	-0.3 ~ 12	V
Output Voltage to Ground	V _{OUT}	-0.8	V
Operating Supply Voltage	V _{OP}	+4.5 ~ +40	V
Power Dissipation	P _D	Internally Limited	W
Junction Temperature	T _J	+125	°C
Operating Temperature	T _{OPR}	-40~+125	°C
Storage Temperature	T _{STG}	-65 ~ +150	°C

Note: Absolute maximum ratings are those values beyond which the device could be permanently damaged. Absolute maximum ratings are stress ratings only and functional device operation is not implied.

■ THERMAL DATA

PARAMETER	SYMBOL	RATINGS	UNIT
Junction to Ambient	θ _{JA}	60	°C/W
Junction to Case	θ _{JC}	20	°C/W

Note: θ_{JA} is measured with the PCB copper area(need connect to SW pins) of approximately 1.5 in²(Multi-layer).

■ ELECTRICAL CHARACTERISTICS (T_A=25°C, unless otherwise specified, V_{CC}=12V for 3.3V, 5V, adjustable version and V_{CC}=18V for the 12V version. I_{LOAD}=0.2A.)

PARAMETER		SYMBOL	TEST CONDITIONS	MIN	TYP	MAX	UNIT
Quiescent Current		I _Q	V _{FB} =12V force driver off		4	8	mA
Feedback Bias Current	ADJ	I _{FB}	V _{FB} =1.3V		-10	-50	nA
Shutdown Supply Current		I _{SD}	EN pin=5V, V _{CC} =40V		100	200	μA
Oscillator Frequency		f _{OSC}		44	50	56	KHz
Oscillator Frequency of Short Circuit Protect	ADJ	f _{SCP}	V _{FB} <0.5V		25		KHz
	Fixed		V _{OUT} < V _{OUT} *40%		25		KHz
Duty Cycle	MAX	DC	V _{FB} =0V force driver ON		100		%
	MIN	DC	V _{FB} =12V force driver OFF		0		%
Current Limit		I _{CL}	Pear current, No outside circuit V _{FB} =0V force driver on	2.5			A
Load Regulation(ΔV _{OUT} /V _{OUT})		ΔV _{OUT}	I _{OUT} =0.2 ~ 2A		0.6	1.2	%
Saturation Voltage		V _{SAT}	I _{OUT} =2A, No outside circuit V _{FB} =0V force driver on		1.2	1.4	V
SW pin Leakage Current	SW pin=0V	I _{SWL}	No outside circuit V _{FB} =12V force driver off			-200	μA
	SW pin=-0.8V		V _{CC} =40V force driver off		-5		mA
EN pin Logic Input Threshold Voltage	Low	V _{IL}	regulator ON		1.3	0.6	V
	High	V _{IH}	regulator OFF	2.0	1.3		V
EN pin Logic Input Current		I _H	V _{EN} =2.5V (OFF)		-0.1	-10	μA
EN pin Input Current		I _L	V _{EN} =0.5V (ON)		-0.01	-1	μA
Thermal shutdown Temp		TSD			135		°C
Output Feedback Voltage	ADJ	V _{FB}	I _{LOAD} =0.2A, V _{OUT} programmed for 3.3V	1.193	1.23	1.267	V
	3.3V		I _{LOAD} =0.2A	3.20	3.30	3.40	
	5.0V		I _{LOAD} =0.2A	4.85	5.00	5.15	
	12V		I _{LOAD} =0.2A	11.64	12.0	12.36	
Efficiency	ADJ	η	V _{CC} =12V, I _{LOAD} =2A		79		%
	3.3V		V _{CC} =12V, I _{LOAD} =2A		80		
	5.0V		V _{CC} =12V, I _{LOAD} =2A		84		
	12V		V _{CC} =15V, I _{LOAD} =2A		90		

■ TYPICAL APPLICATION CIRCUIT

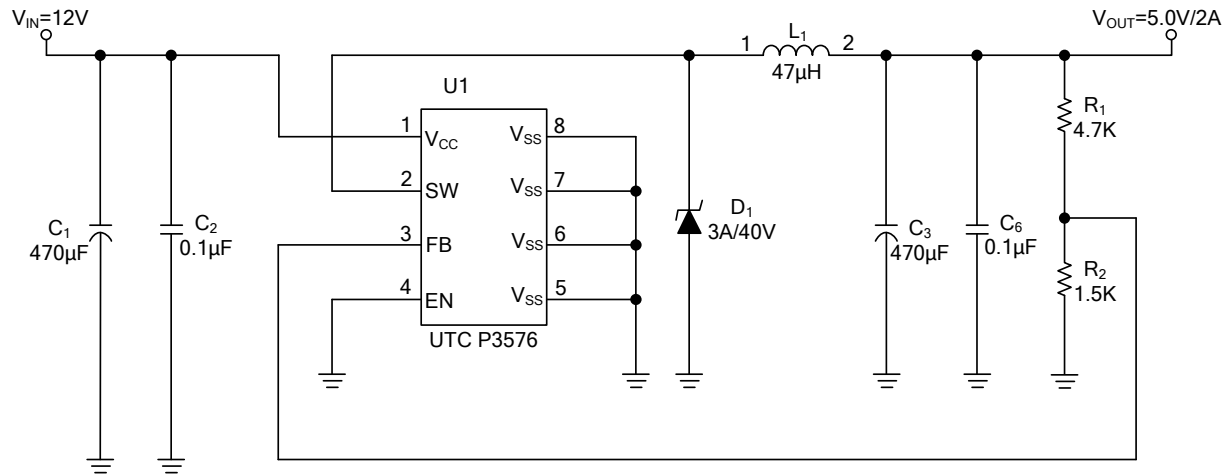

(1) Adjustable Output Voltage Version

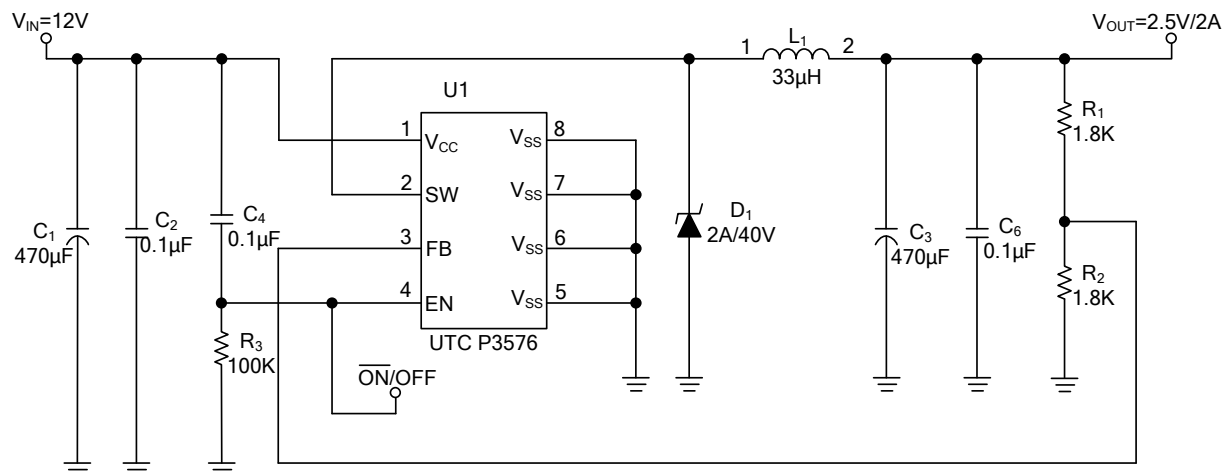

(2) Adjustable Output Voltage Version With Delayed Startup

$$V_{OUT} = V_{FB} \times (1 + R_1/R_2), \quad V_{FB} = 1.23V, \quad R_2 = 0.47K \sim 3K$$

Table 1 Resistor select for output voltage setting

V _{OUT}	R2	R1
5V	1.5K	4.7K
	1.8K	5.6K
3.3V	1.5K	2.5K
	1.8K	3.0K
2.5V	1.8K	1.8K
1.8V	1.8K	0.82K

L1 recommend value (I _{OUT} =2A)				
V _{OUT}	2.5V	3.3V	5V	12V
V _{IN} =12V	33µH	33µH	47µH	NA
V _{IN} =24V	33µH	33µH	47µH	68µH

■ TYPICAL APPLICATION CIRCUIT (Cont.)

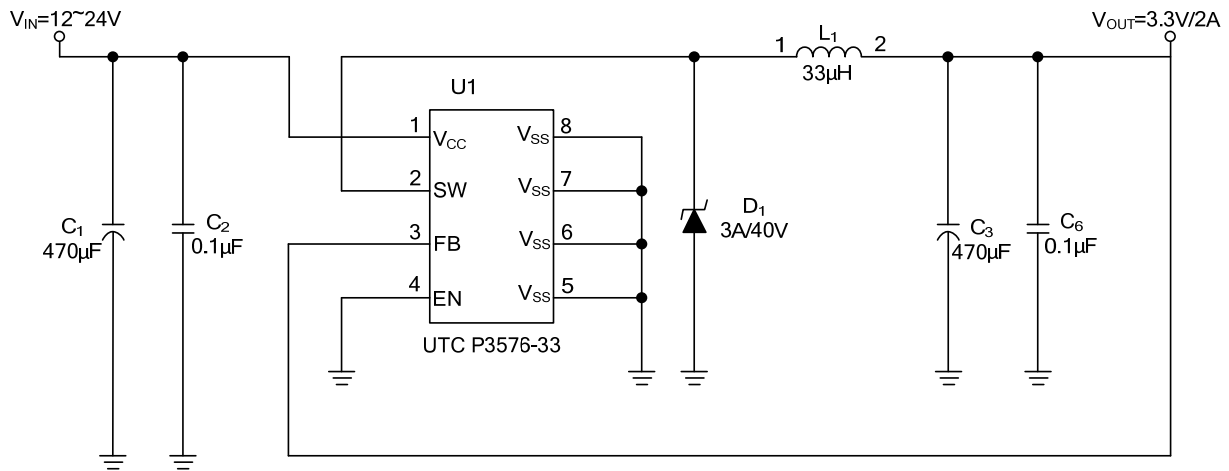

(3) Fixed Output Voltage Version

UTC assumes no responsibility for equipment failures that result from using products at values that exceed, even momentarily, rated values (such as maximum ratings, operating condition ranges, or other parameters) listed in products specifications of any and all UTC products described or contained herein. UTC products are not designed for use in life support appliances, devices or systems where malfunction of these products can be reasonably expected to result in personal injury. Reproduction in whole or in part is prohibited without the prior written consent of the copyright owner. The information presented in this document does not form part of any quotation or contract, is believed to be accurate and reliable and may be changed without notice.