

YELLOW STONE CORP.

Features

- § forward current $\leq 30\text{mA}$
- § Wide viewing angle: 15°
- § Operating Temperature $-30\sim 80^\circ\text{C}$
- § Storage temperature $-40\sim 100^\circ\text{C}$
- § Junction Temperature 110°C
- § ROHS and REACH-compliant
- § Lens Color Code : Water Transparent
- § Lead Frame : Ag Plating Iron Alloy
- § Resin(Mold) : Epoxy
- § Chip material: InGaN
- § Reverse Voltage: 5V
- § Pulsed Forward Current: 100mA
- § Duty 1/10 Pulse Width 0.1ms

Product Identification Code

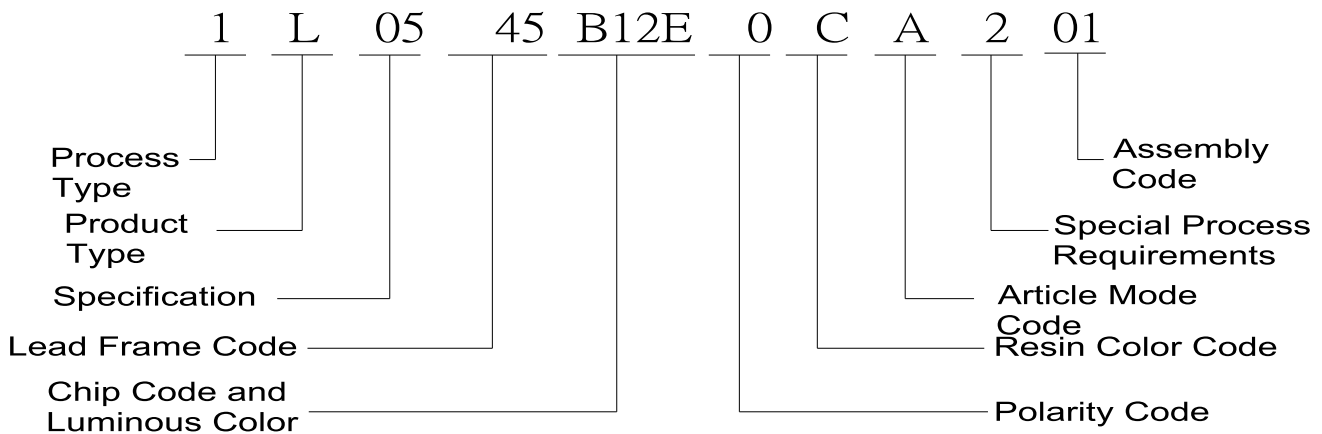

Directive Characteristics ($T_a=25^\circ\text{C}$)

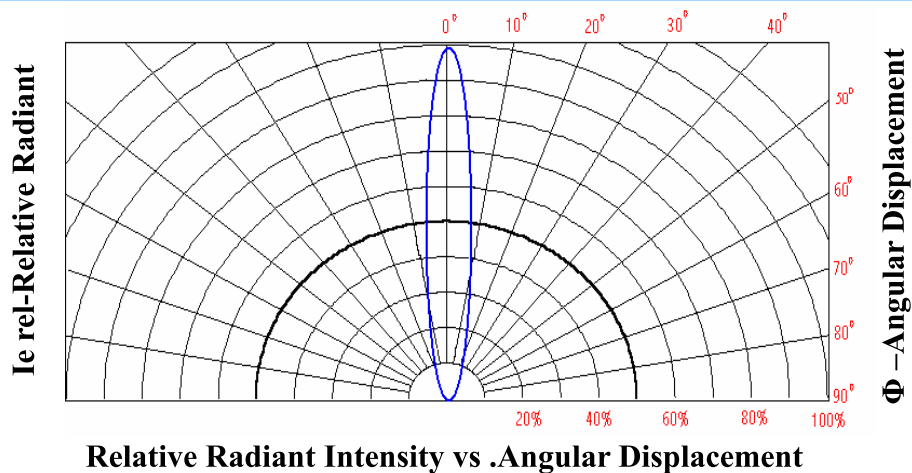

YELLOW STONE CORP.

Electrical-Optical Characteristics (Ta=25°C)

Parameter	Symbol	Value			Unit	Test condition
		Min.	Typ.	Max.		
Forward Voltage	Vf	2.8	3.2	3.8	V	If=20mA
Luminous intensity	Iv	2800	5200		mcd	If=20mA
Wavelength	λd	462.5		472.5	nm	If=20mA
Reverse Current	Ir			10	μ A	Vr=5V
Viewing angle	2 θ 1/2		15		Deg	If=20mA

1.Luminous intensity (IV) \pm 10%, Forward Voltage (VF) \pm 0.1V, Wavelength (λd) \pm 0.5nm

2.IS standard testing

Range of bins

Bin	Bin0	Bin1	Bin2	Bin3	Bin4	Bin5	Bin6
IV	1-3	3-6	6-9	9-13	13-20	20-30	30-45
Bin	Bin7	Bin8	Bin9	Bin10	Bin11	Bin12	Bin13
IV	45-70	70-90	90-120	120-160	160-210	210-270	270-350
Bin	Bin14	Bin15	Bin16	Bin17	Bin18	Bin19	Bin20
IV	350-460	460-600	600-780	780-1000	1000-1300	1300-1700	1700-2200
Bin	Bin21	Bin22	Bin23	Bin24	Bin25	Bin26	Bin27
IV	2200-2800	2800-3700	3700-4900	4900-6300	6300-8200	8200-10600	10600-13800
Bin	Bin28	Bin29	Bin30	Bin31	Bin32	Bin33	
IV	13800-18000	18000-23400	23400-30400	30400-39500	39500-51400	51400-66800	
Bin	D	E					
λd	462.5-467.5	467.5-472.5					

**IV Unit: mcd. λd Unit: nm

YELLOW STONE CORP.

Optical Characteristics

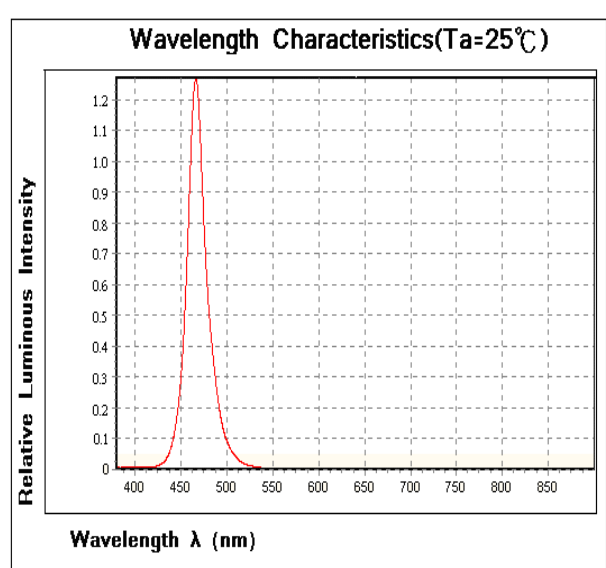
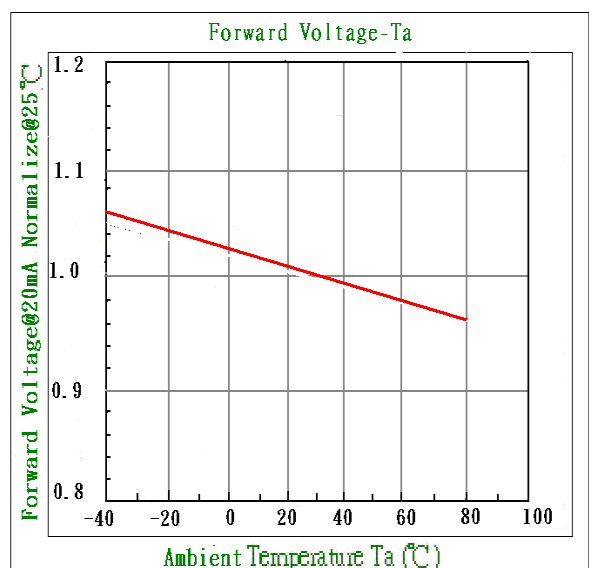
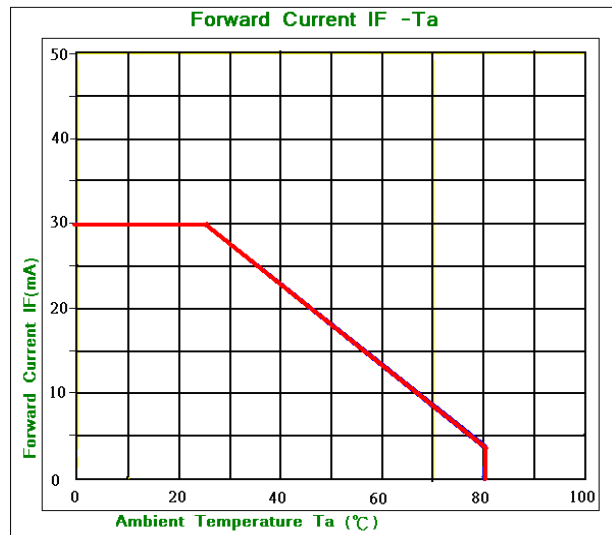
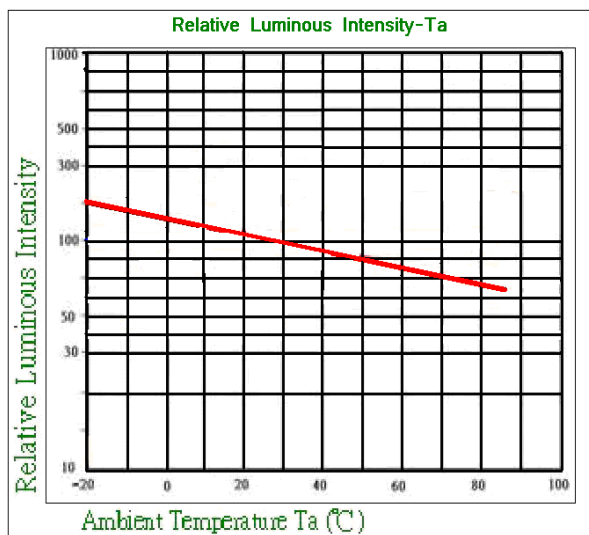
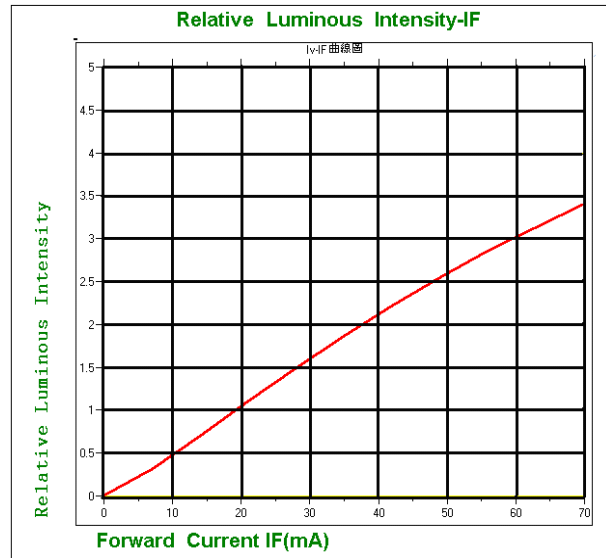
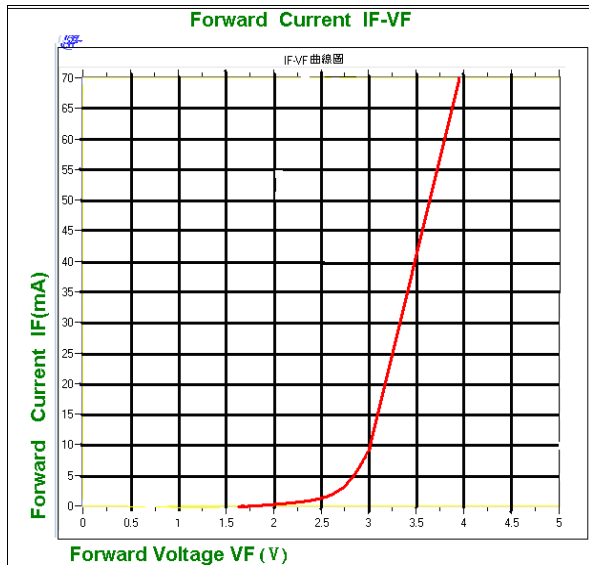

YELLOW STONE CORP.

Outline Dimensions

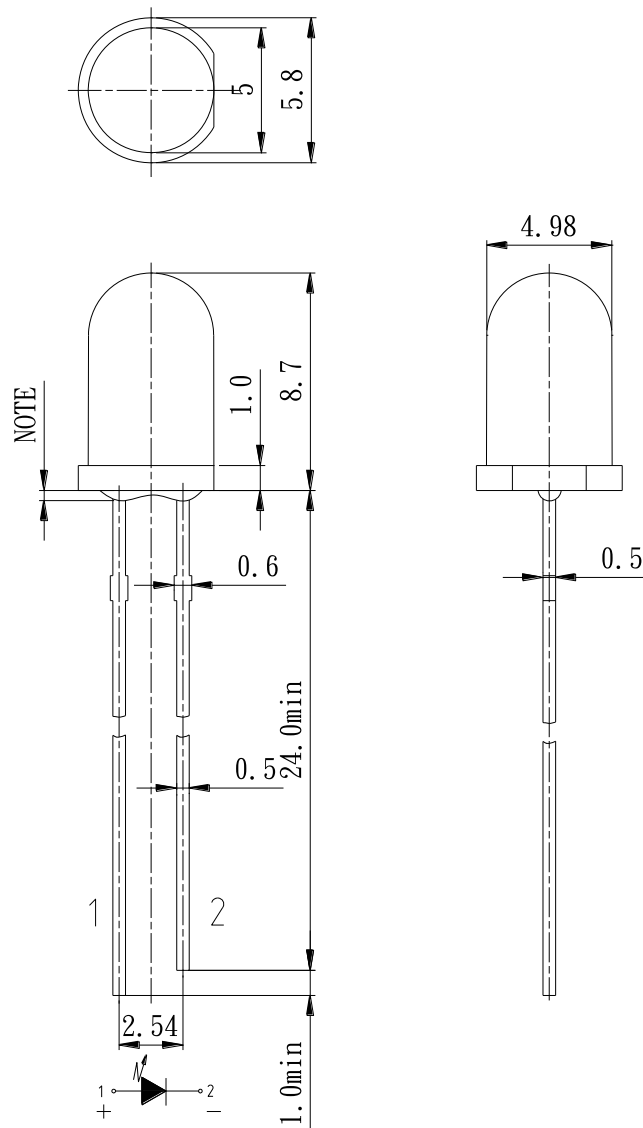

單位 (Units)	圖面未注差 (Encapsulation tolerance)	膠體外觀公差 (Encapsulation tolerance)	膠體伸出尺寸 (NOTE3) (Dimensions of protruded resin flange)
mm	±0.3	±0.25	Max 1.0