

## **SPECIFICATION**

### ACROSS-THE-LINE AND INTERFERENCE SUPPRESSION CAPACITORS CLASS X2 --- CTX

---

1. REFERENCE STANDARDS: UL 60384-14, CSA C22.2  
USED FOR ACROSS-THE LINE CAPACITORS, ANTENNA-COUPLING AND  
LINE-BY-PASS COMPONENTS.  
ENEC            EN 60384-14 (2013)  
CQC            GB/T6346.14-2015  
KC Mark        K60384-14  
USED FOR RADIO INTERFERENCE SUPPRESSION CAPACITORS.
2. RATED VOLTAGE : 310 VAC, 50 ~ 60 Hz
3. CAPACITANCE RANGE : 0.0047  $\mu$ F ~ 10 $\mu$ F
4. CAPACITANCE TOLERANCE : J ( $\pm$ 5% ), K ( $\pm$ 10% ), M ( $\pm$ 20% )
5. DIELECTRIC : METALLIZED POLYPROPYLENE FILM
6. DISSIPATION FACTOR TAN  $\delta$  : LESS THAN 0.1% AT 1K Hz/20  $^{\circ}$ C  
VOLTAGE 1.0 VAC (CAPACITANCE : 1K Hz/20  $^{\circ}$ C, VOLTAGE 1.0 VAC)
7. INSULATION RESISTANCE : BETWEEN TERMINALS  
(1) LESS THAN OR EQUAL TO 0.33  $\mu$ F  $\leq 10 \times 10$   
(2) GREATER THAN 0.33  $\mu$ F  $\leq 10 \times \mu$ F  
MEASURED AT 100  $\pm$  15 VDC, 60 Sec./20  $^{\circ}$ C
8. WITHSTAND VOLTAGE :
  - a) BETWEEN TERMINALS.... 1333VDC FOR 60 Sec. OR 1500V.DC FOR 1Sec.  
CUT-OFF CURRENT : 10mA
  - b) BETWEEN TERMINALS AND CASE....2120 VAC 60 Hz FOR 60 Sec.
9. CLIMATIC CATEGORY : IN ACCORDANCE WITH DIN 40040 GLF  
G (MINIMUM LIMIT TEMPERATURE) = - 40  $^{\circ}$ C  
L (MAXIMUM LIMIT TEMPERATURE) = + 110  $^{\circ}$ C  
F (HUMIDITY CATEGORY) = AVERAGE RELATIVE HUMIDITY  $\leq$  75  
95% FOR 30 DAYS PER YEAR CONTINUOUSLY  
85% FOR THE REMAINING DAYS OCCASIONALLY

## **SPECIFICATION**

10. DRY HEAT RESISTANCE :

IN ACCORDANCE WITH DIN 40046 SHEET 1 OR IEC 68-2-2 TEST BA. CONDITIONS

TEST TEMPERATURE :  $110 \pm 2$  °C

TEST DURATION : 16 HOURS

TEST CRITERIA :

(1) APPEARANCE : NO VISIBLE DAMAGE AND NO LEAKAGE

(2) WITHSTAND VOLTAGE : RATED WITHSTAND VOLTAGE 60 Sec.

(3) CAPACITANCE CHANGE : ~~≤ 10~~ OF THE INITIAL VALUE

(4) INSULATION RESISTANCE : ~~≥ 60~~ INITIAL SPECIFIED VALUE

11. COLD RESISTANCE :

IN ACCORDANCE WITH DIN 40046 SHEET 1 OR IEC 68-2-1 TEST BA. CONDITIONS

TEST TEMPERATURE :  $-40 \pm 2$  °C

TEST DURATION : 2 HOURS

TEST CRITERIA :

(1) APPEARANCE : NO VISIBLE DAMAGE

(2) WITHSTAND VOLTAGE : RATED WITHSTAND VOLTAGE 60 Sec.

(3) CAPACITANCE CHANGE : ~~≤ 10~~ OF THE INITIAL VALUE

12. HUMIDITY TEST CONDITIONS :

TEST TEMPERATURE : 40 °C  $\pm 2$  °C

RELATIVE HUMIDITY : 90 – 95 %

TEST DURATION : 500 HOURS

TEST CRITERIA :

(1) WITHSTAND VOLTAGE : RATED WITHSTAND VOLTAGE 60 Sec.

(2) CAPACITANCE DRIFT : ~~≤ 10~~ OF THE INITIAL VALUE

(3) DISSIPATION FACTOR : ~~≥ 20~~ INITIAL SPECIFIED VALUE

(4) INSULATION RESISTANCE : ~~≥ 60~~ INITIAL SPECIFIED VALUE

## **SPECIFICATION**

13. LIFE TEST CONDITIONS :

TEST TEMPERATURE : 110 °C ±3

TEST VOLTAGE : 388 VAC AND 1,000 VAC/60 HZ FOR A PERIOD OF 0.1 Sec. ONCE EACH HOUR

TEST DURATION : 1,000 HOURS

TEST CRITERIA :

(1) APPEARANCE : NO VISIBLE DAMAGE AND NO LEAKAGE

(2) WITHSTAND VOLTAGE : RATED WITHSTAND VOLTAGE 60 Sec.

(3) CAPACITANCE DRIFT : ~~± 5 %~~ OF THE INITIAL VALUE

(4) DISSIPATION FACTOR : ~~≤ 0.05~~ OF INCREASED VALUE

(5) INSULATION RESISTANCE : ~~≥ 0.5~~ SPECIFIED VALUE

14. SOLDERABILITY CONDITIONS :

SOLDER BATH TEMPERATURE & MATERIAL :

230 ± 5 °C ~~60~~ TIN (Sn) + 40 % OF LEAD (Pb)

SOLDER BATH TEMPERATURE & MATERIAL :

270 ± 5 °C ~~60~~ TIN (Sn) + 0.04 % OF SILVER (Ag)

SOLDER TIME : 3 ± 0.5 Sec. TEST CRITERIA : 75% OF THE SURFACE TINNING

15. SOLDERING HEAT RESISTANCE :

IN ACCORDANCE WITH DIN 40046 SHEET 18 OR IEC 68-2-20 TEST TA.1 & TB.1 CONDITIONS

SOLDER BATH TEMPERATURE : 260 ± 5 °C

SOLDER TIME : 4 Sec.

CAPACITANCE BODY MAY LIE ON PRINTING CIRCUIT BOARD

TEST CRITERIA :

(1) APPEARANCE : NO DAMAGE AND GOOD TINNING

(2) CAPACITANCE CHANGE : ~~≤ 0.5~~ OF THE INITIAL VALUE

16. VIBRATION RESISTANCE :

IN ACCORDANCE WITH DIN 40046 SHEET 8 OR IEC 68-2-6 TEST FC CONDITIONS

FREQUENCY RANGE : 10 - 55 HZ

DISPLACEMENT AMPLITUDE : 0.75 mm

CONFORMING TO MAX. : 10 g

## **SPECIFICATION**

TEST DURATION : 6 HOURS

TEST CRITERIA :

(1) APPEARANCE : NO VISIBLE DAMAGE

(2) CAPACITANCE CHANGE :  $\leq 0.1$  OF THE INITIAL VALUE

### 17. TENSILE STRENGTH OF TERMINALS

IN ACCORDANCE WITH DIN 40046 SHEET 19 OR IEC 68-2-21 TEST UA.1

CONDITIONS

TERMINAL	LOAD FORCE	HOLDING TIMES
DIA. (mm)	KG (N)	Sec.
$\leq 0.5$	0.5 (5)	10
$> 0.5$ TO $< 0.8$	1.0 (10)	10
$> 0.8$	2.0 (20)	20

TEST CRITERIA : NO WIRE BREAKAGE AND NO DAMAGE OF CAPACITOR

### 18. BENDING OF TERMINALS

IN ACCORDANCE WITH DIN 40046 SHEET 19 OR IEC 68-2-21 TEST UB. CONDITIONS

LOAD FORCE : 0.5 KG (5N)

BENDING TIME : TWO CONSECUTIVE BENDS (4 x 90 °C)

TEST CRITERIA : NO WIRE BREAKAGE AND DAMAGE OF CAPACITOR

### 19. APPROVED BY :

UL · CUL FILE NO. E193049 (0.0047uF/310V~10uF/310V)

ENEC Licence No. ENEC-01396-A1-M2 (0.0047uF/310V~52uF/310V)

KC MARK HU03009-10004B (0.1uF 275V.AC)

HU03009-10006B (0.15uF 0.22uF 0.33uF 275V.AC)

HU03009-10005B (0.47uF 0.68uF 1.0uF 275V.AC)

CQC CQC17001161572 (0.0047~52uF 310V.AC)

### 20. MARKING :

CAPACITORS ARE MARKED WITH TYPE IDENTIFICATION CAPACITANCE, CAPACITANCE TOLERANCE, RATED VOLTAGE, TEMPERATURE RANGE, NAME OF MANUFACTURE, DATE OF MANUFACTURE AND APPROVED CERTIFICATION MARKS.

Marking Example

0.022 ~ 0.1 uF

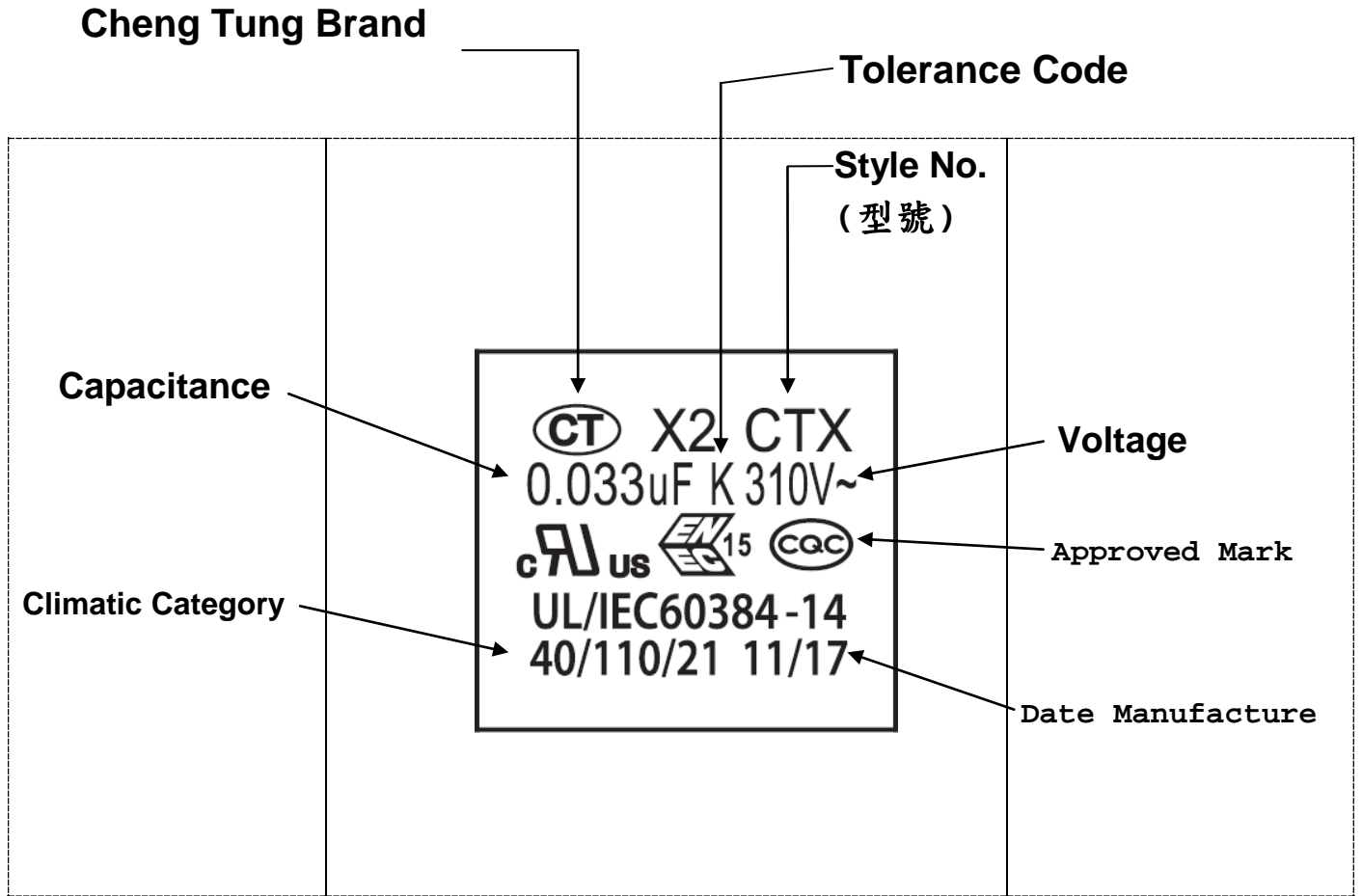

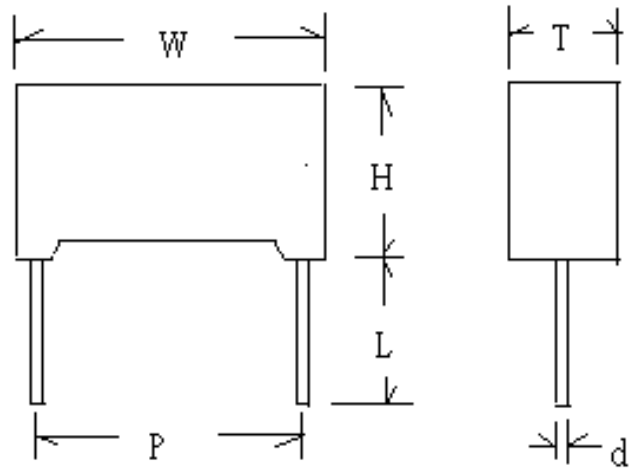

P/N	Cap.	Voltage	Dimensions in mm					
	uF	VAC	$W \pm 0.5$	$H \pm 0.5$	$T \pm 0.5$	$P \pm 0.5$	Lmin	$d \pm 0.05$
CTX224K310VP10X	0.22	310	18	12	6	15	<b>20</b>	0.8
CTX474K310VP10X	0.47	310	18	14.5	8.5	15	<b>20</b>	0.8
CTX335K310VP275X	3.3	310	31.5	25	14	27.5	<b>20</b>	0.8

# Catalogue Number System

