

Thick Film Chip Resistor
Thick Film Chip Resistor



■ Scope

- This specification applies to all sizes of rectangular-type fixed chip resistors with Ruthenium-base as material.

■ Features

- Small size and light weight
- Highly reliable multilayer electrode construction
- Compatible with all soldering process
- Long side terminations

■ Construction

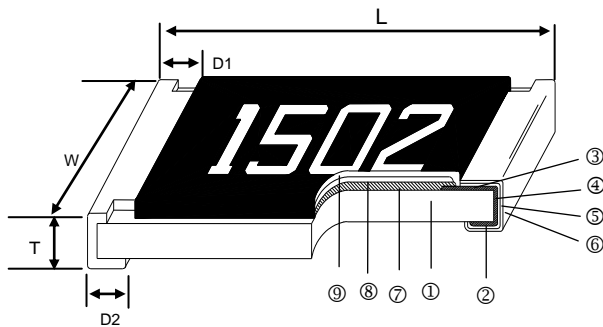

■ Applications

- Telecommunication Equipments
- Radio and Tape Recorders, TV Tuners
- Digital Cameras, Watches, Pocket Calculators
- Computers, Instruments
- Medical Equipment

① Alumina Substrate	④ Edge Electrode	⑦ Resistor Layer
② Bottom Electrode	⑤ Barrier Layer	⑧ Primary Overcoat
③ Top Electrode	⑥ External Electrode	⑨ Secondary Overcoat

■ Dimensions

Type	Size (Inch)	L (mm)	W (mm)	T (mm)	D1 (mm)	D2 (mm)	Weight (g) (1000pcs)
CR-E5	01005	0.40±0.02	0.20±0.02	0.13±0.02	0.10±0.03	0.10±0.03	0.037
CR-01	0201	0.60±0.03	0.30±0.03	0.23±0.03	0.15±0.05	0.15±0.05	0.150
CR-02	0402	1.00±0.05	0.50±0.05	0.35±0.05	0.20±0.10	0.20±0.10	0.620
CR-03	0603	1.60±0.10	0.80±0.10	0.45±0.10	0.30±0.20	0.30±0.20	2.042
CR-05	0805	2.00±0.10	1.25±0.10	0.50±0.10	0.35±0.20	0.40±0.20	4.368
CR-06	1206	3.10±0.10	1.55±0.10	0.55±0.10	0.50±0.25	0.50±0.20	8.947
CR-10	1210	3.10±0.10	2.60±0.15	0.55±0.10	0.50±0.25	0.50±0.20	15.959
CR-0A	2010	5.00±0.10	2.50±0.15	0.55±0.10	0.60±0.25	0.50±0.20	24.241
CR-12	2512	6.35±0.10	3.10±0.15	0.55±0.10	0.60±0.25	0.50±0.20	39.448
CR-25	1225	3.20±0.15	6.45±0.15	0.90±0.15	0.60±0.30	0.80±0.25	64.88
CR-62	0612	1.55±0.10	3.10±0.15	0.55±0.10	0.25±0.15	0.35±0.15	9.31

Part Numbering

Part Number : CR-03FL7---10R

Part Number : CR-03JL7----0R

CR-	03	F	L	7	- - - 1 0 R
CR-	03	J	L	7	- - - - 0 R
Product Type	Dimensions	Resistance Tolerance	Function Code	Packaging Code	Resistance
CR-	E5: 01005 01: 0201 02: 0402 03: 0603 05: 0805 06: 1206 10: 1210 0A: 2010 12: 2512 25: 1225 62: 0612	B: ±0.1% C: ±0.25% D: ±0.5% F: ±1% J: ±5%	L: Standard & High Precision E: TC50 P: High Power H: Ultra High Power	0: 7" Reel 15Kpcs 2: 7" Reel 2Kpcs 4: 7" Reel 4Kpcs 5: 7" Reel 20Kpcs 6: 7" Reel 10Kpcs 7: 7" Reel 5Kpcs 9: 10" Reel 8Kpcs A: 10" Reel 10Kpcs B: 10" Reel 20Kpcs C: 13" Reel 40Kpcs D: 13" Reel 20Kpcs	--- 1R2: 1.2Ω --- 3K3: 3.3KΩ --- 10K: 10KΩ -- 100K: 100KΩ “-“ to fill up 6 spaces

Standard Electrical Specifications

Item Type	Power Rating at 70°C Jumper Rated Current	Operating Temp. Range	Max. Operating Voltage	Max. Overload Voltage	Resistance Range		TCR (PPM/°C)
					±1%(E24、E96)	±5%(E24)	
CR-E5 (01005)	1/32W	-55 ~ +125°C	15V	30V	10Ω - 1MΩ		±300
	Jumper: 0.5A				-	0Ω (<50mΩ)	-
CR-01 (0201)	1/20W	-55 ~ +125°C	25V	50V	1Ω - 10MΩ		±200
	Jumper: 1A				-	0Ω (<50mΩ)	-
CR-02 (0402)	1/16W	-55 ~ +155°C	50V	100V	1Ω - 9.76Ω 10Ω - 1MΩ 1.02MΩ - 20MΩ 20.5MΩ - 100MΩ		±200 ±100 ±200 ±400
	Jumper: 1A				-	0Ω (<50mΩ)	-
CR-03 (0603)	1/10W	-55 ~ +155°C	75V	150V	1Ω - 9.76Ω 10Ω - 1MΩ 1.02MΩ - 20MΩ 20.5MΩ - 100MΩ		±200 ±100 ±200 ±400
	Jumper: 1A				-	0Ω (<50mΩ)	-
CR-05 (0805)	1/8W	-55 ~ +155°C	150V	300V	1Ω - 9.76Ω 10Ω - 1MΩ 1.02MΩ - 20MΩ 20.5MΩ - 100MΩ		±200 ±100 ±200 ±400
	Jumper: 2A				-	0Ω (<50mΩ)	-
CR-06 (1206)	1/4W	-55 ~ +155°C	200V	400V	1Ω - 9.76Ω 10Ω - 1MΩ 1.02MΩ - 20MΩ 20.5MΩ - 100MΩ		±200 ±100 ±200 ±400
	Jumper: 2A				-	0Ω (<50mΩ)	-
CR-10 (1210)	1/3W	-55 ~ +155°C	200V	400V	1Ω - 9.76Ω 10Ω - 1MΩ 1.02MΩ - 20MΩ 20.5MΩ - 39MΩ		±200 ±100 ±200 ±400
	Jumper: 2.5A				-	0Ω (<50mΩ)	-

Item Type	Power Rating at 70°C Jumper Rated Current	Operating Temp. Range	Max. Operating Voltage	Max. Overload Voltage	Resistance Range		TCR (PPM/°C)
					±1%(E24、E96)	±5%(E24)	
CR-0A (2010)	3/4W	-55 ~ +155°C	200V	400V	1Ω - 9.76Ω 10Ω - 1MΩ 1.02MΩ - 20MΩ 20.5MΩ - 100MΩ		±200 ±100 ±200 ±400
	Jumper: 3.5A				-	0Ω (<50mΩ)	-
CR-12 (2512)	1W	-55 ~ +155°C	250V	500V	1Ω - 9.76Ω 10Ω - 1MΩ 1.02MΩ - 20MΩ 20.5MΩ - 100MΩ		±200 ±100 ±200 ±400
	Jumper: 4A				-	0Ω (<50mΩ)	-
CR-25 (1225)	2W	-55 ~ +155°C	200V	400V	10Ω - 20KΩ		±100
	Jumper: 10A				-	0Ω (<20mΩ)	-
CR-62 (0612)	0.75W	-55 ~ +155°C	200V	400V	1Ω-1MΩ		±100

High Precision Electrical Specifications

Item Type	Power Rating at 70°C	Operating Temp. Range	Max. Operating Voltage	Max. Overload Voltage	Resistance Range (E24、E96)			TCR (PPM/°C)
					±0.1%	±0.25%	±0.5%	
CR-02 (0402)	1/16W	-55 ~ +155°C	50V	100V	-	10Ω - 1MΩ		±100
CR-03 (0603)	1/10W		75V	150V	-	1.02M - 10MΩ		±200
CR-05 (0805)	1/8W		150V	300V	10Ω - 1MΩ			±100
					-	1.02M - 10MΩ		±200
CR-06 (1206)	1/4W		200V	400V	10Ω - 1MΩ			±100
					-	1.02M - 10MΩ		±200
CR-10 (1210)	1/3W		200V	400V	-	10Ω - 1MΩ		±100
CR-0A (2010)	3/4W		200V	400V	10Ω - 1MΩ			±100
		-			1.02M - 10MΩ		±200	
CR-12 (2512)	1W	250V	500V	10Ω - 1MΩ			±100	
				-	1.02M - 10MΩ		±200	

TC50 Electrical Specifications

Item Type	Power Rating at 70°C	Operating Temp. Range	Max. Operating Voltage	Max. Overload Voltage	Resistance Range (E24、E96)				TCR (PPM/°C)
					±0.1%	±0.25%	±0.5%	±1%	
CR-02 (0402)	1/16W	-55 ~ +155°C	50V	100V	-		100Ω - 1MΩ		±50
CR-03 (0603)	1/10W		75V	150V	10Ω - 1MΩ	10Ω - 10MΩ			
CR-05 (0805)	1/8W		150V	300V					
CR-06 (1206)	1/4W		200V	400V					
CR-10 (1210)	1/3W		200V	400V					
CR-0A (2010)	3/4W		200V	400V					
CR-12 (2512)	1W		250V	500V					

High Power & Ultra High Power Rating Electrical Specifications

Type	Item	Power Rating at 70°C	Operating Temp. Range	Max. Operating Voltage	Max. Overload Voltage	Resistance Range		TCR (PPM/°C)
						±1% (E24 · E96)	±5% (E24)	
CR-02 (0402)	1/8W	Jumper: 1.5A	-55 ~ +155°C	50V	100V	1Ω - 9.76Ω 10Ω - 1MΩ -	1Ω - 9.76Ω 10Ω - 1MΩ 0Ω (<20mΩ)	±200 ±100 -
	CR-03 (0603)							
CR-05 (0805)	1/3W	Jumper: 2.5A		150V	300V			
	CR-06 (1206)			1/3 *1/2W	Jumper: 3.5A			
CR-10 (1210)	1/2 *3/4W	Jumper: 5A		200V	400V			
	CR-0A (2010)			1W	Jumper: 6A			
CR-12 (2512)	2W	Jumper: 7A		250V	500V			

*: Ultra High Power

Operating Voltage= $\sqrt{P \cdot R}$ or Max. Operating Voltage listed above, whichever is lower.

Overload Voltage= $2.5 \cdot \sqrt{P \cdot R}$ or Max. Overload Voltage listed above, whichever is lower.

■ Viking is capable of manufacturing the optional spec based on customer's requirement.

Soldering Condition

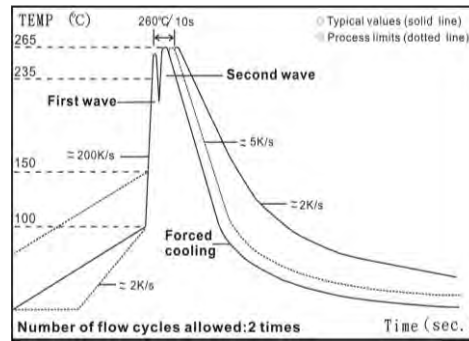
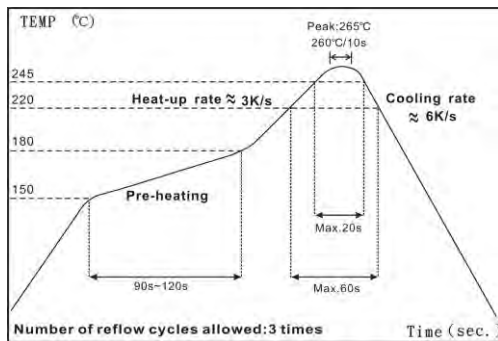

IR Reflow Soldering

Wave Soldering (Flow Soldering)

- (1) Time of IR reflow soldering at maximum temperature point 260°C : 10s
- (2) Time of wave soldering at maximum temperature point 260°C : 10s
- (3) Time of soldering iron at maximum temperature point 410°C : 5s

Derating Curve

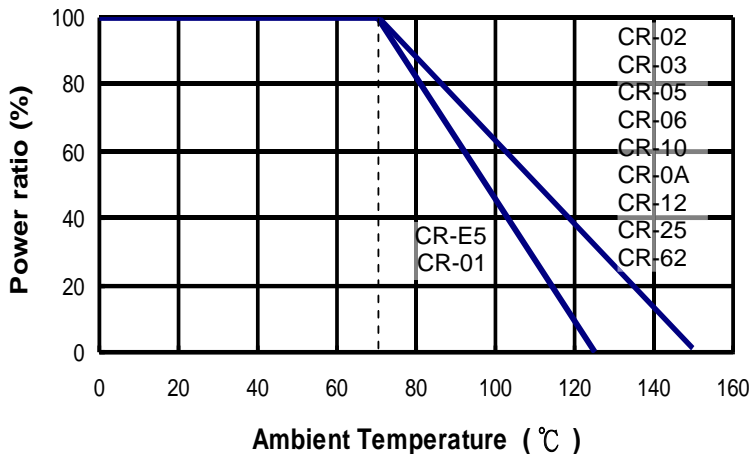

Environmental Characteristics

Item	Requirement			Test Method
	±1% and Below	±5%	Jumper	
Temperature Coefficient of Resistance (T.C.R.)	As Spec.			JIS-C-5201-1 4.8 IEC-60115-1 4.8 At 25°C/-55°C and 25°C/+125°C, 25°C is the reference temperature
Short Time Overload	±(1.0%+0.05Ω)	±(2.0%+0.05Ω)	<50mΩ	JIS-C-5201-1 4.13 IEC-60115-1 4.13 RCWV*2.5 or Max. Overload Voltage whichever is lower for 5 seconds, 2 seconds for high power series
Insulation Resistance	≥10G			JIS-C-5201-1 4.6 IEC-60115-1 4.6 Max. Overload Voltage for 1 minute
Endurance	±(1.0%+0.10Ω)	±(2.0%+0.10Ω)	<100mΩ	JIS-C-5201-1 4.25 IEC-60115-1 4.25.1 70±2°C, RCWV for 1000 hrs with 1.5 hrs "ON" and 0.5 hr "OFF"
Damp Heat with Load	±(1.0%+0.10Ω)	±(2.0%+0.10Ω)	<100mΩ	JIS-C-5201-1 4.24 IEC-60115-1 4.24 40±2°C, 90~95% R.H., RCWV for 1000 hrs with 1.5 hrs "ON" and 0.5 hr "OFF"
Dry Heat	±(1.0%+0.05Ω)	±(1.5%+0.10Ω)	<50mΩ	JIS-C-5201-1 4.23 IEC-60115-1 4.23.2 at +125/+155°C for 1000 hrs
Bending Strength	±(1.0%+0.05Ω)	±(1.0%+0.05Ω)	<50mΩ	JIS-C-5201-1 4.33 IEC-60115-1 4.33 Bending once for 5 seconds 2010, 2512 sizes: 2mm Other sizes: 3mm
Solderability	95% min. coverage			JIS-C-5201-1 4.17 IEC-60115-1 4.17 245±5°C for 3 seconds
Resistance to Soldering Heat	±(0.5%+0.05Ω)	±(1.0%+0.05Ω)	<50mΩ	JIS-C-5201-1 4.18 IEC-60115-1 4.18 260±5°C for 10 seconds
Voltage Proof	No breakdown or flashover			JIS-C-5201-1 4.7 IEC-60115-1 4.7 1.42 times Max. Operating Voltage for 1 minute
Leaching	Individual leaching area ≤5% Total leaching area ≤ 10%			JIS-C-5201-1 4.18 IEC-60068-2-58 8.2.1 260±5°C for 30 seconds
Rapid Change of Temperature	±(0.5%+0.05Ω)	±(1.0%+0.05Ω)	<50mΩ	JIS-C-5201-1 4.19 IEC-60115-1 4.19 -55°C to +125/+155°C, 5 cycles

RCWV(Rated Continuous Working Voltage)=√(P*R) or Max. Operating Voltage whichever is lower.

Storage Temperature: 15~28°C; Humidity < 80%RH

Thick Film Chip Resistor

■ Packaging

Reel Specifications & Packaging Quantity

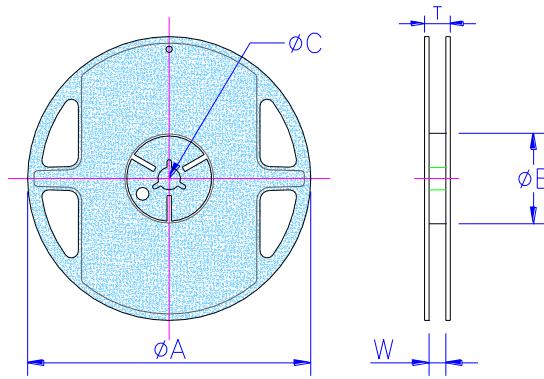

Type	Packaging Quantity	Tape Width	Reel Diameter	ΦA (mm)	ΦB (mm)	ΦC (mm)	W (mm)	T (mm)	
CR-E5	Paper	10K	8mm	7 inch	178.5±1.5	60 ^{+1/-0}	13.0±0.2	9.0±0.5	12.5±0.5
		20K	8mm	7 inch	178.5±1.5	60 ^{+1/-0}	13.0±0.2	9.0±0.5	12.5±0.5
CR-01	Paper	15K	8mm	7 inch	178.5±1.5	60 ^{+1/-0}	13.0±0.2	9.0±0.5	12.5±0.5
CR-01 CR-02	Paper	10K	8mm	7 inch	178.5±1.5	60 ^{+1/-0}	13.0±0.2	9.0±0.5	12.5±0.5
		20K	8mm	10 inch	254±1.0	100±0.5	13.0±0.2	9.5±0.5	13.5±0.5
		40K	8mm	13 inch	330±1.0	100±0.5	13.0±0.2	9.5±0.5	13.5±0.5
CR-03 CR-05 CR-06 CR-10	Paper	5K	8mm	7 inch	178.5±1.5	60 ^{+1/-0}	13.0±0.2	9.0±0.5	12.5±0.5
		10K	8mm	10 inch	254±1.0	100±0.5	13.0±0.2	9.5±0.5	13.5±0.5
		20K	8mm	13 inch	330±1.0	100±0.5	13.0±0.2	9.5±0.5	13.5±0.5
CR-0A CR-12	Embossed	4K	12mm	7 inch	178.5±1.5	60 ^{+1/-0}	13.0±0.5	13.0±0.5	15.5±0.5
		8K	12mm	10 inch	250±1.0	62±0.5	13.0±0.5	12.5±0.5	16.5±0.5
CR-25	Embossed	2K	12mm	7 inch	178.5±1.5	60 ^{+1/-0}	13.0±0.5	13.0±0.5	15.5±0.5
CR-62	Paper	5K	8mm	7 inch	178.5±1.5	60 ^{+1/-0}	13.0±0.2	9.0±0.5	12.5±0.5

Paper Tape Specifications

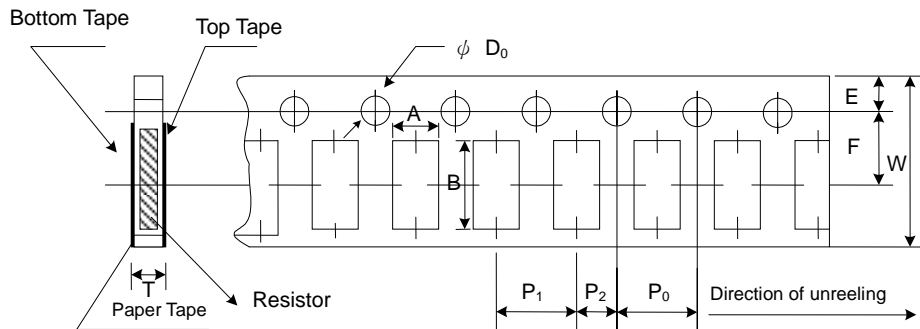

Type	A (mm)	B (mm)	W (mm)	E (mm)	F (mm)	P ₀ (mm)	P ₁ (mm)	P ₂ (mm)	ΦD ₀ (mm)	T (mm)
CR-E5	0.24±0.05	0.45±0.05	8.0±0.20	1.75±0.10	3.50±0.05	4.00±0.10	2.00±0.05	2.00±0.05	1.50+0.1,-0	0.40±0.10
CR-01	0.38±0.05	0.68±0.05	8.0±0.20	1.75±0.10	3.50±0.05	4.00±0.10	2.00±0.05	2.00±0.05	1.50+0.1,-0	0.42±0.20
CR-02	0.65±0.10	1.15±0.10	8.0±0.20	1.75±0.10	3.50±0.05	4.00±0.10	2.00±0.05	2.00±0.05	1.50+0.1,-0	0.45±0.10
CR-03	1.10±0.10	1.90±0.10	8.0±0.20	1.75±0.10	3.50±0.05	4.00±0.10	4.00±0.05	2.00±0.05	1.50+0.1,-0	0.70±0.10
CR-05	1.60±0.10	2.40±0.20	8.0±0.20	1.75±0.10	3.50±0.05	4.00±0.10	4.00±0.05	2.00±0.05	1.50+0.1,-0	0.85±0.10
CR-06	1.90±0.10	3.50±0.20	8.0±0.20	1.75±0.10	3.50±0.05	4.00±0.10	4.00±0.05	2.00±0.05	1.50+0.1,-0	0.85±0.10
CR-10	2.90±0.10	3.50±0.20	8.0±0.20	1.75±0.10	3.50±0.05	4.00±0.10	4.00±0.05	2.00±0.05	1.50+0.1,-0	0.85±0.10
CR-62	1.90±0.10	3.50±0.20	8.0±0.20	1.75±0.10	3.50±0.05	4.00±0.10	4.00±0.05	2.00±0.05	1.50+0.1,-0	0.85±0.10

Thick Film Chip Resistor

Embossed Plastic Tape Specifications

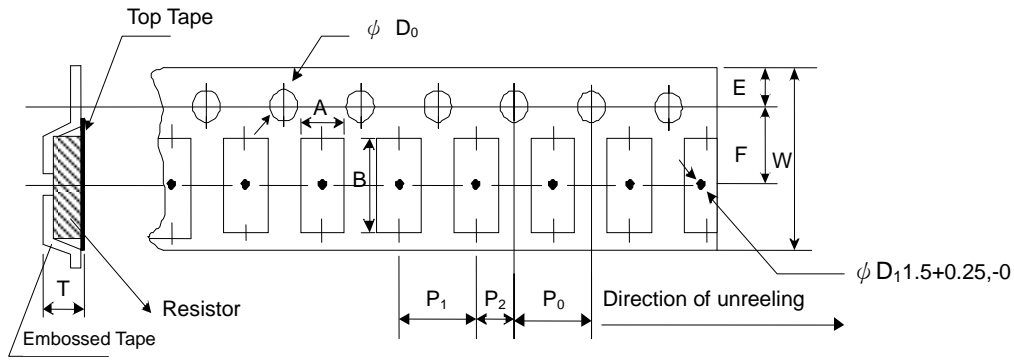

Type	A (mm)	B (mm)	W (mm)	E (mm)	F (mm)	P ₀ (mm)	P ₁ (mm)	P ₂ (mm)	ΦD ₀ (mm)	T (mm)
CR-0A	2.8±0.10	5.5±0.10	12.0±0.30	1.75±0.10	5.5±0.05	4.00±0.10	4.00±0.10	2.00±0.05	1.50+0.1, -0	1.2 ⁺⁰
CR-12	3.5±0.10	6.7±0.10	12.0±0.30	1.75±0.10	5.5±0.05	4.00±0.10	4.00±0.10	2.00±0.05	1.50+0.1, -0	1.2 ⁺⁰
CR-25	3.38±0.10	6.68±0.10	12.0±0.30	1.75±0.10	5.5±0.10	4.00±0.10	4.00±0.10	2.00±0.05	1.55+0.05	1.45±0.20

Recommend Land Pattern

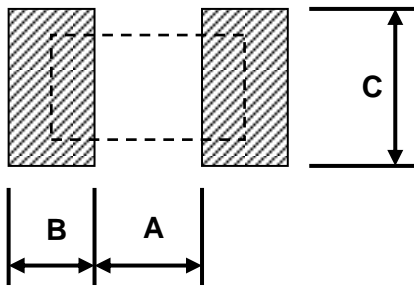

Type	A (mm)	B (mm)	C (mm)
CR-E5	0.14	0.18	0.25
CR-01	0.30	0.25	0.30
CR-02	0.50	0.45	0.60
CR-03	0.90	0.60	0.90
CR-05	1.20	0.70	1.30
CR-06	2.00	0.90	1.60
CR-10	2.00	0.90	2.80
CR-0A	3.80	0.90	2.80
CR-12	4.90	1.60	3.50
CR-25	1.20	2.00	7.00
CR-62	0.70	1.20	3.20

Marking

No Marking for 01005, 0201 and 0402

Jumper for all: Letter "0"

1% for 0805/1206/1210/2010/2512/1225/0612: 4 digits marking

Example:

Resistance	5.6Ω	97.6Ω	100Ω	2.2KΩ	10KΩ	49.9KΩ	100KΩ
Marking	5R60	97R6	1000	2201	1002	4992	1003

5% for 0603/0805/1206/1210/2010/2512/1225/0612: 3 digits marking in E24

Example: 101=100Ω 102=1KΩ (1st and 2nd are E24 code and 3rd code is multiplier)

E24 code	10	11	12	13	15	16	18	20	22	24	27	30	33	36	39	43	47	51	56	62	68	75	82	91
----------	----	----	----	----	----	----	----	----	----	----	----	----	----	----	----	----	----	----	----	----	----	----	----	----

Thick Film Chip Resistor

1% for 0603(E24): 3 digits marking in E24, When the E24 and E96 are the same resistance, this marking in E96

Example: 01A= 100Ω 05C=11KΩ 123=12KΩ 273=27KΩ

1% for 0603: 3 digits marking in E96

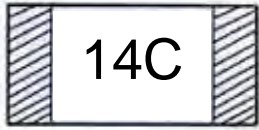

3 digits marking for Example: 14C=13K7Ω 13C=13K3Ω
68B=4K99Ω 68X=49.9Ω

Marking Table

Code	E96	Code	E96	Code	E96	Code	E96				
01	100	25	178	49	316	73	562				
02	102	26	182	50	324	74	576				
03	105	27	187	51	332	75	590				
04	107	28	191	52	340	76	604				
05	110	29	196	53	348	77	619				
06	113	30	200	54	357	78	634				
07	115	31	205	55	365	79	649				
08	118	32	210	56	374	80	665				
09	121	33	215	57	383	81	681				
10	124	34	221	58	392	82	698				
11	127	35	226	59	402	83	715				
12	130	36	232	60	412	84	732				
13	133	37	237	61	422	85	750				
14	137	38	243	62	432	86	768				
15	140	39	249	63	442	87	787				
16	143	40	255	64	453	88	806				
17	147	41	261	65	464	89	825				
18	150	42	267	66	475	90	845				
19	154	43	274	67	487	91	866				
20	158	44	280	68	499	92	887				
21	162	45	287	69	511	93	909				
22	165	46	294	70	523	94	931				
23	169	47	301	71	536	95	953				
24	174	48	309	72	549	96	976				
Code	A	B	C	D	E	F	G	X	Y		
Multiplier	10 ⁰	10 ¹	10 ²	10 ³	10 ⁴	10 ⁵	10 ⁶	10 ⁻¹	10 ⁻²		

REVISION HISTORY

REVISION	DATE	CHANGE NOTIFICATION	DESCRIPTION
Version C	Jun 03, 2014	-	- Environmental Characteristics updated - Size CR-25 specifications added
Version C1	Apr 30, 2015	-	- High Power & Ultra High Power Rating Electrical Increase Jumper Specifications
Version C2	Jun 09, 2015	-	- Increase 0603(E24) 1% marking description
Version C3	Jul 15, 2016	-	- Remove Material Description - Size CR-62 specifications added - Modify Storage Temperature
Version C4	Jan 12, 2018	-	- Modify Electrical Specifications (0R) - Modify 1225 Dimension L, W - Modify 2512 Land Pattern
Version C5	May 20, 2019	-	- Modify TCR Test description