



## 10N65-HC

Power MOSFET

### 10A, 650V N-CHANNEL POWER MOSFET

#### DESCRIPTION

The **UTC 10N65-HC** is a high voltage and high current power MOSFET, designed to have better characteristics, such as fast switching time, low gate charge, low on-state resistance and a high rugged avalanche characteristics. This power MOSFET is usually used at high speed switching applications in power supplies, PWM motor controls, high efficient AC to DC converters and bridge circuits.

#### FEATURES

- \*  $R_{DS(ON)} \leq 0.78\Omega @ V_{GS}=10V, I_D=5.0A$
- \* Fast switching
- \* Improved dv/dt capability

#### SYMBOL

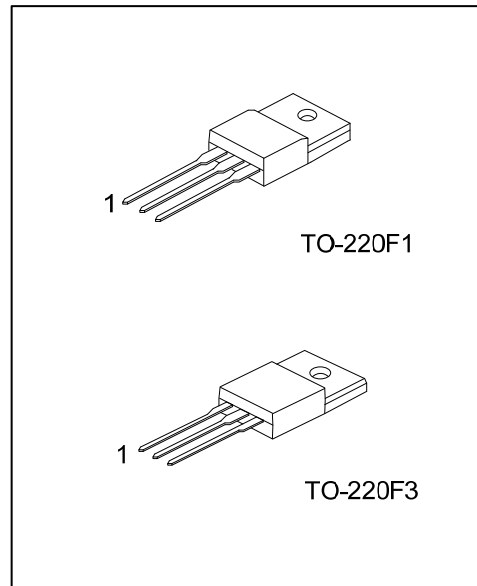
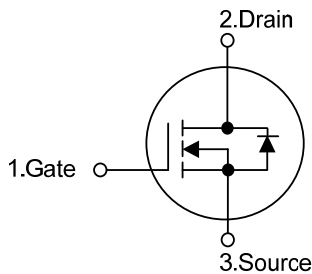

#### ORDERING INFORMATION

Ordering Number		Package	Pin Assignment			Packing
Lead Free	Halogen-Free		1	2	3	
10N65L-TF1-T	10N65G-TF1-T	TO-220F1	G	D	S	Tube
10N65L-TF3T-T	10N65G-TF3T-T	TO-220F3	G	D	S	Tube

Note: Pin Assignment: G: Gate D: Drain S: Source

<p>10N65G-TF1-T</p>	<p>(1) T: Tube</p> <p>(2) TF1: TF3T: TO-220F1, TF3T: TO-220F3</p> <p>(3) G: Halogen Free and Lead Free, L: Lead Free</p>
---------------------	--

#### MARKING

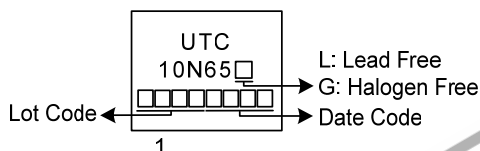

■ ABSOLUTE MAXIMUM RATINGS ( $T_C = 25^\circ\text{C}$ , unless otherwise specified)

PARAMETER		SYMBOL	RATINGS	UNIT
Drain-Source Voltage		$V_{DSS}$	650	V
Gate-Source Voltage		$V_{GSS}$	$\pm 30$	V
Drain Current	Continuous	$I_D$	10	A
	Pulsed (Note 2)	$I_{DM}$	20	A
Avalanche Energy	Single Pulsed (Note 3)	$E_{AS}$	190.2	mJ
Peak Diode Recovery dv/dt (Note 4)		dv/dt	3.09	V/ns
Power Dissipation		$P_D$	35	W
Junction Temperature		$T_J$	+150	$^\circ\text{C}$
Storage Temperature		$T_{STG}$	-55 ~ +150	$^\circ\text{C}$

Notes: 1. Absolute maximum ratings are those values beyond which the device could be permanently damaged.

Absolute maximum ratings are stress ratings only and functional device operation is not implied.

2. Repetitive Rating: Pulse width limited by maximum junction temperature.

3.  $L = 10\text{mH}$ ,  $I_{AS} = 6.2\text{A}$ ,  $V_{DD} = 50\text{V}$ ,  $R_G = 25\ \Omega$  Starting  $T_J = 25^\circ\text{C}$

4.  $I_{SD} \leq 10\text{A}$ ,  $di/dt \leq 200\text{A}/\mu\text{s}$ ,  $V_{DD} \leq BV_{DSS}$ , Starting  $T_J = 25^\circ\text{C}$

■ THERMAL DATA

PARAMETER	SYMBOL	RATINGS	UNIT
Junction to Ambient	$\theta_{JA}$	62.5	$^\circ\text{C}/\text{W}$
Junction to Case	$\theta_{JC}$	3.57	$^\circ\text{C}/\text{W}$

■ ELECTRICAL CHARACTERISTICS ( $T_J = 25^\circ\text{C}$ , unless otherwise specified)

PARAMETER	SYMBOL	TEST CONDITIONS	MIN	TYP	MAX	UNIT
<b>OFF CHARACTERISTICS</b>						
Drain-Source Breakdown Voltage	$BV_{DSS}$	$V_{GS}=0\text{V}$ , $I_D=250\mu\text{A}$	650			V
Drain-Source Leakage Current	$I_{DSS}$	$V_{DS}=650\text{V}$ , $V_{GS}=0\text{V}$			10	$\mu\text{A}$
Gate-Source Leakage Current	Forward	$I_{GSS}$			100	nA
	Reverse					
					-100	nA
<b>ON CHARACTERISTICS</b>						
Gate Threshold Voltage	$V_{GS(TH)}$	$V_{DS}=V_{GS}$ , $I_D=250\mu\text{A}$	2.0		4.0	V
Static Drain-Source On-State Resistance	$R_{DS(ON)}$	$V_{GS}=10\text{V}$ , $I_D=5.0\text{A}$			0.78	$\Omega$
<b>DYNAMIC CHARACTERISTICS</b>						
Input Capacitance	$C_{ISS}$	$V_{GS}=0\text{V}$ , $V_{DS}=25\text{V}$ , $f=1.0\text{MHz}$		1595		pF
Output Capacitance	$C_{OSS}$			205		pF
Reverse Transfer Capacitance	$C_{RSS}$			35		pF
<b>SWITCHING CHARACTERISTICS</b>						
Total Gate Charge (Note 1)	$Q_G$	$V_{DS}=520\text{V}$ , $V_{GS}=10\text{V}$ , $I_D=10\text{A}$ $I_G=1\text{mA}$ (Note 1, 2)		48		nC
Gate-source Charge	$Q_{GS}$			8.5		nC
Gate-drain Charge	$Q_{GD}$			17		nC
Turn-on Delay Time (Note 1)	$t_{D(ON)}$	$V_{DS}=100\text{V}$ , $V_{GS}=10\text{V}$ , $I_D=10\text{A}$ , $R_G=25\ \Omega$ (Note 1, 2)		23		ns
Rise Time	$t_R$			31		ns
Turn-off Delay Time	$t_{D(OFF)}$			163		ns
Fall-Time	$t_F$			65		ns
<b>SOURCE- DRAIN DIODE RATINGS AND CHARACTERISTICS</b>						
Maximum Continuous Drain-Source Diode Forward Current	$I_S$				10	A
Maximum Pulsed Drain-Source Diode Forward Current	$I_{SM}$				40	A
Drain-Source Diode Forward Voltage (Note 1)	$V_{SD}$	$V_{GS}=0\text{V}$ , $I_S=10\text{A}$			1.4	V
Reverse Recovery Time (Note 1)	$t_{rr}$	$V_{GS}=0\text{V}$ , $I_S=10\text{A}$ ,		330		ns
Reverse Recovery Charge	$Q_{rr}$	$di/dt=100\text{A}/\mu\text{s}$ (Note1)		3.5		$\mu\text{C}$

Notes: 1. Pulse Test : Pulse width  $\leq 300\mu\text{s}$ , Duty cycle  $\leq 2\%$ .

2. Essentially independent of operating temperature.

## TEST CIRCUITS AND WAVEFORMS

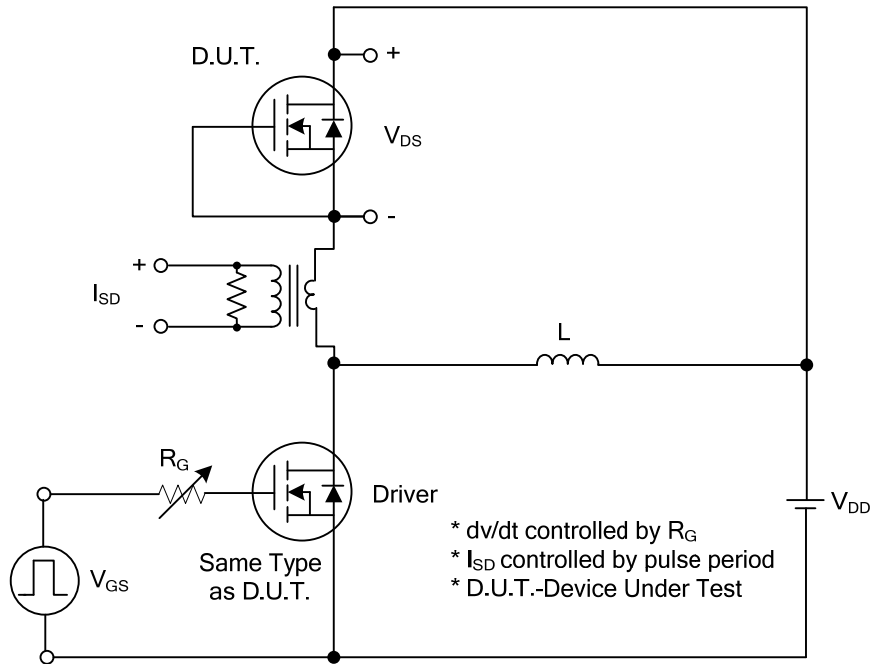

**Peak Diode Recovery  $dv/dt$  Test Circuit**

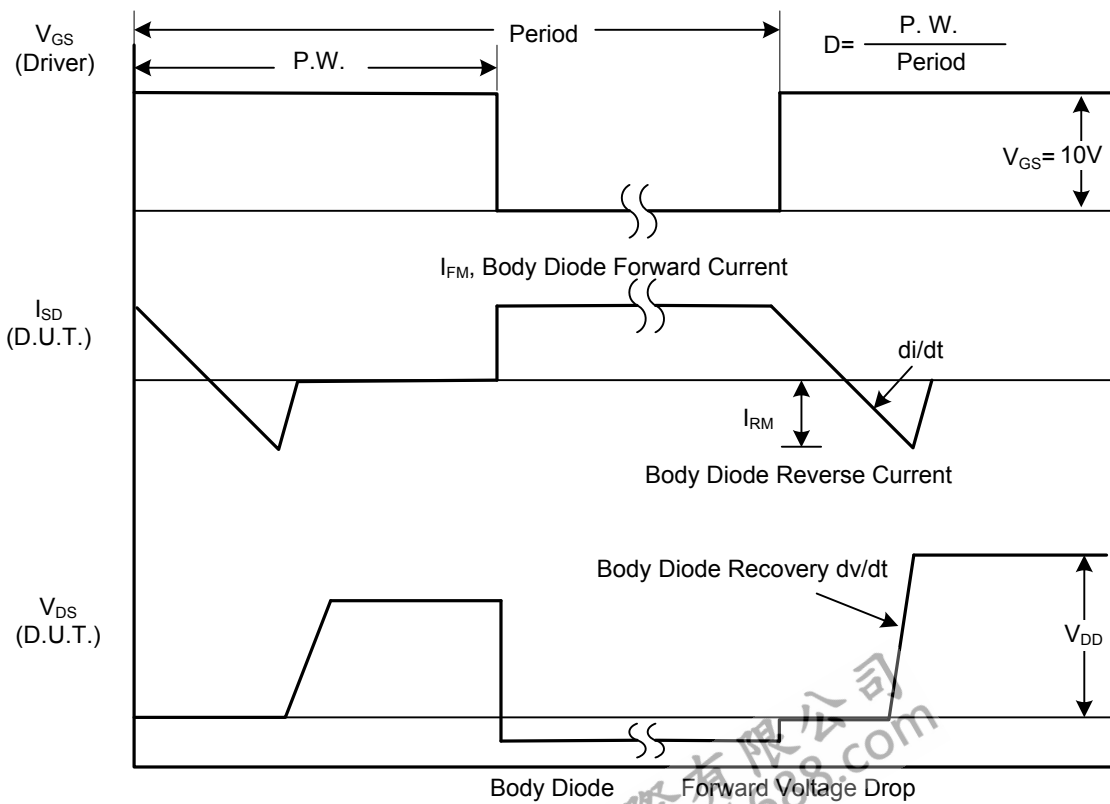

**Peak Diode Recovery  $dv/dt$  Waveforms**

## TEST CIRCUITS AND WAVEFORMS

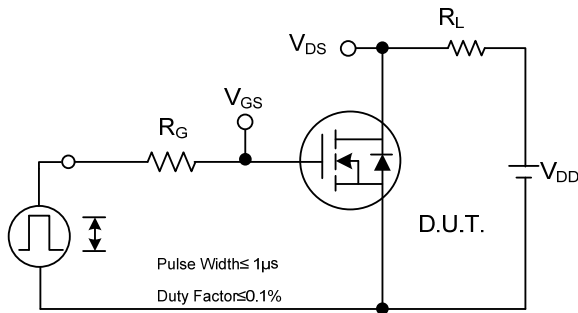

Switching Test Circuit

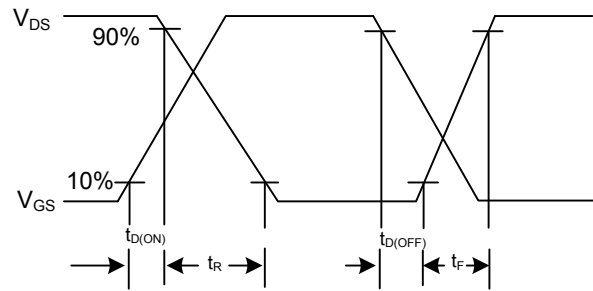

Switching Waveforms

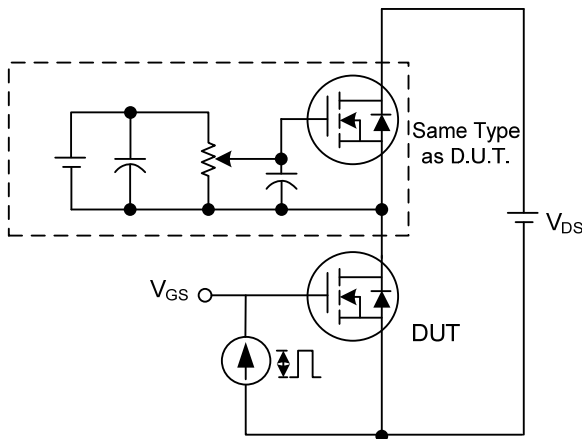

Gate Charge Test Circuit

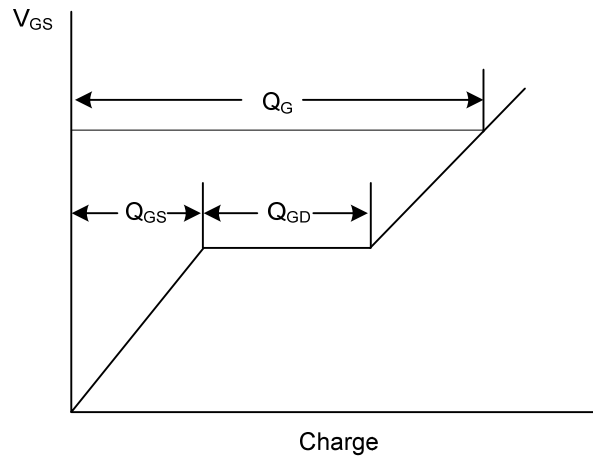

Gate Charge Waveform

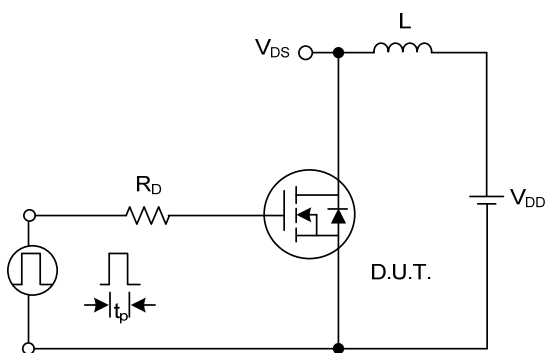

Unclamped Inductive Switching Test Circuit

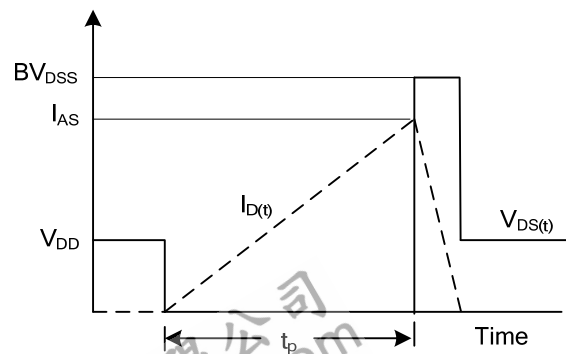

Unclamped Inductive Switching Waveforms

### TYPICAL CHARACTERISTICS

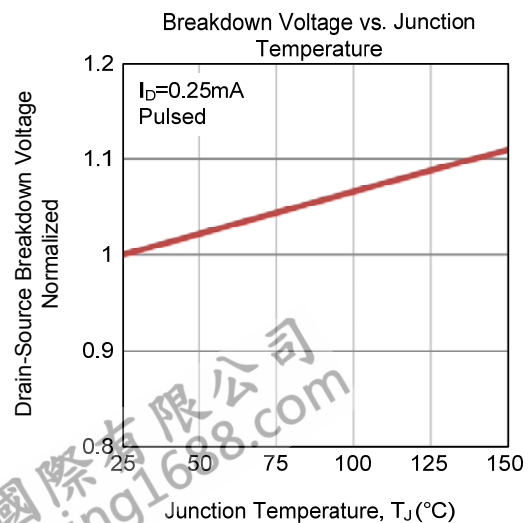
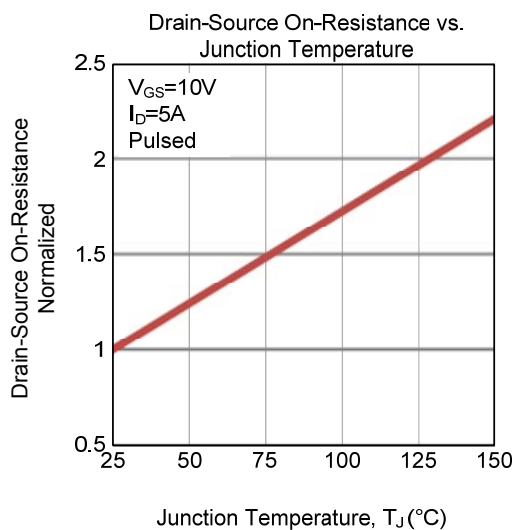
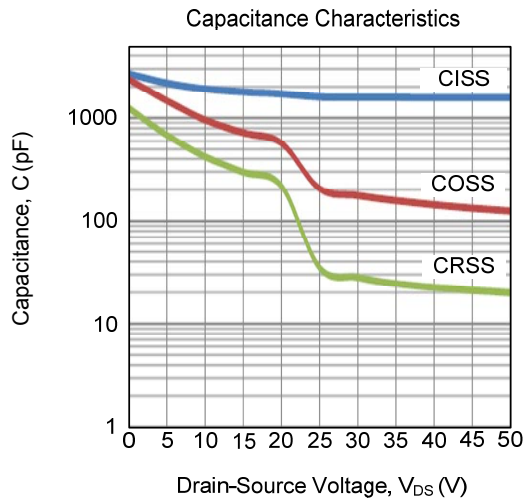
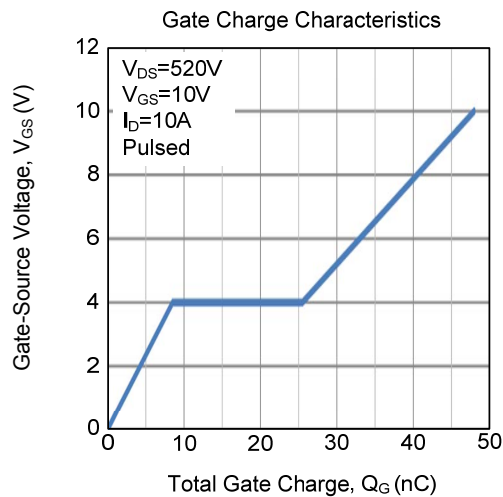
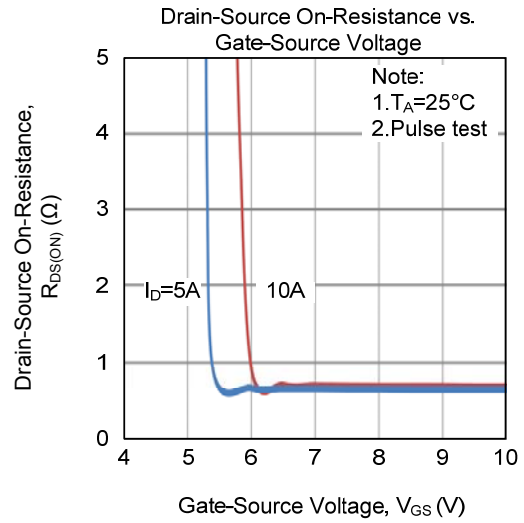
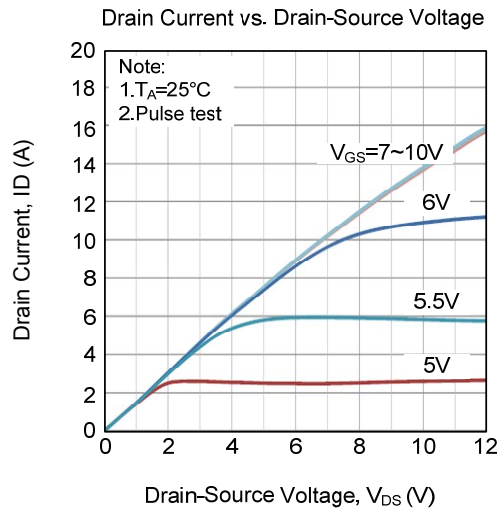

### ■ TYPICAL CHARACTERISTICS (Cont.)

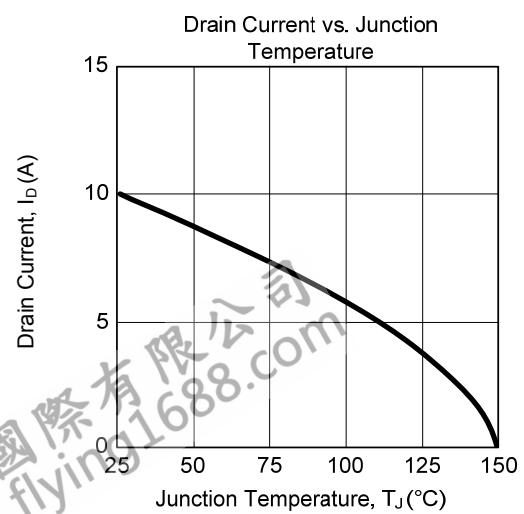
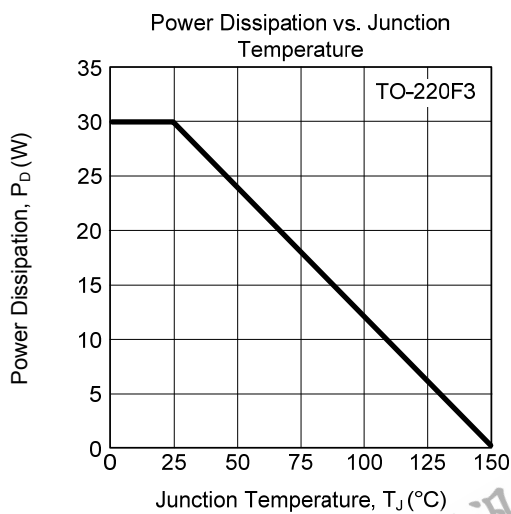
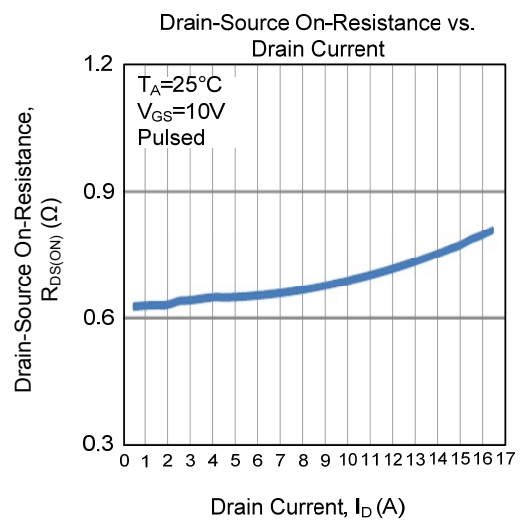
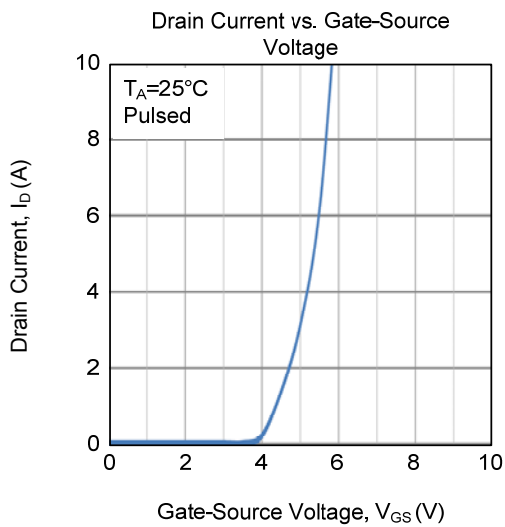
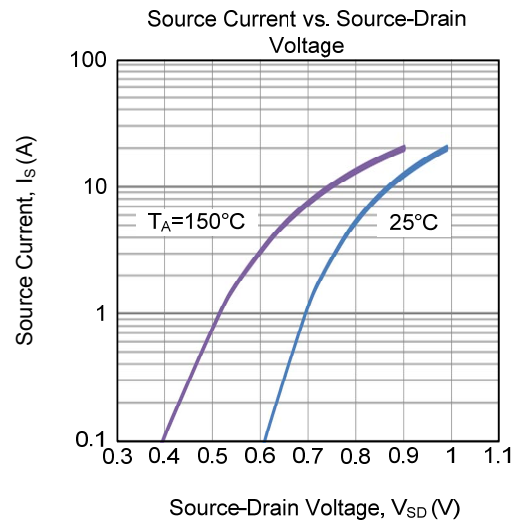
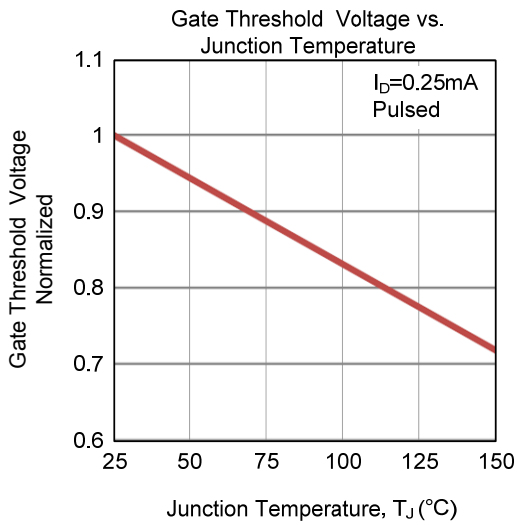

■ TYPICAL CHARACTERISTICS (Cont.)

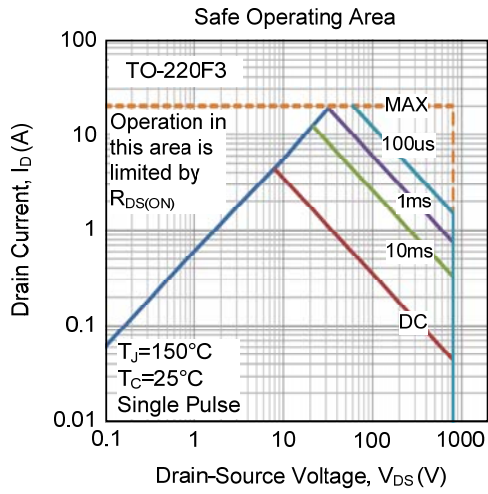

UTC assumes no responsibility for equipment failures that result from using products at values that exceed, even momentarily, rated values (such as maximum ratings, operating condition ranges, or other parameters) listed in products specifications of any and all UTC products described or contained herein. UTC products are not designed for use in life support appliances, devices or systems where malfunction of these products can be reasonably expected to result in personal injury. Reproduction in whole or in part is prohibited without the prior written consent of the copyright owner. UTC reserves the right to make changes to information published in this document, including without limitation specifications and product descriptions, at any time and without notice. This document supersedes and replaces all information supplied prior to the publication hereof.