



11N50

Preliminary

Power MOSFET

11A, 500V N-CHANNEL POWER MOSFET

DESCRIPTION

The **UTC 11N50** is an N-channel enhancement mode power MOSFET. It uses UTC advanced planar stripe, DMOS technology to provide customers perfect switching performance, minimal on-state resistance. It also can withstand high energy pulse in the avalanche and commutation mode.

The **UTC 11N50** is universally applied in electronic lamp ballasts based on half bridge topology, high efficiency switched mode power supplies, active power factor correction, etc.

FEATURES

- * $R_{DS(ON)}=0.55\Omega @ V_{GS}=10V$
- * Fast Switching
- * With 100% Avalanche Tested

SYMBOL

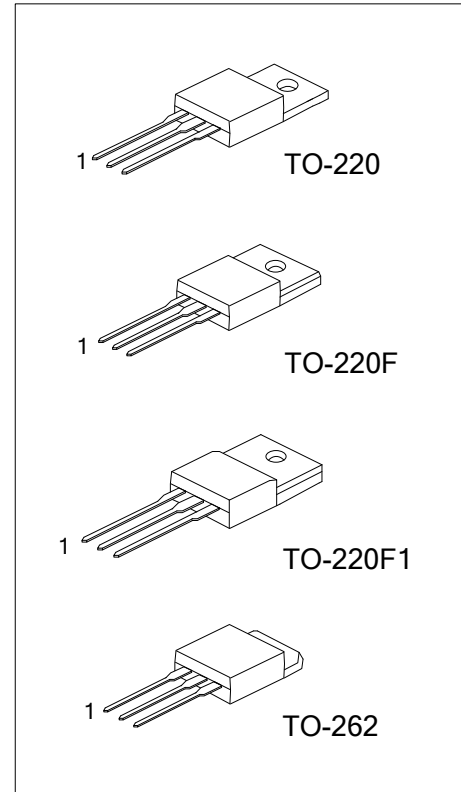
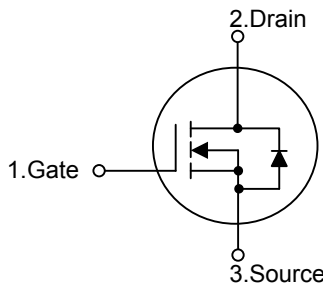

ORDERING INFORMATION

Ordering Number		Package	Pin Assignment			Packing
Lead Free	Halogen Free		1	2	3	
11N50L-TA3-T	11N50G-TA3-T	TO-220	G	D	S	Tube
11N50L-TF1-T	11N50G-TF1-T	TO-220F1	G	D	S	Tube
11N50L-TF3-T	11N50G-TF3-T	TO-220F	G	D	S	Tube
11N50L-T2Q-T	11N50G-T2Q-T	TO-262	G	D	S	Tube

<p>11N50L-TA3-T</p> <p>(1) Packing Type (2) Package Type (3) Lead Free</p>	<p>(1) T: Tube (2) TA3: TO-220, TF1:TO-220F1, TF3: TO-220F, T2Q: TO-262 (3) L: Lead Free, G: Halogen Free</p>
------------------------------------------------------------------------------------	-----------------------------------------------------------------------------------------------------------------------

■ ABSOLUTE MAXIMUM RATINGS ($T_C = 25^\circ\text{C}$, unless otherwise specified)

PARAMETER		SYMBOL	RATINGS	UNIT
Drain to Source Voltage		V_{DSS}	500	V
Gate to Source Voltage		V_{GSS}	± 30	V
Continuous Drain Current	$T_C=25^\circ\text{C}$	I_D	11 (Note 2)	A
	$T_C=100^\circ\text{C}$		7 (Note 2)	A
Pulsed Drain Current (Note 3)		I_{DM}	44 (Note 2)	A
Single Pulsed Avalanche Energy (Note 4)		E_{AS}	670	mJ
Peak Diode Recovery dv/dt (Note 5)		dv/dt	4.5	V/ns
Power Dissipation	$T_C=25^\circ\text{C}$	TO-220	195	W
		TO-220F1	40	
		TO-220F	48	
		TO-262	195	
	Derate above 25°C	TO-220	1.56	W/ $^\circ\text{C}$
		TO-220F1	0.32	
		TO-220F	0.39	
		TO-262	1.56	
Junction Temperature		T_J	+150	$^\circ\text{C}$
Storage Temperature		T_{STG}	-55 ~ +150	$^\circ\text{C}$

Note: 1. Absolute maximum ratings are those values beyond which the device could be permanently damaged. Absolute maximum ratings are stress ratings only and functional device operation is not implied.

2. Drain current limited by maximum junction temperature
3. Repetitive Rating : Pulse width limited by maximum junction temperature
4. $L=10\text{mH}$, $I_{AS}=11\text{A}$, $V_{DD}=50\text{V}$, $R_G=25\Omega$, Starting $T_J=25^\circ\text{C}$
5. $I_{SD}\leq 11\text{A}$, $di/dt\leq 200\text{A}/\mu\text{s}$, $V_{DD}\leq BV_{DSS}$, Starting $T_J=25^\circ\text{C}$

■ THERMAL DATA

PARAMETER		SYMBOL	RATINGS	UNIT
Junction to Ambient		θ_{JA}	62.5	$^\circ\text{C}/\text{W}$
Junction to Case	TO-220	θ_{JC}	0.64	$^\circ\text{C}/\text{W}$
	TO-220F1		3.1	
	TO-220F		2.58	
	TO-262		0.64	

■ ELECTRICAL CHARACTERISTICS (T_C=25°C, unless otherwise specified)

PARAMETER	SYMBOL	TEST CONDITIONS	MIN	TYP	MAX	UNIT
OFF CHARACTERISTICS						
Drain-Source Breakdown Voltage	BV _{DSS}	V _{GS} =0V, I _D =250μA	500			V
Breakdown Voltage Temperature Coefficient	ΔBV _{DSS} /ΔT _J	I _D =250μA, Referenced to 25°C		0.5		V/°C
Drain-Source Leakage Current	I _{DSS}	V _{DS} =500V, V _{GS} =0V			10	μA
		V _{DS} =500V, T _J =125°C			100	μA
Gate-Source Leakage Current	I _{GSS}	V _{DS} =0V, V _{GS} =±30V			±100	nA
ON CHARACTERISTICS						
Gate Threshold Voltage	V _{GS(TH)}	V _{DS} =V _{GS} , I _D =250μA	2.0		4.0	V
Drain-Source On-State Resistance	R _{DS(ON)}	V _{GS} =10V, I _D =5.5A		0.48	0.55	Ω
DYNAMIC PARAMETERS						
Input Capacitance	C _{ISS}	V _{DS} =25V, V _{GS} =0V, f=1.0MHz		1515	2055	pF
Output Capacitance	C _{OSS}			185	235	pF
Reverse Transfer Capacitance	C _{RSS}			25	30	pF
SWITCHING PARAMETERS						
Total Gate Charge	Q _G	V _{DS} =400V, V _{GS} =10V, I _D =11A (Note 1, 2)		43	55	nC
Gate-Source Charge	Q _{GS}			8		nC
Gate-Drain Charge	Q _{GD}			19		nC
Turn-ON Delay Time	t _{D(ON)}	V _{DD} =250V, I _D =11A, R _G =3Ω (Note 1, 2)		24	57	ns
Turn-ON Rise Time	t _R			70	150	ns
Turn-OFF Delay Time	t _{D(OFF)}			120	250	ns
Turn-OFF Fall Time	t _F			75	160	ns
SOURCE- DRAIN DIODE RATINGS AND CHARACTERISTICS						
Maximum Body-Diode Continuous Current	I _S				11	A
Maximum Body-Diode Pulsed Current	I _{SM}				44	A
Drain-Source Diode Forward Voltage	V _{SD}	I _S =11A, V _{GS} =0V			1.4	V
Body Diode Reverse Recovery Time	t _{rr}	V _{GS} =0V, I _S =11A, dI _F /dt=100A/μs (Note 1)		90		ns
Body Diode Reverse Recovery Charge	Q _{RR}				1.5	

Note: 1. Pulse Test : Pulse width ≤ 300μs, Duty cycle ≤ 2%

2. Essentially independent of operating temperature

■ TEST CIRCUITS AND WAVEFORMS

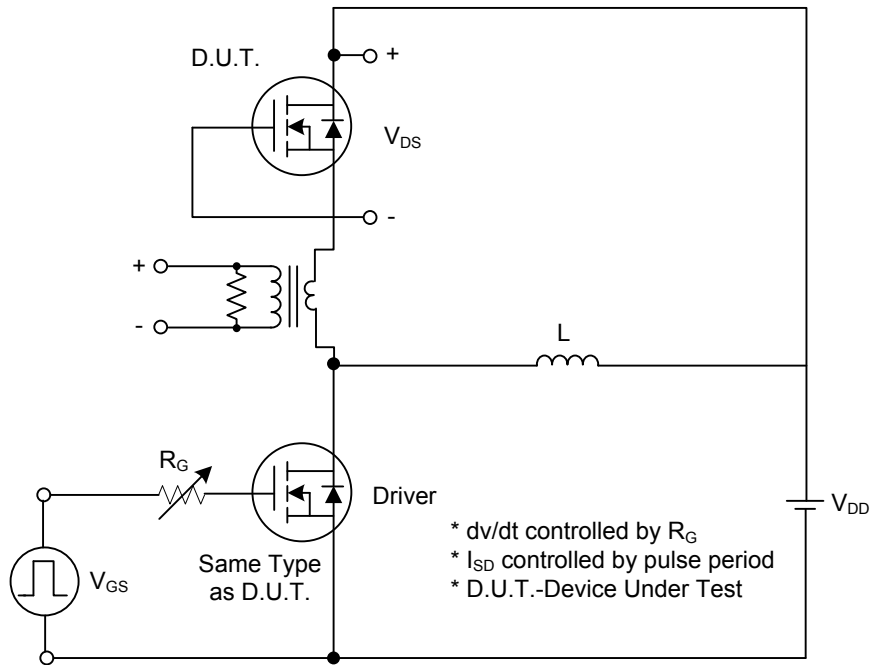

Peak Diode Recovery dv/dt Test Circuit

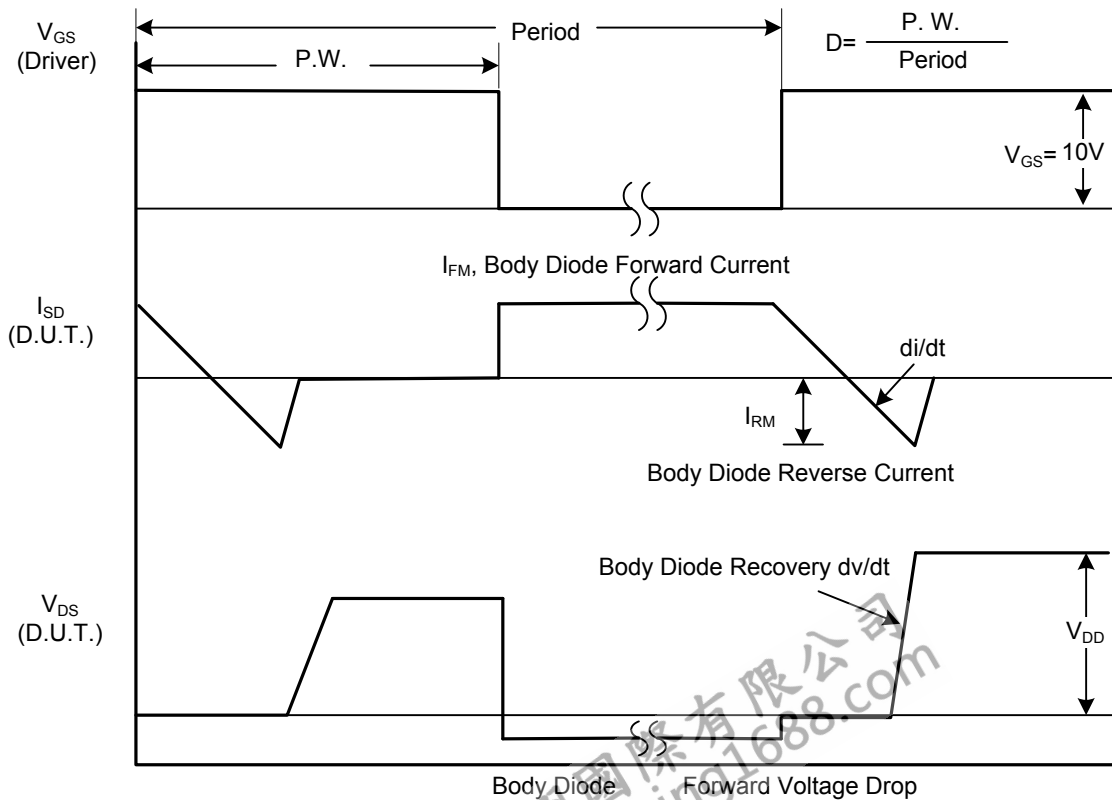

Peak Diode Recovery dv/dt Waveforms

■ TEST CIRCUITS AND WAVEFORMS (Cont.)

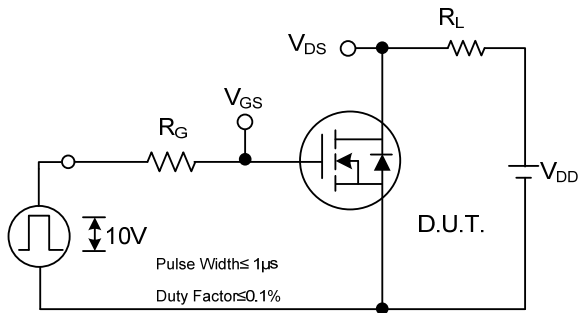

Switching Test Circuit

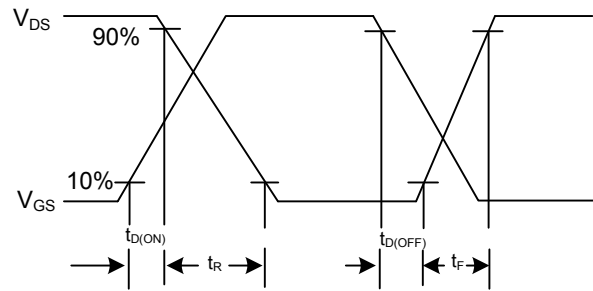

Switching Waveforms

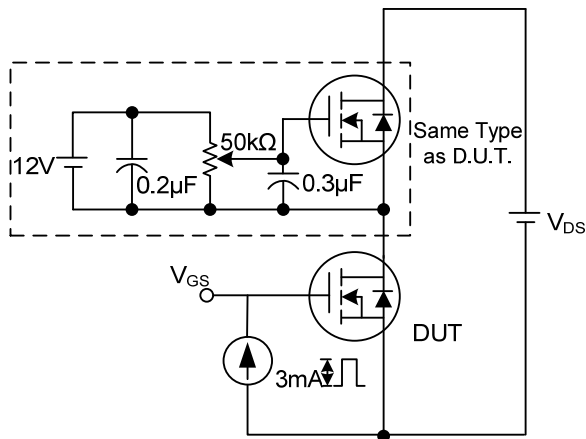

Gate Charge Test Circuit

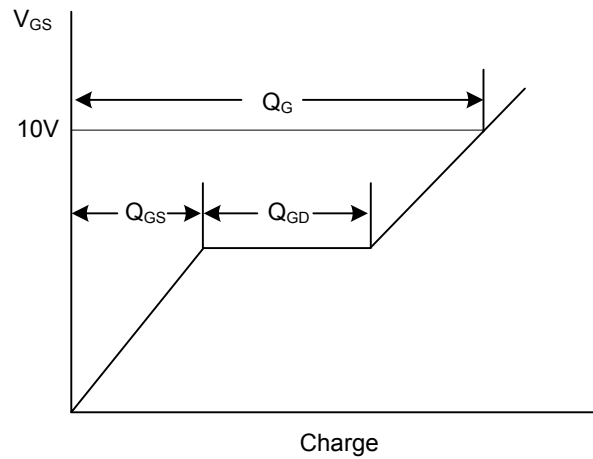

Gate Charge Waveform

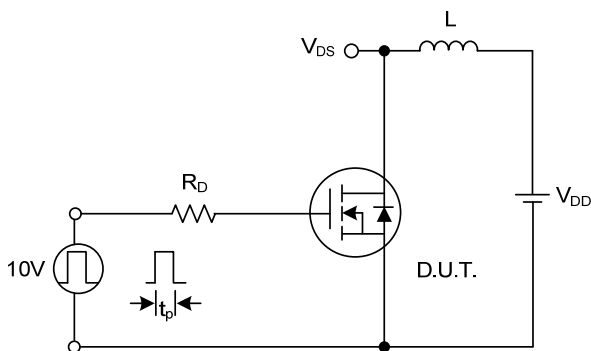

Unclamped Inductive Switching Test Circuit

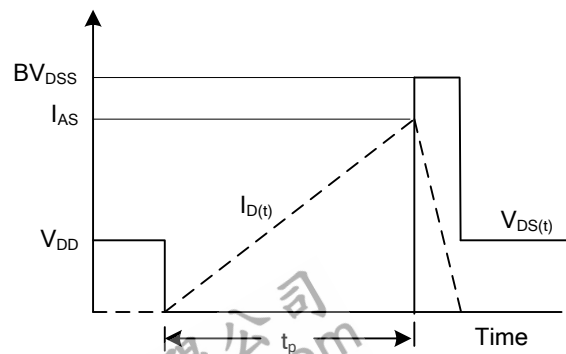

Unclamped Inductive Switching Waveforms

UTC assumes no responsibility for equipment failures that result from using products at values that exceed, even momentarily, rated values (such as maximum ratings, operating condition ranges, or other parameters) listed in products specifications of any and all UTC products described or contained herein. UTC products are not designed for use in life support appliances, devices or systems where malfunction of these products can be reasonably expected to result in personal injury. Reproduction in whole or in part is prohibited without the prior written consent of the copyright owner. The information presented in this document does not form part of any quotation or contract, is believed to be accurate and reliable and may be changed without notice.