



## 15N40K-MT

Power MOSFET

### 15A, 400V N-CHANNEL POWER MOSFET

#### DESCRIPTION

The UTC **15N40K-MT** is an N-channel mode power MOSFET using UTC's advanced technology to provide customers with planar stripe and DMOS technology. This technology allows a minimum on-state resistance and superior switching performance. It also can withstand high energy pulse in the avalanche and commutation mode.

The UTC **15N40K-MT** is generally applied in high efficiency switch mode power supplies.

#### FEATURES

\*  $R_{DS(ON)} < 0.30\Omega @ V_{GS} = 10V, I_D = 7.5A$

\* High Switching Speed

#### SYMBOL

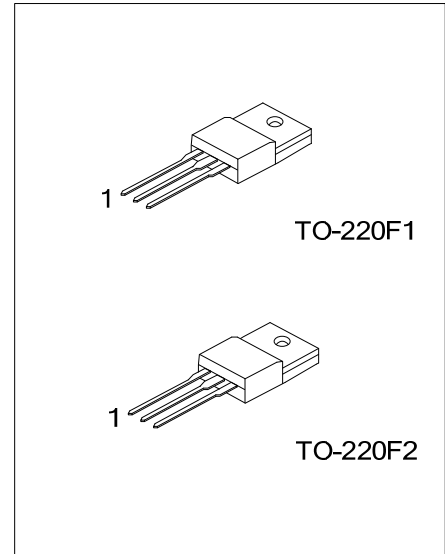
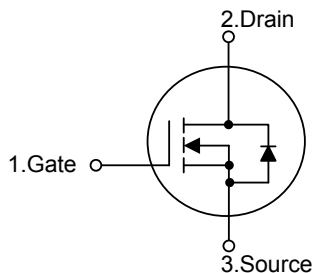

#### ORDERING INFORMATION

Ordering Number		Package	Pin Assignment			Packing
Lead Free	Halogen Free		1	2	3	
15N40KL-TF1-T	15N40KG-TF1-T	TO-220F1	G	D	S	Tube
15N40KL-TF2-T	15N40KG-TF2-T	TO-220F2	G	D	S	Tube

Note: Pin Assignment: G: Gate D: Drain S: Source

<p>15N40KL-TF2-T</p> <p>(1) Packing Type</p> <p>(2) Package Type</p> <p>(3) Green Package</p>	<p>(1) T: Tube</p> <p>(2) TF1: TO-220F1, TF2: TO-220F2</p> <p>(3) L: Lead Free, G: Halogen Free and Lead Free</p>
---	---

#### MARKING

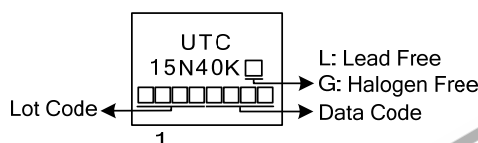

■ ABSOLUTE MAXIMUM RATINGS ( $T_C=25^\circ\text{C}$ , unless otherwise specified.) (Note 5)

PARAMETER		SYMBOL	RATINGS	UNIT
Drain to Source Voltage		$V_{DSS}$	400	V
Gate-Source Voltage		$V_{GSS}$	$\pm 30$	V
Drain Current	Continuous $T_C=25^\circ\text{C}$	$I_D$	15	A
	Pulsed (Note 2)	$I_{DM}$	60	A
Avalanche Current (Note 2)		$I_{AR}$	15	A
Avalanche Energy	Single Pulsed (Note 3)	$E_{AS}$	586	mJ
Peak Diode Recovery dv/dt (Note 4)		dv/dt	15	V/ns
Power Dissipation ( $T_C=25^\circ\text{C}$ )	TO-220F1	$P_D$	170	W
	TO-220F2		52	W
Derate above $25^\circ\text{C}$	TO-220F1		1.45	W/ $^\circ\text{C}$
	TO-220F2		0.416	W/ $^\circ\text{C}$
Junction Temperature		$T_J$	+150	$^\circ\text{C}$
Storage Temperature		$T_{STG}$	-55 ~ +150	$^\circ\text{C}$

Notes: 1. Absolute maximum ratings are those values beyond which the device could be permanently damaged.

Absolute maximum ratings are stress ratings only and functional device operation is not implied.

2. Repetitive Rating; Pulse width limited by maximum junction temperature.

3.  $L=5.21\text{mH}$ ,  $I_{AS}=15\text{A}$ ,  $V_{DD}=50\text{V}$ ,  $R_G=25\Omega$ , Starting  $T_J=25^\circ\text{C}$

4.  $I_{SD}\leq 15\text{A}$ ,  $di/dt\leq 200\text{A}/\mu\text{s}$ ,  $V_{DD}\leq BV_{DSS}$ , Starting  $T_J=25^\circ\text{C}$

5. Drain current limited by maximum junction temperature.

■ THERMAL DATA

PARAMETER		SYMBOL	RATINGS	UNIT
Junction to Ambient		$\theta_{JA}$	62.5	$^\circ\text{C}/\text{W}$
Junction to Case	TO-220F1	$\theta_{JC}$	0.7	$^\circ\text{C}/\text{W}$
	TO-220F2		2.4	$^\circ\text{C}/\text{W}$

■ ELECTRICAL CHARACTERISTICS

PARAMETER	SYMBOL	TEST CONDITIONS	MIN	TYP	MAX	UNIT
<b>OFF CHARACTERISTICS</b>						
Drain-Source Breakdown Voltage	$BV_{DSS}$	$I_D=250\mu A, V_{GS}=0V, T_J=25^\circ C$	400			V
Breakdown Voltage Temperature Coefficient	$\Delta BV_{DSS}/\Delta T_J$	Reference to $25^\circ C, I_D=250\mu A$		0.5		$V/^\circ C$
Drain-Source Leakage Current	$I_{DSS}$	$V_{DS}=400V, V_{GS}=0V,$			1	$\mu A$
		$V_{DS}=320V, T_C=125^\circ C$			10	$\mu A$
Gate- Source Leakage Current	Forward	$V_{GS}=+30V, V_{DS}=0V$			+100	nA
	Reverse	$V_{GS}=-30V, V_{DS}=0V$			-100	nA
<b>ON CHARACTERISTICS</b>						
Gate Threshold Voltage	$V_{GS(TH)}$	$V_{GS}=V_{DS}, I_D=250\mu A$	2.0		4.0	V
Static Drain-Source On-State Resistance	$R_{DS(ON)}$	$V_{GS}=10V, I_D=7.5A$		0.23	0.30	$\Omega$
<b>DYNAMIC PARAMETERS</b>						
Input Capacitance	$C_{ISS}$	$V_{DS}=25V, V_{GS}=0V, f=1.0MHz$		865		pF
Output Capacitance	$C_{OSS}$			200		pF
Reverse Transfer Capacitance	$C_{RSS}$			10.9		pF
<b>SWITCHING PARAMETERS</b>						
Turn-ON Delay Time	$t_{D(ON)}$	$V_{DS}=30V, I_D=0.5A, R_G=25\Omega$ (Note 1, 2)		72		ns
Rise Time	$t_R$			108		ns
Turn-OFF Delay Time	$t_{D(OFF)}$			226		ns
Fall-Time	$t_F$			124		ns
Total Gate Charge	$Q_G$	$V_{GS}=10V, V_{DS}=50V, I_D=1.3A$ (Note 1, 2)		38.6		nC
Gate to Source Charge	$Q_{GS}$			10.2		nC
Gate to Drain ("Miller") Charge	$Q_{GD}$			9.6		nC
<b>SOURCE- DRAIN DIODE RATINGS AND CHARACTERISTICS</b>						
Maximum Body-Diode Continuous Current	$I_S$				15	A
Maximum Body-Diode Pulsed Current	$I_{SM}$				60	A
Drain-Source Diode Forward Voltage	$V_{SD}$	$I_{SD}=15A, V_{GS}=0V$			1.4	V

Notes: 1. Pulse Test: Pulse width  $\leq 300\mu s$ ; Duty Cycle  $\leq 2\%$ .

2. Essentially Independent of Operating Temperature Typical Characteristics.

### TEST CIRCUITS AND WAVEFORMS

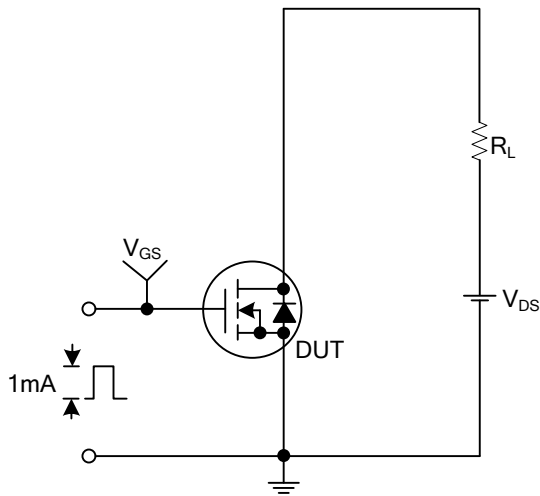

Gate Charge Test Circuit

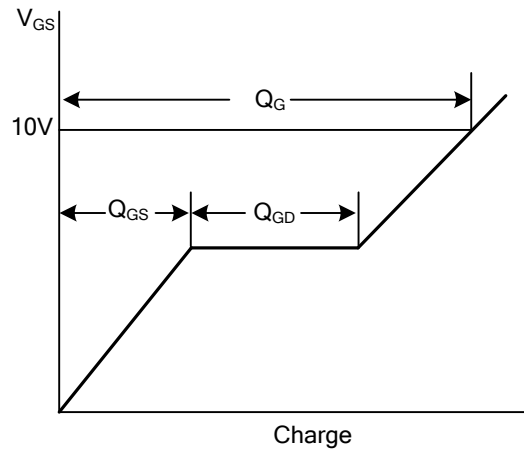

Gate Charge Waveforms

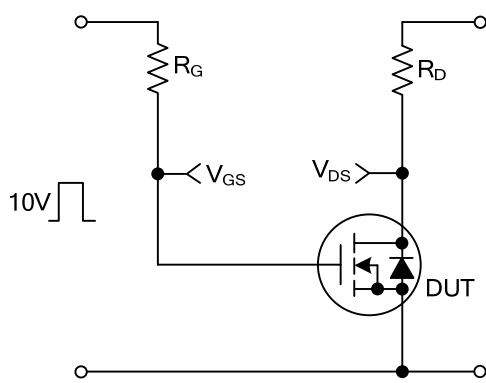

Resistive Switching Test Circuit

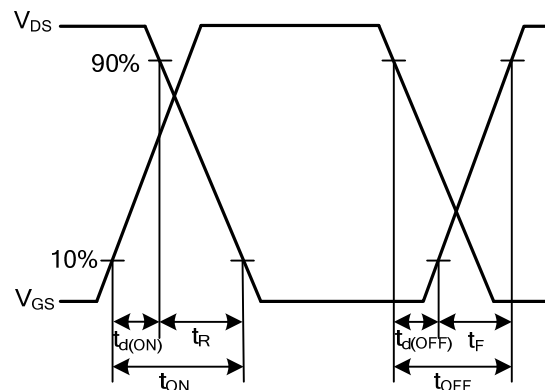

Resistive Switching Waveforms

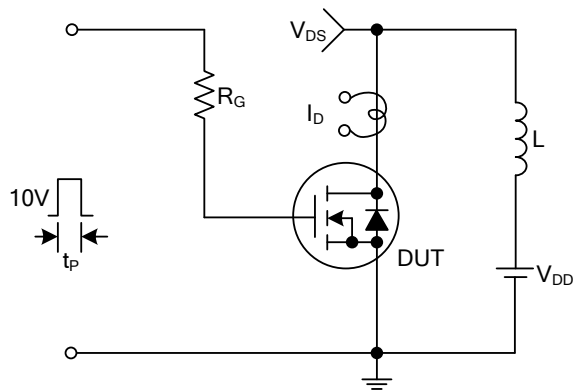

Unclamped Inductive Switching Test Circuit

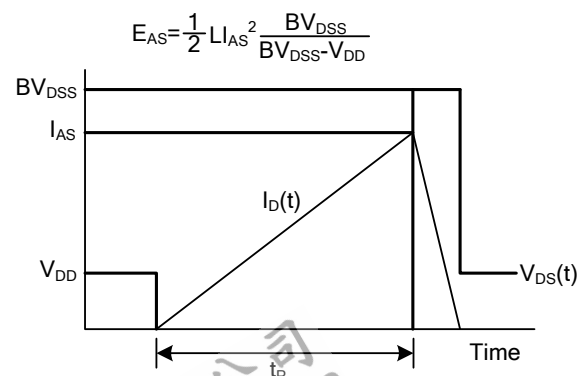

Unclamped Inductive Switching Waveforms

■ TEST CIRCUITS AND WAVEFORMS(Cont.)

Peak Diode Recovery dv/dt Test Circuit & Waveforms

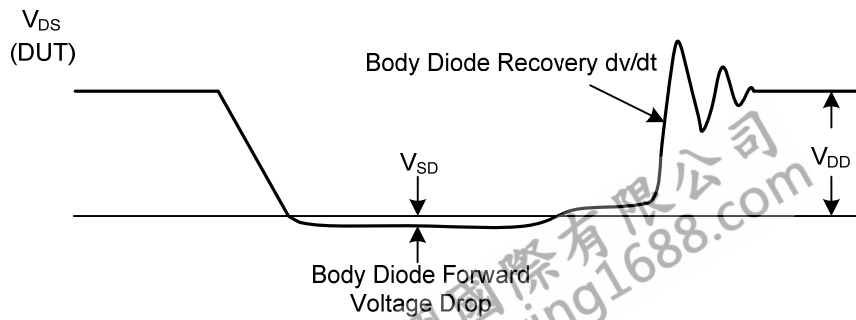
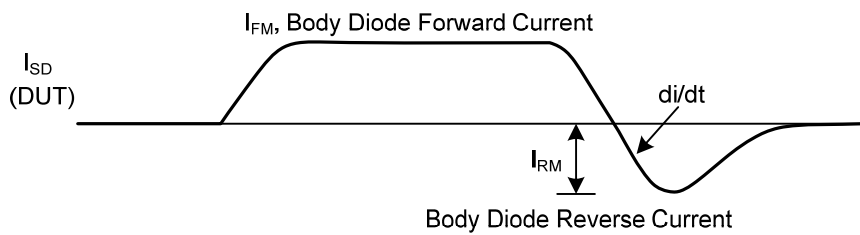
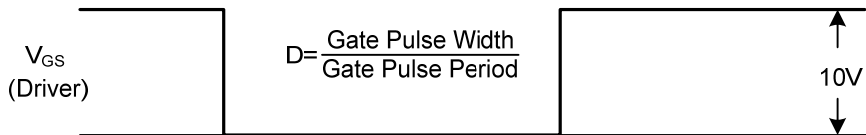
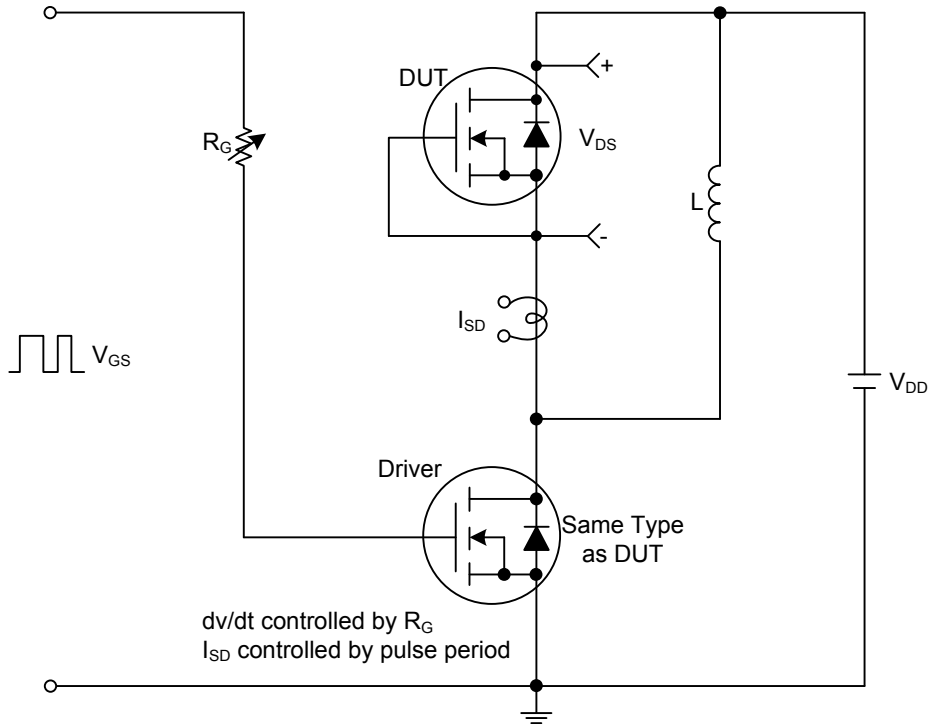

### TYPICAL CHARACTERISTICS

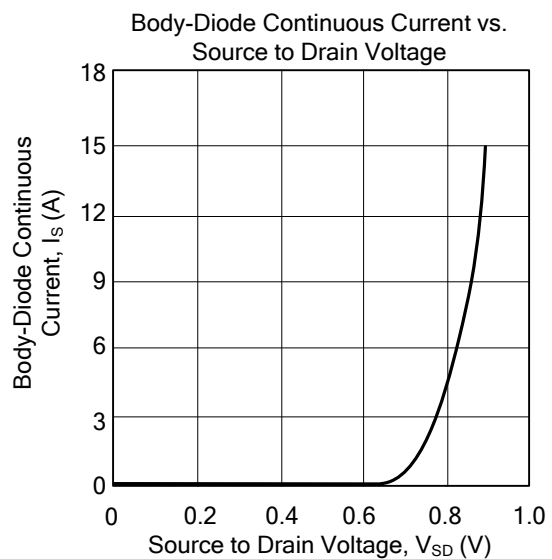
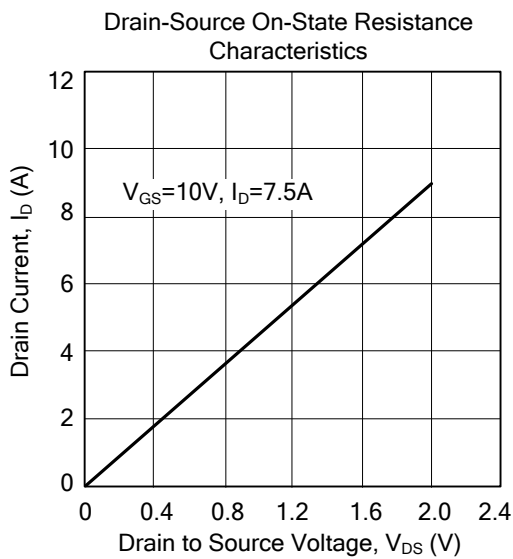
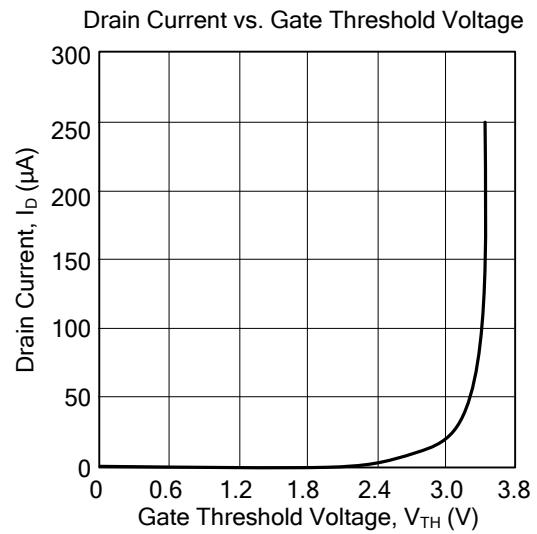
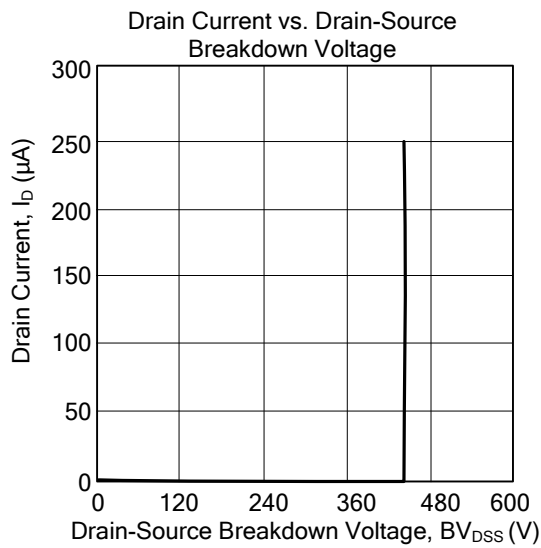

UTC assumes no responsibility for equipment failures that result from using products at values that exceed, even momentarily, rated values (such as maximum ratings, operating condition ranges, or other parameters) listed in products specifications of any and all UTC products described or contained herein. UTC products are not designed for use in life support appliances, devices or systems where malfunction of these products can be reasonably expected to result in personal injury. Reproduction in whole or in part is prohibited without the prior written consent of the copyright owner. The information presented in this document does not form part of any quotation or contract, is believed to be accurate and reliable and may be changed without notice.