



15N50

Power MOSFET

15A, 500V N-CHANNEL POWER MOSFET

■ DESCRIPTION

The UTC **15N50** is an N-channel mode power MOSFET using UTC's advanced technology to provide customers with planar stripe and DMOS technology. This technology allows a minimum on-state resistance and superior switching performance. It also can withstand high energy pulse in the avalanche and commutation mode.

The UTC **15N50** is generally applied in high efficiency switch mode power supplies.

■ FEATURES

- * $R_{DS(ON)} < 0.35\Omega @ V_{GS}=10V$
- * High Switching Speed

■ SYMBOL

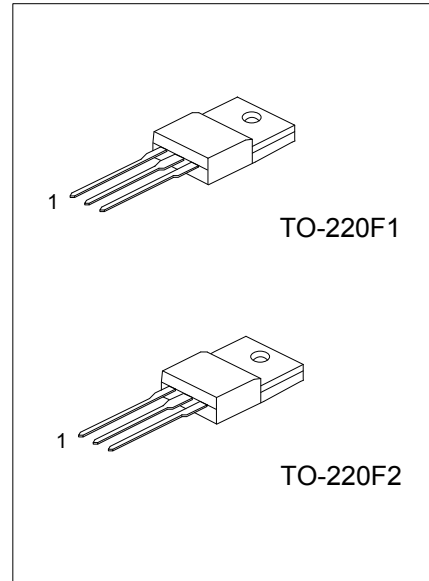
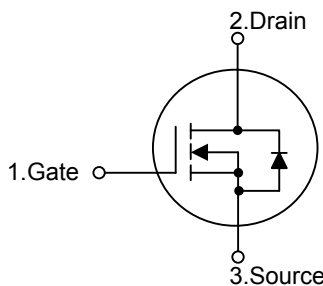

■ ORDERING INFORMATION

Ordering Number		Package	Pin Assignment			Packing
Lead Free	Halogen Free		1	2	3	
15N50L-TF1-T	15N50G-TF1-T	TO-220F1	G	D	S	Tube
15N50L-TF2-T	15N50G-TF2-T	TO-220F2	G	D	S	Tube

Note: Pin Assignment: G: Gate D: Drain S: Source

<p>15N50L-TF1-T</p> <ul style="list-style-type: none"> (1)Packing Type (2)Package Type (3)Lead Free 	<ul style="list-style-type: none"> (1) T: Tube (2) TF1: TO-220F1, TF2: TO-220F2 (3) L: Lead Free, G: Halogen Free
--------------------------------------------------------------------------------------------------------------------------------------	----------------------------------------------------------------------------------------------------------------------------------------------------

■ MARKING INFORMATION

PACKAGE	MARKING
TO-220F1 TO-220F2	<ul style="list-style-type: none"> L: Lead Free G: Halogen Free Data Code

■ ABSOLUTE MAXIMUM RATINGS ($T_C=25^\circ\text{C}$, unless otherwise specified.) (Note 5)

PARAMETER		SYMBOL	RATINGS	UNIT	
Drain to Source Voltage		V_{DSS}	500	V	
Gate-Source Voltage		V_{GSS}	± 30	V	
Drain Current	Continuous	I_D	$T_C=25^\circ\text{C}$	15	A
			$T_C=100^\circ\text{C}$	9	A
	Pulsed (Note 2)		I_{DM}	60	A
Avalanche Current (Note 2)		I_{AR}	15	A	
Avalanche Energy	Single Pulsed (Note 3)		E_{AS}	731	mJ
	Repetitive (Note 2)		E_{AR}	17	mJ
Peak Diode Recovery dv/dt (Note 4)		dv/dt	15	V/ns	
Power Dissipation ($T_C=25^\circ\text{C}$)	TO-220F1	P_D	48	W	
	TO-220F2		52		
Derate above 25°C	TO-220F1		0.384	W/ $^\circ\text{C}$	
	TO-220F2		0.416		
Junction Temperature		T_J	+150	$^\circ\text{C}$	
Storage Temperature		T_{STG}	-55~+150	$^\circ\text{C}$	

Notes: 1. Absolute maximum ratings are those values beyond which the device could be permanently damaged.

Absolute maximum ratings are stress ratings only and functional device operation is not implied.

2. Repetitive Rating; Pulse width limited by maximum junction temperature.

3. $L=6.5\text{mH}$, $I_{AS}=15\text{A}$, $V_{DD}=50\text{V}$, $R_G=25\Omega$, Starting $T_J=25^\circ\text{C}$

4. $I_{SD}\leq 15\text{A}$, $di/dt\leq 200\text{A}/\mu\text{s}$, $V_{DD}\leq BV_{DSS}$, Starting $T_J=25^\circ\text{C}$

5. Drain current limited by maximum junction temperature

■ THERMAL DATA

PARAMETER		SYMBOL	RATINGS	UNIT
Junction to Ambient		θ_{JA}	62.5	$^\circ\text{C}/\text{W}$
Junction to Case	TO-220F1	θ_{JC}	2.6	$^\circ\text{C}/\text{W}$
	TO-220F2		2.4	

■ ELECTRICAL CHARACTERISTICS

PARAMETER	SYMBOL	TEST CONDITIONS	MIN	TYP	MAX	UNIT
OFF CHARACTERISTICS						
Drain-Source Breakdown Voltage	BV_{DSS}	$I_D=250\mu A, V_{GS}=0V, T_J=25^\circ C$	500			V
Breakdown Voltage Temperature Coefficient	$\Delta BV_{DSS}/\Delta T_J$	Reference to $25^\circ C, I_D=250\mu A$		0.5		$V/^\circ C$
Drain-Source Leakage Current	I_{DSS}	$V_{DS}=500V, V_{GS}=0V,$			1	μA
		$V_{DS}=320V, T_C=125^\circ C$			10	μA
Gate- Source Leakage Current	Forward	$V_{GS}=+30V, V_{DS}=0V$			+100	nA
	Reverse	$V_{GS}=-30V, V_{DS}=0V$			-100	nA
ON CHARACTERISTICS						
Gate Threshold Voltage	$V_{GS(TH)}$	$V_{GS}=V_{DS}, I_D=250\mu A$	2.0		4.0	V
Static Drain-Source On-State Resistance	$R_{DS(ON)}$	$V_{GS}=10V, I_D=7.5A$		0.3	0.35	Ω
DYNAMIC PARAMETERS						
Input Capacitance	C_{ISS}	$V_{DS}=25V, V_{GS}=0V, f=1.0MHz$		2300	2600	pF
Output Capacitance	C_{OSS}			250	270	pF
Reverse Transfer Capacitance	C_{RSS}			26	30	pF
SWITCHING PARAMETERS						
Total Gate Charge	Q_G	$V_{DS}=320V, V_{GS}=10V, I_D=15A$ (Note 1, 2)		210	240	nC
Gate to Source Charge	Q_{GS}			35		nC
Gate to Drain ("Miller") Charge	Q_{GD}			60		nC
Turn-ON Delay Time	$t_{D(ON)}$	$V_{DD}=200V, I_D=15A, R_G=25\Omega$ (Note 1, 2)		100	120	ns
Rise Time	t_R			150	170	ns
Turn-OFF Delay Time	$t_{D(OFF)}$			460	500	ns
Fall-Time	t_F			180	210	ns
SOURCE- DRAIN DIODE RATINGS AND CHARACTERISTICS						
Maximum Body-Diode Continuous Current	I_S				15	A
Maximum Body-Diode Pulsed Current	I_{SM}				60	A
Drain-Source Diode Forward Voltage	V_{SD}	$I_{SD}=15A, V_{GS}=0V$			1.4	V
Body Diode Reverse Recovery Time	t_{rr}	$I_{SD}=15A, V_{GS}=0V, di_F/dt=100A/\mu s$		333		ns
Body Diode Reverse Recovery Charge	Q_{RR}	(Note 1)		3.24		μC

Notes: 1. Pulse Test: Pulse width $\leq 300\mu s$; Duty Cycle $\leq 2\%$.

2. Essentially Independent of Operating Temperature Typical Characteristics

TEST CIRCUITS AND WAVEFORMS

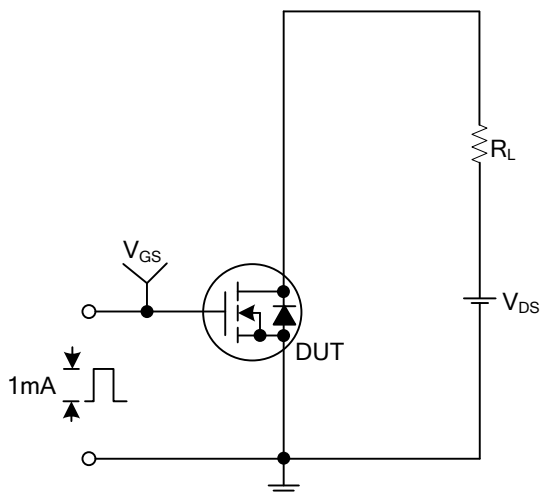

Gate Charge Test Circuit

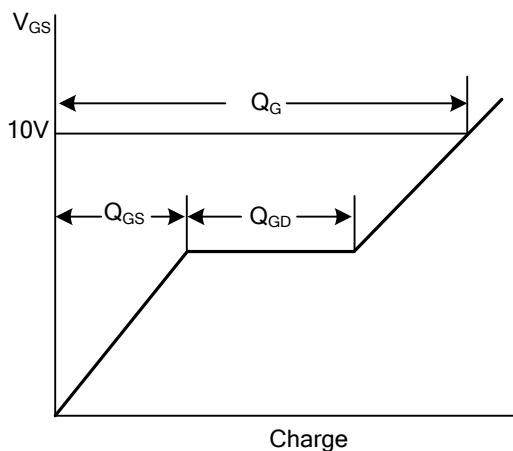

Gate Charge Waveforms

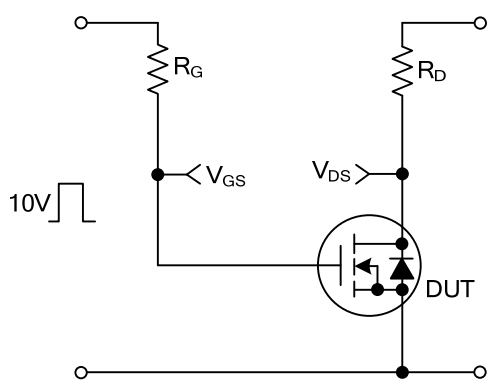

Resistive Switching Test Circuit

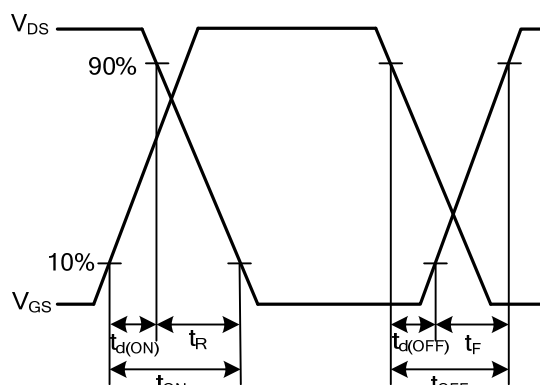

Resistive Switching Waveforms

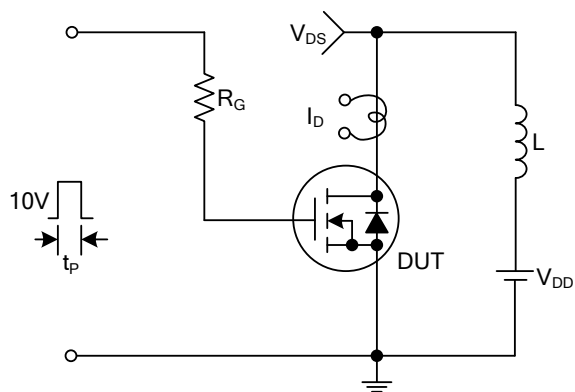

Unclamped Inductive Switching Test Circuit

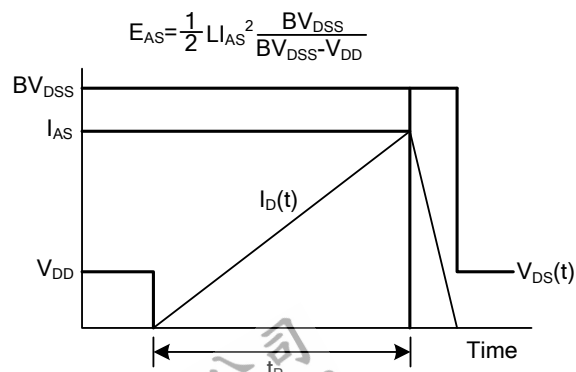

Unclamped Inductive Switching Waveforms

■ TEST CIRCUITS AND WAVEFORMS(Cont.)

Peak Diode Recovery dv/dt Test Circuit & Waveforms

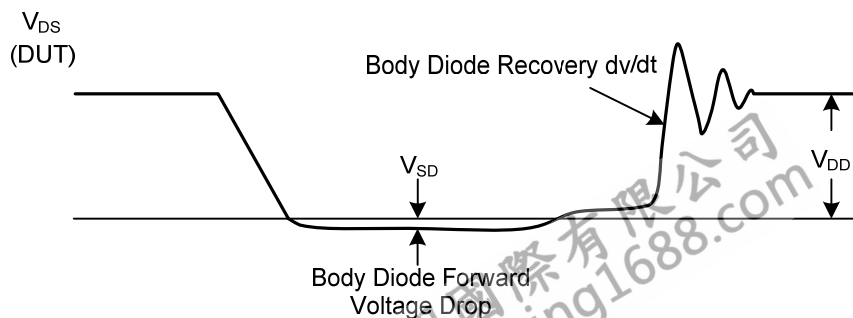
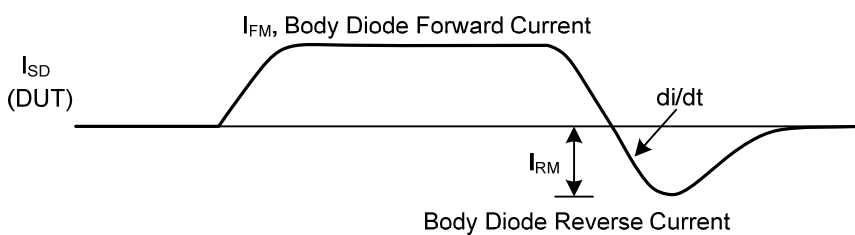
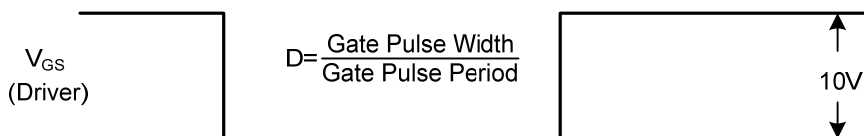
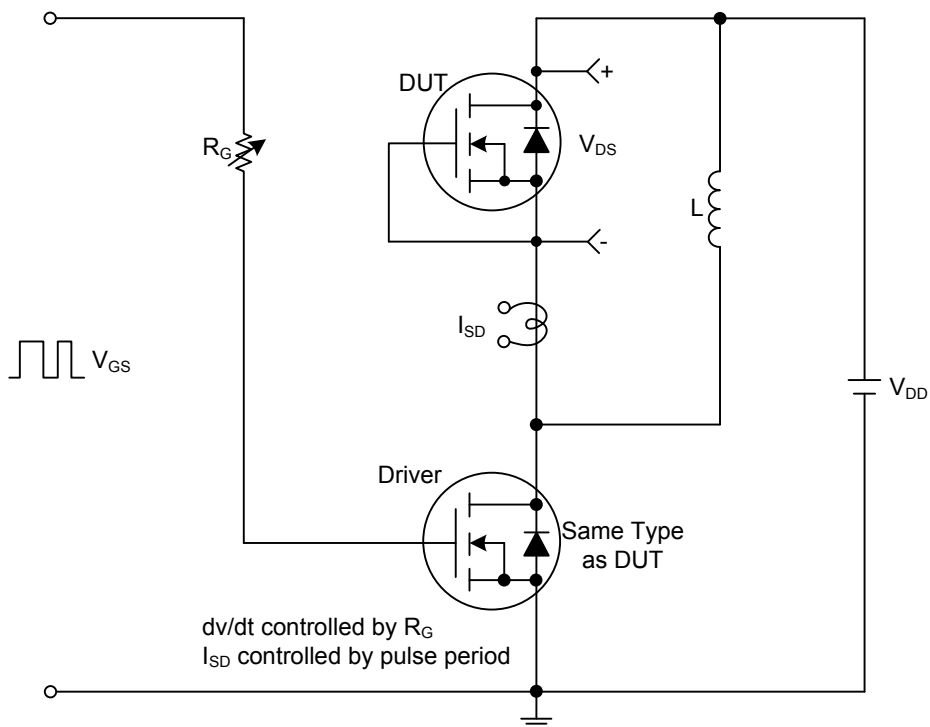

TYPICAL CHARACTERISTICS

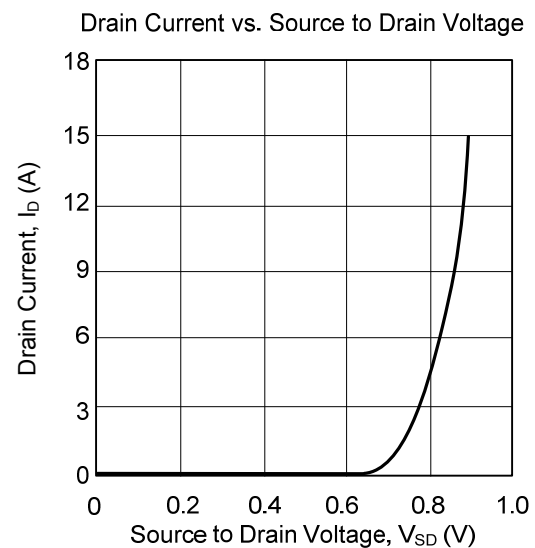
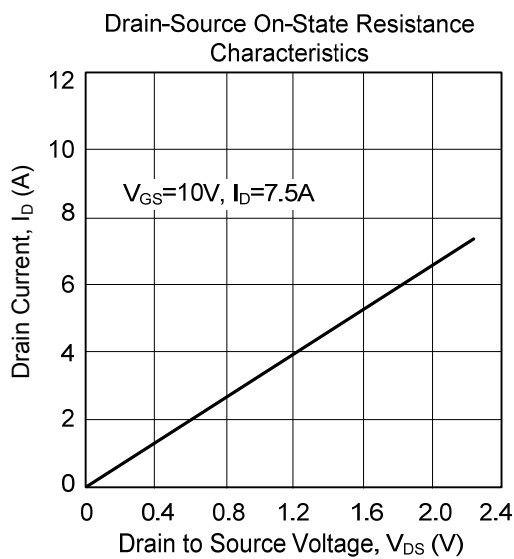
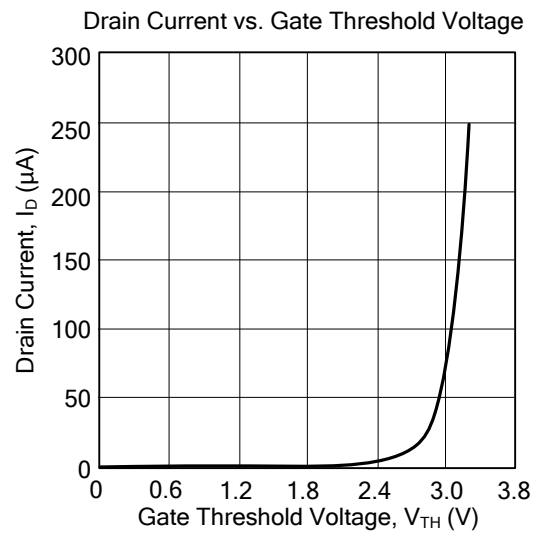
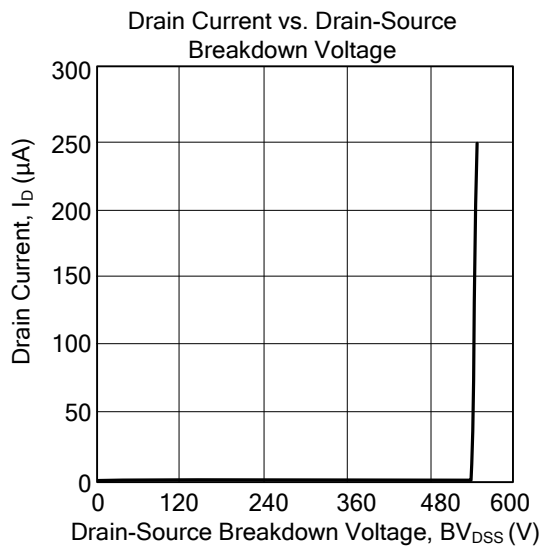

UTC assumes no responsibility for equipment failures that result from using products at values that exceed, even momentarily, rated values (such as maximum ratings, operating condition ranges, or other parameters) listed in products specifications of any and all UTC products described or contained herein. UTC products are not designed for use in life support appliances, devices or systems where malfunction of these products can be reasonably expected to result in personal injury. Reproduction in whole or in part is prohibited without the prior written consent of the copyright owner. The information presented in this document does not form part of any quotation or contract, is believed to be accurate and reliable and may be changed without notice.