



## 17P10-Q

Preliminary

Power MOSFET

### -17A, -100V P-CHANNEL POWER MOSFET

#### DESCRIPTION

The **17P10-Q** uses advanced proprietary, planar stripe, DMOS technology to provide excellent  $R_{DS(ON)}$ , low gate charge and operation with low gate voltages. This device is suitable to be used in low voltage applications such as audio amplifier, high efficiency switching DC/DC converters, and DC motor control.

#### FEATURES

- \*  $R_{DS(ON)} < 0.19\Omega$  @  $V_{GS}=-10V$ ,  $I_D=-8.5A$
- \* Low capacitance
- \* Low gate charge
- \* Fast switching capability
- \* Avalanche energy specified

#### SYMBOL

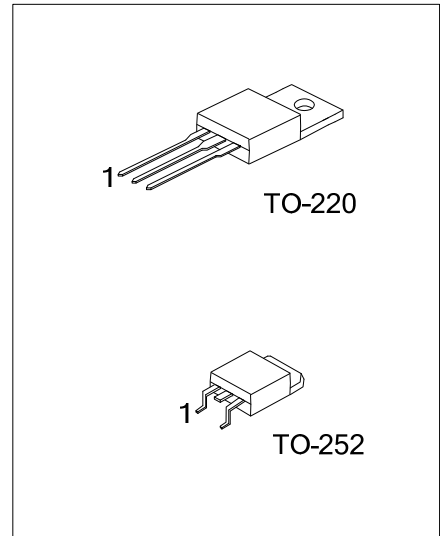
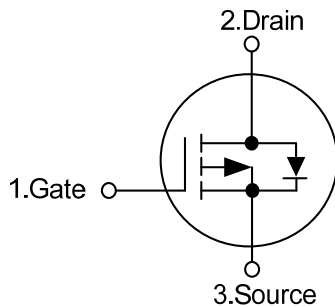

#### ORDERING INFORMATION

Ordering Number		Package	Pin Assignment			Packing
Lead Free	Halogen Free		1	2	3	
17P10L-TA3-T	17P10G-TA3-T	TO-220	G	D	S	Tube
17P10L-TN3-R	17P10G-TN3-R	TO-252	G	D	S	Tape Reel

Note: Pin Assignment: G: Gate D: Drain S: Source

	<p>(1) T: Tube, R: Tape Reel</p> <p>(2) TA3: TO-220, TN3: TO-252</p> <p>(3) G: Halogen Free and Lead Free, L: Lead Free</p>
--	---

#### MARKING

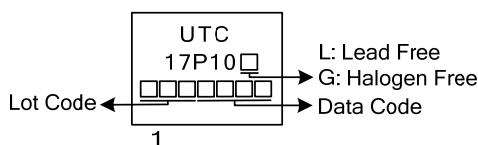

■ ABSOLUTE MAXIMUM RATINGS ( $T_C=25^{\circ}\text{C}$ , unless otherwise specified)

PARAMETER	SYMBOL	RATINGS	UNIT
Drain-Source Voltage	$V_{DSS}$	-100	V
Gate-Source Voltage	$V_{GSS}$	$\pm 30$	V
Continuous Drain Current	$I_D$	-17	A
Pulsed Drain Current (Note 2)	$I_{DM}$	-68	A
Avalanche Current (Note 2)	$I_{AR}$	-17	A
Single Pulsed Avalanche Energy (Note 3)	$E_{AS}$	318	mJ
Peak Diode Recovery dv/dt	dv/dt	21	V/ns
Power Dissipation	TO-220	100	W
	TO-252	70	W
Junction Temperature	$T_J$	+150	$^{\circ}\text{C}$
Storage Temperature	$T_{STG}$	-55 ~ +150	$^{\circ}\text{C}$

Notes: 1. Absolute maximum ratings are those values beyond which the device could be permanently damaged.

Absolute maximum ratings are stress ratings only and functional device operation is not implied.

2. Repetitive Rating : Pulse width limited by maximum junction temperature.

3.  $L=3.2\text{mH}$ ,  $I_{AS}=-14\text{A}$ ,  $V_{DD}=-50\text{V}$ ,  $R_G=25\Omega$ , Starting  $T_J=25^{\circ}\text{C}$

4.  $I_{SD}\leq -17\text{A}$ ,  $di/dt \leq 200\mu\text{A/s}$ ,  $V_{DD}\leq BV_{DSS}$ , Starting  $T_J=25^{\circ}\text{C}$

■ THERMAL DATA

PARAMETER	SYMBOL	RATING	UNIT
Junction to Ambient	TO-220	62.5	$^{\circ}\text{C/W}$
	TO-252	110	
Junction to Case	TO-220	1.25	$^{\circ}\text{C/W}$
	TO-252	1.78	

■ ELECTRICAL CHARACTERISTICS ( $T_c=25^\circ\text{C}$ , unless otherwise specified)

PARAMETER	SYMBOL	TEST CONDITIONS	MIN	TYP	MAX	UNIT
<b>OFF CHARACTERISTICS</b>						
Drain-Source Breakdown Voltage	$BV_{DSS}$	$V_{GS}=0\text{ V}, I_D=-250\mu\text{A}$	-100			V
Drain-Source Leakage Current	$I_{DSS}$	$V_{DS}=-100\text{V}, V_{GS}=0\text{V}$			-1	$\mu\text{A}$
Gate-Source Leakage Current	$I_{GSS}$	$V_{DS}=0\text{V}, V_{GS}=\pm 30\text{V}$			$\pm 100$	nA
<b>ON CHARACTERISTICS</b>						
Gate Threshold Voltage	$V_{GS(TH)}$	$V_{DS}=V_{GS}, I_D=-250\mu\text{A}$	-2.0		-4.0	V
Static Drain-Source On-Resistance	$R_{DS(ON)}$	$V_{GS}=-10\text{V}, I_D=-8.5\text{A}$			0.19	$\Omega$
<b>DYNAMIC PARAMETERS</b>						
Input Capacitance	$C_{ISS}$	$V_{DS}=-25\text{V}, V_{GS}=0\text{V}, f=1.0\text{MHz}$		625		pF
Output Capacitance	$C_{OSS}$			190		pF
Reverse Transfer Capacitance	$C_{RSS}$			60		pF
<b>SWITCHING PARAMETERS</b>						
Total Gate Charge	$Q_G$	$V_{DS}=-50\text{V}, V_{GS}=-10\text{V}, I_D=-1.3\text{A}$ $I_G=-100\mu\text{A}$ (Note 1, 2)		58		nC
Gate Source Charge	$Q_{GS}$			5.4		nC
Gate Drain Charge	$Q_{GD}$			8		nC
Turn-ON Delay Time	$t_{D(ON)}$	$V_{DD}=-30\text{V}, V_{GS}=-10\text{V}, I_D=-0.5\text{A},$ $R_G=25\Omega$ (Note 1, 2)		52		ns
Turn-ON Rise Time	$t_R$			68		ns
Turn-OFF Delay Time	$t_{D(OFF)}$			240		ns
Turn-OFF Fall-Time	$t_F$			88		ns
<b>SOURCE- DRAIN DIODE RATINGS AND CHARACTERISTICS</b>						
Maximum Body-Diode Continuous Current	$I_S$				-17	A
Maximum Pulsed Drain-Source Diode Forward Current	$I_{SM}$				-68	A
Diode Forward Voltage	$V_{SD}$	$V_{GS}=0\text{V}, I_S=-17\text{A}$			-5	V
Body Diode Reverse Recovery Time	$t_{rr}$	$V_{GS}=0\text{V}, I_S=-17\text{A},$ $dI_F/dt=100\text{A}/\mu\text{s}$ (Note 1)		112		ns
Body Diode Reverse Recovery Charge	$Q_{rr}$			0.44		$\mu\text{C}$

Notes: 1. Pulse Test : Pulse width  $\leq 300\mu\text{s}$ , Duty cycle  $\leq 2\%$ .

2. Essentially independent of operating temperature.

■ TEST CIRCUITS AND WAVEFORMS

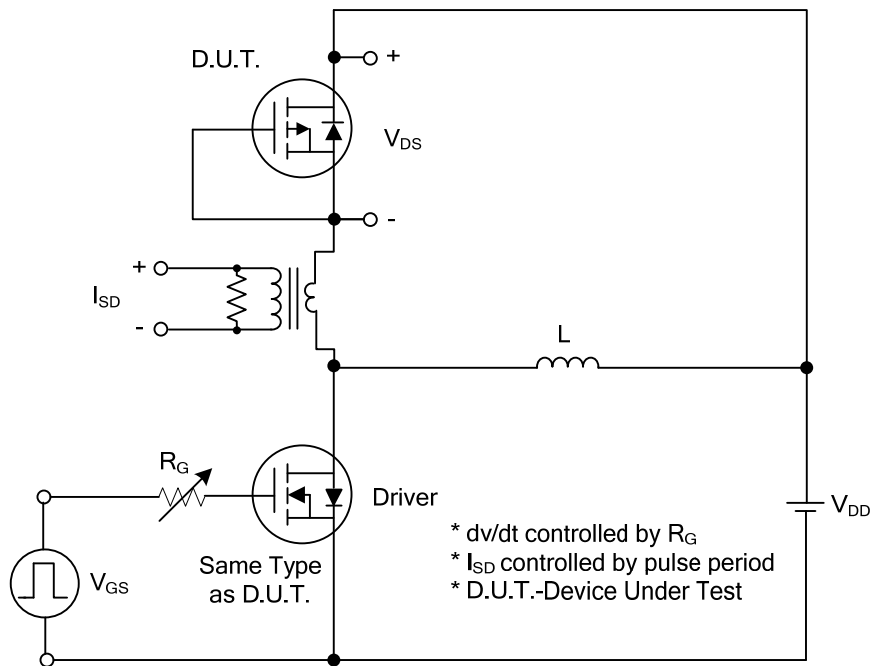

Peak Diode Recovery  $dv/dt$  Test Circuit

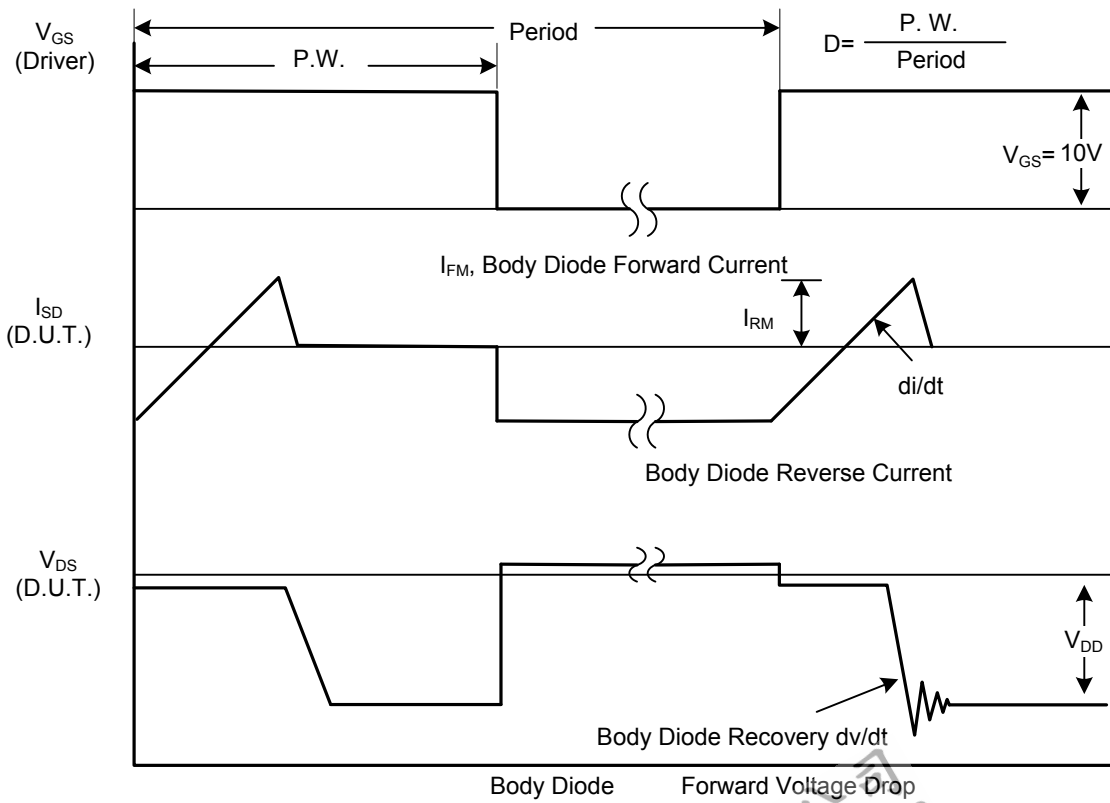

Peak Diode Recovery  $dv/dt$  Waveforms

■ TEST CIRCUITS AND WAVEFORMS (Cont.)

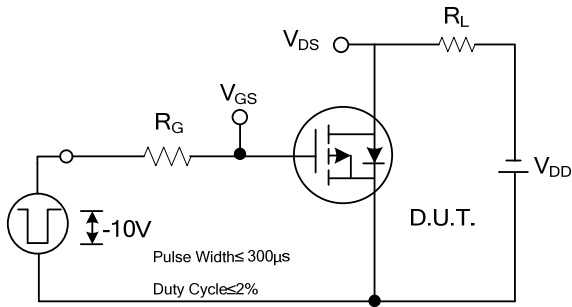

Switching Test Circuit

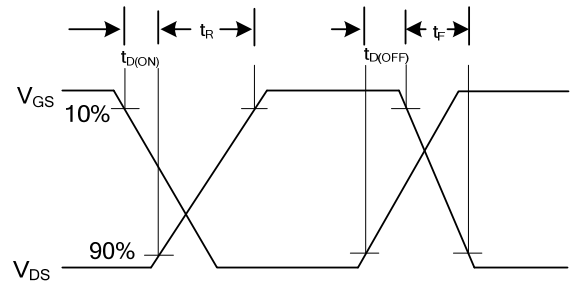

Switching Waveforms

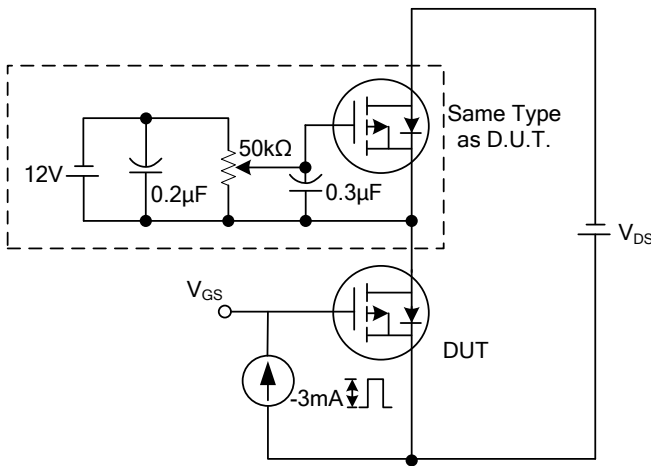

Gate Charge Test Circuit

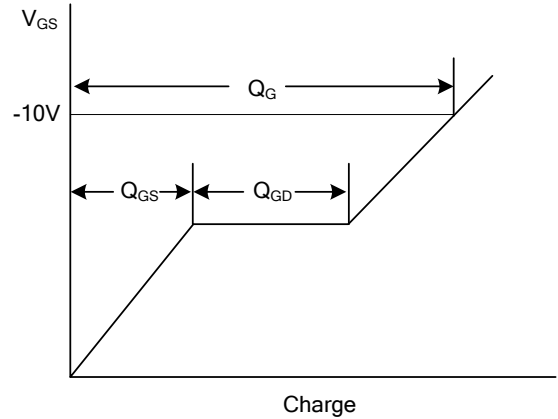

Gate Charge Waveform

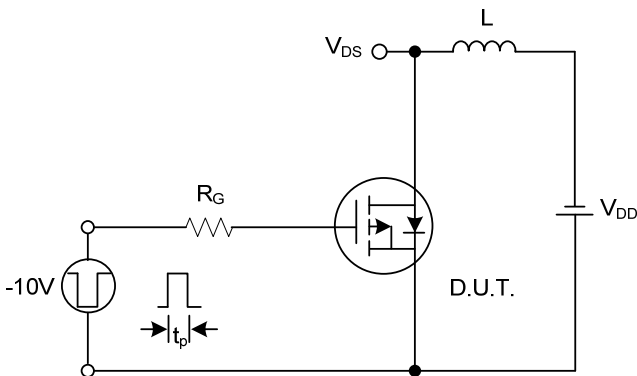

Unclamped Inductive Switching Test Circuit

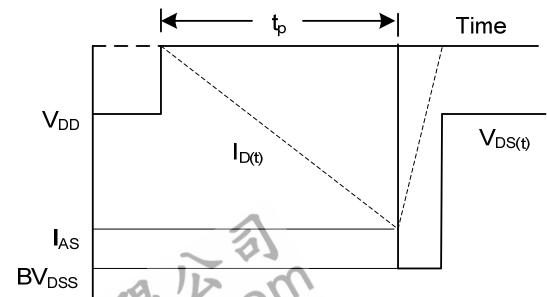

Unclamped Inductive Switching Waveforms

UTC assumes no responsibility for equipment failures that result from using products at values that exceed, even momentarily, rated values (such as maximum ratings, operating condition ranges, or other parameters) listed in products specifications of any and all UTC products described or contained herein. UTC products are not designed for use in life support appliances, devices or systems where malfunction of these products can be reasonably expected to result in personal injury. Reproduction in whole or in part is prohibited without the prior written consent of the copyright owner. The information presented in this document does not form part of any quotation or contract, is believed to be accurate and reliable and may be changed without notice.