



1N60-KW

Power MOSFET

1A, 600V N-CHANNEL POWER MOSFET

DESCRIPTION

The UTC 1N60-KW is a high voltage MOSFET and is designed to have better characteristics, such as fast switching time, low gate charge, low on-state resistance and have a high rugged avalanche characteristics. This power MOSFET is usually used at high speed switching applications in power supplies, PWM motor controls, high efficient AC to DC converters and bridge circuits.

FEATURES

- * $R_{DS(ON)} \leq 15\Omega @ V_{GS}=10V, I_D=0.5A$
- * Fast switching capability
- * Avalanche energy specified
- * Improved dv/dt capability, high ruggedness

SYMBOL

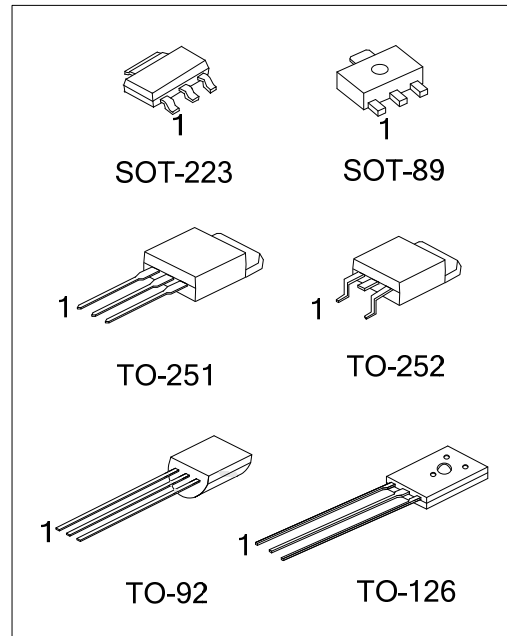
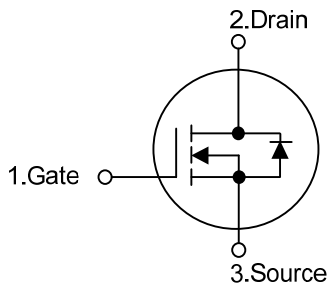

ORDERING INFORMATION

Ordering Number		Package	Pin Assignment			Packing
Lead Free	Halogen Free		1	2	3	
1N60L-AA3-R	1N60G-AA3-R	SOT-223	G	D	S	Tape Reel
1N60L-AB3-R	1N60G-AB3-R	SOT-89	G	D	S	Tape Reel
1N60L-TM3-T	1N60G-TM3-T	TO-251	G	D	S	Tube
1N60L-TN3-R	1N60G-TN3-R	TO-252	G	D	S	Tape Reel
1N60L-T60-K	1N60G-T60-K	TO-126	G	D	S	Bulk
1N60L-T92-B	1N60G-T92-B	TO-92	G	D	S	Tape Box
1N60L-T92-K	1N60G-T92-K	TO-92	G	D	S	Bulk

Note: Pin Assignment: G: Gate D: Drain S: Source

<p>1N60G-AA3-R</p>	<p>(1) T: Tube, R: Tape Reel, B: Tape Box, K: Bulk (2) AA3: SOT-223, AB3: SOT-89, TM3: TO-251 TN3: TO-252, T60: TO-126, T92: TO-92 (3) G: Halogen Free and Lead Free, L: Lead Free</p>
--------------------	---

MARKING

PACKAGE	MARKING
SOT-223	<p>1N60 □ Lot Code ← □ □ □ □ → Date Code 1 L: Lead Free G: Halogen Free</p>
SOT-89	<p>□ □ □ □ □ □ □ □ → Lot Code □ □ □ □ □ □ □ □ → Date Code 1N60 □ 1 L: Lead Free G: Halogen Free</p>
TO-251 / TO-252	<p>UTC 1N60 □ Lot Code ← □ □ □ □ □ □ □ □ → Date Code 1 L: Lead Free G: Halogen Free</p>
TO-126	<p>UTC □ □ □ □ □ □ □ □ → Date Code L: Lead Free ← □ □ □ □ □ □ □ □ → Lot Code G: Halogen Free 1N60 □ □ □ □ 1</p>
TO-92	<p>UTC 1N60 □ Lot Code ← □ □ □ □ □ □ □ □ → Date Code 1 L: Lead Free G: Halogen Free</p>

汎翔國際有限公司
 www.flying1688.com

■ **ABSOLUTE MAXIMUM RATINGS** ($T_C = 25^\circ\text{C}$, unless otherwise specified)

PARAMETER		SYMBOL	RATINGS	UNIT
Drain-Source Voltage		V_{DSS}	600	V
Gate-Source Voltage		V_{GSS}	± 30	V
Continuous Drain Current		I_D	1	A
Avalanche Energy	Single Pulsed (Note 2)	E_{AS}	7.2	mJ
Peak Diode Recovery dv/dt (Note 3)		dv/dt	4.5	V/ns
Power Dissipation ($T_A=25^\circ\text{C}$)	SOT-89	P_D	8	W
	SOT-223		8	W
	TO-251/TO-252		27	W
	TO-126/TO-92		12.5	W
Junction Temperature		T_J	+150	$^\circ\text{C}$
Operating Temperature		T_{OPR}	-55 ~ +150	$^\circ\text{C}$
Storage Temperature		T_{STG}	-55 ~ +150	$^\circ\text{C}$

Notes: 1. Absolute maximum ratings are those values beyond which the device could be permanently damaged.

Absolute maximum ratings are stress ratings only and functional device operation is not implied.

2. $L = 10\text{mH}$, $I_{AS} = 1.2\text{A}$, $V_{DD} = 50\text{V}$, $R_G = 25\Omega$, Starting $T_J = 25^\circ\text{C}$

3. $I_{SD} \leq 1.2\text{A}$, $di/dt \leq 200\text{A}/\mu\text{s}$, $V_{DD} \leq BV_{DSS}$, Starting $T_J = 25^\circ\text{C}$

■ **THERMAL DATA**

PARAMETER		SYMBOL	RATINGS	UNIT
Junction to Ambient	SOT-89/SOT-223	θ_{JA}	150	$^\circ\text{C}/\text{W}$
	TO-251/TO-252		100	$^\circ\text{C}/\text{W}$
	TO-126/TO-92		132	$^\circ\text{C}/\text{W}$
Junction to Case	SOT-89/SOT-223	θ_{JC}	15.6	$^\circ\text{C}/\text{W}$
	TO-251/TO-252		4.6	$^\circ\text{C}/\text{W}$
	TO-126/TO-92		10	$^\circ\text{C}/\text{W}$

■ **ELECTRICAL CHARACTERISTICS** ($T_C=25^\circ\text{C}$, unless otherwise specified.)

PARAMETER	SYMBOL	TEST CONDITIONS	MIN	TYP	MAX	UNIT
OFF CHARACTERISTICS						
Drain-Source Breakdown Voltage	BV_{DSS}	$V_{GS}=0V, I_D=250\mu A$	600			V
Drain-Source Leakage Current	I_{DSS}	$V_{DS}=600V, V_{GS}=0V$			10	μA
Gate-Source Leakage Current	Forward	I_{GSS}			100	nA
	Reverse					
ON CHARACTERISTICS						
Gate Threshold Voltage	$V_{GS(TH)}$	$V_{DS}=V_{GS}, I_D=250\mu A$	2.0		4.0	V
Static Drain-Source On-State Resistance	$R_{DS(ON)}$	$V_{GS}=10V, I_D=0.5A$		12	15	Ω
DYNAMIC CHARACTERISTICS						
Input Capacitance	C_{ISS}	$V_{DS}=25V, V_{GS}=0V, f=1\text{MHz}$		115		pF
Output Capacitance	C_{OSS}			17.5		pF
Reverse Transfer Capacitance	C_{RSS}			2		pF
SWITCHING CHARACTERISTICS						
Total Gate Charge	Q_G	$V_{DS}=480V, V_{GS}=10V, I_D=1A$ (Note 2,3)		7.5		nC
Gate-Source Charge	Q_{GS}			3.2		nC
Gate-Drain Charge	Q_{GD}			0.6		nC
Turn-On Delay Time	$t_{D(ON)}$	$V_{DD}=100V, V_{GS}=10V, I_D=1A,$ $R_G=25\Omega, \text{(Note 2,3)}$		2.4		ns
Turn-On Rise Time	t_R			15		ns
Turn-Off Delay Time	$t_{D(OFF)}$			9.6		ns
Turn-Off Fall Time	t_F			35		ns
SOURCE-DRAIN DIODE RATINGS AND CHARACTERISTICS						
Maximum Continuous Drain-Source Diode Forward Current	I_S				1	A
Maximum Pulsed Drain-Source Diode Forward Current	I_{SM}				2	A
Drain-Source Diode Forward Voltage	V_{SD}	$I_S=1A, V_{GS}=0V$			1.4	V
Reverse Recovery Time	t_{rr}	$I_S=1A, V_{GS}=0V$ $dI_F/dt=100A/\mu s \text{ (Note 1)}$		280		ns
Reverse Recovery Charge	Q_{rr}			400		nC

Notes: 1. Repetitive Rating: Pulse width limited by maximum junction temperature.

2. Pulse Test: Pulse Width $\leq 300\mu s$, Duty Cycle $\leq 2\%$.

3. Essentially Independent of Operating Temperature.

■ TEST CIRCUITS AND WAVEFORMS

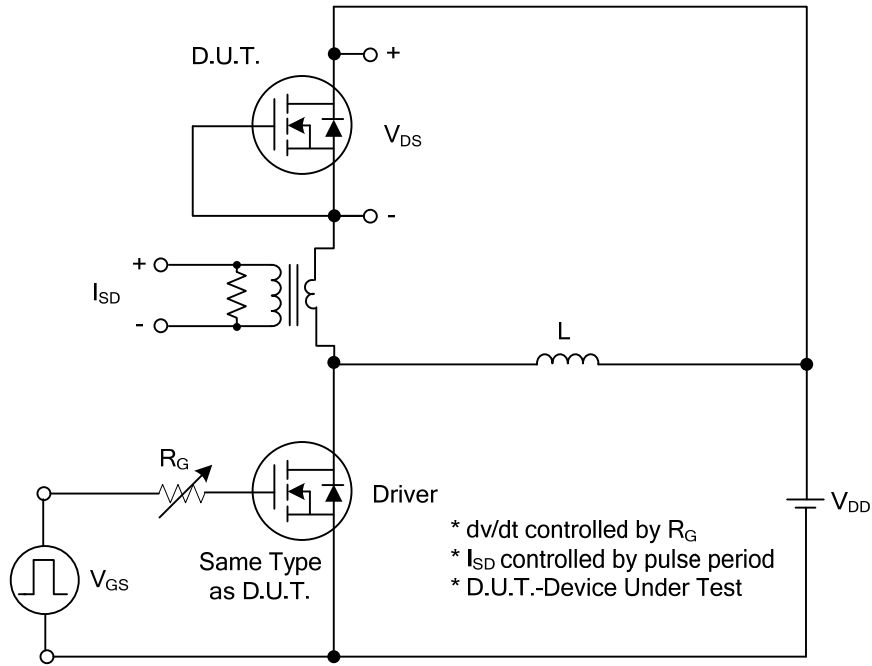

Peak Diode Recovery dv/dt Test Circuit

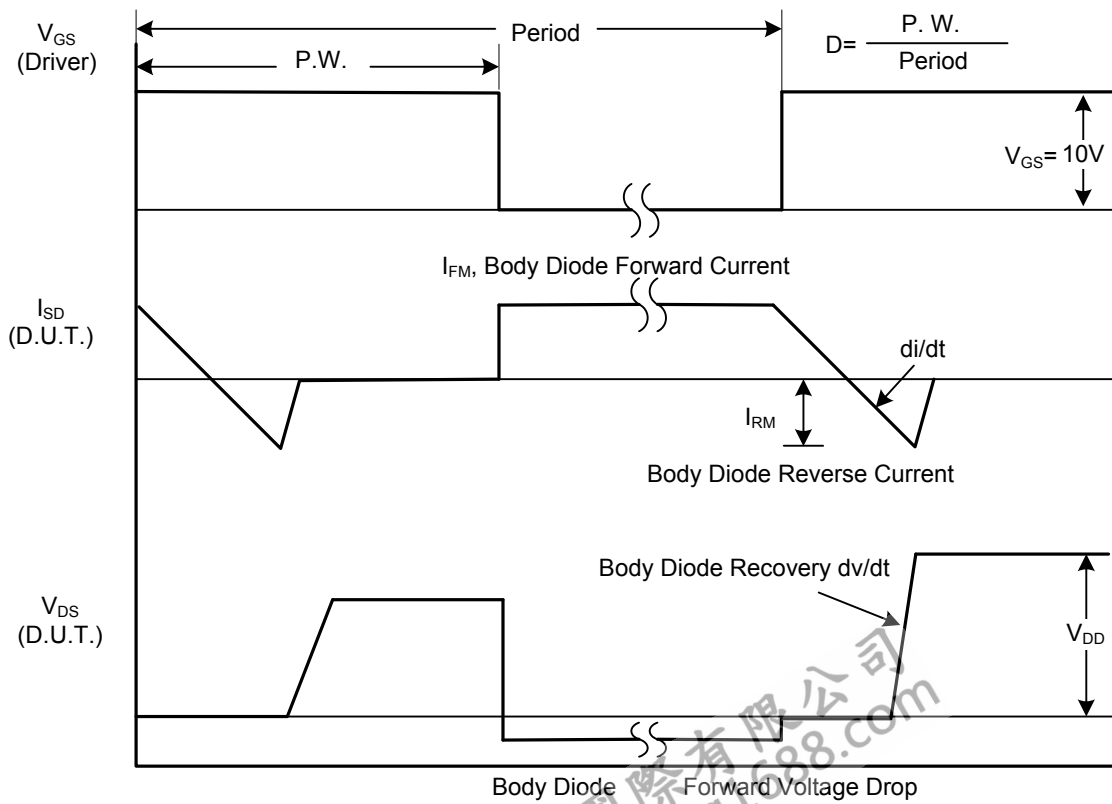

Peak Diode Recovery dv/dt Waveforms

TEST CIRCUITS AND WAVEFORMS

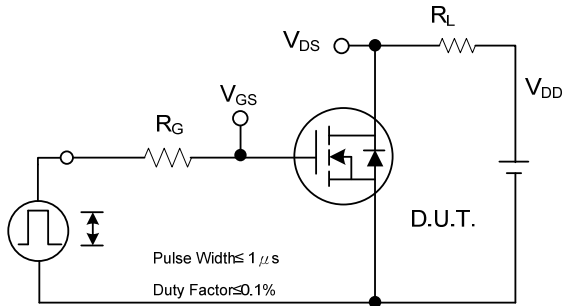

Switching Test Circuit

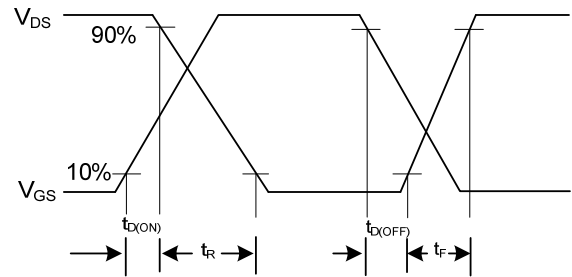

Switching Waveforms

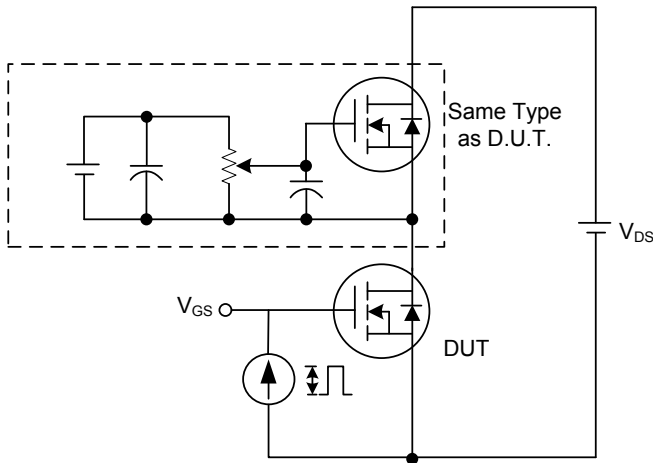

Gate Charge Test Circuit

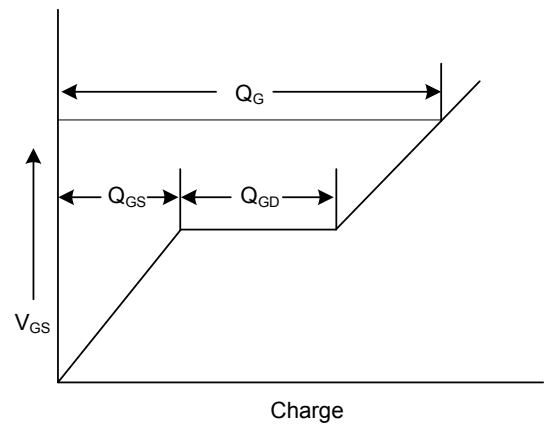

Gate Charge Waveform

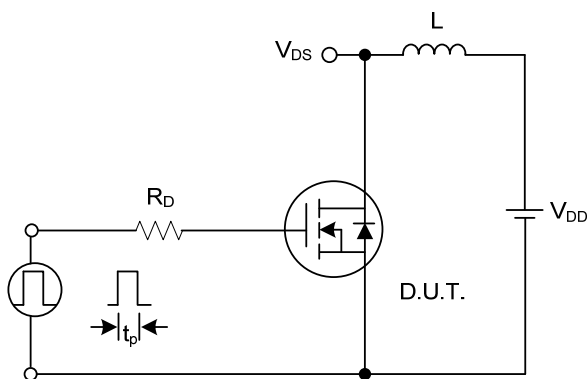

Unclamped Inductive Switching Test Circuit

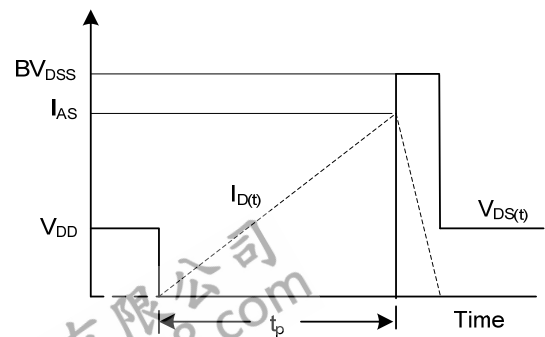

Unclamped Inductive Switching Waveforms

TYPICAL CHARACTERISTICS

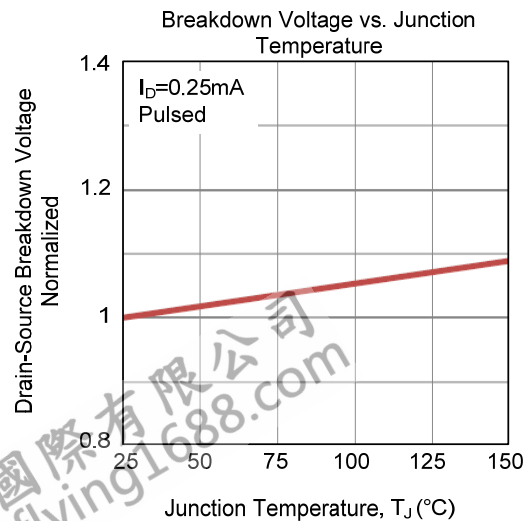
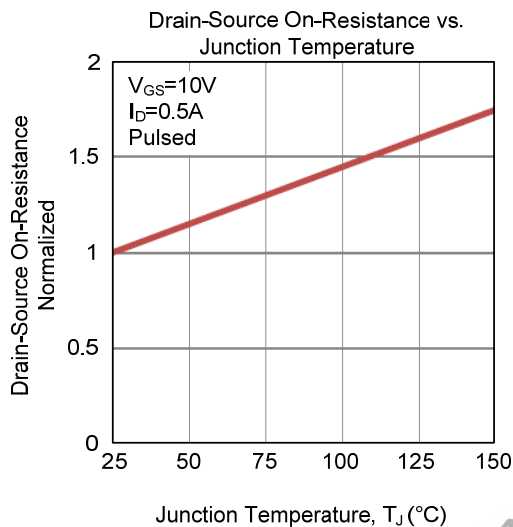
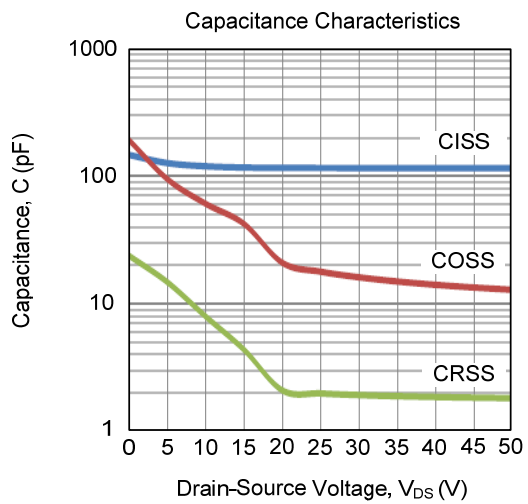
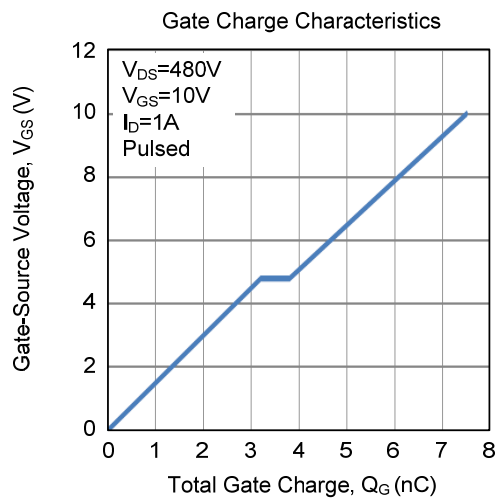
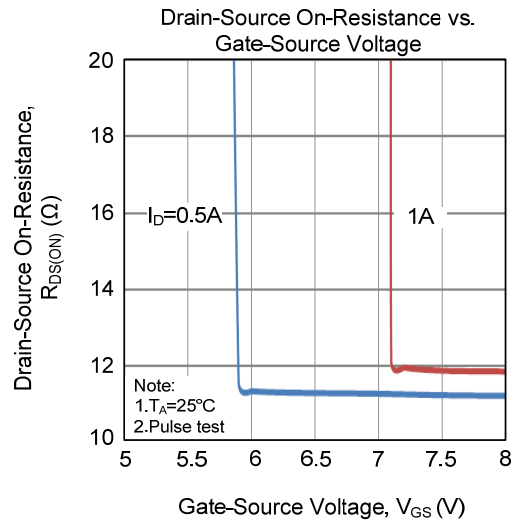
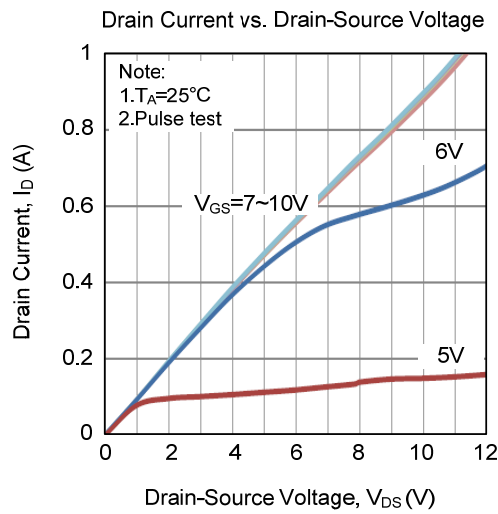

■ TYPICAL CHARACTERISTICS (Cont.)

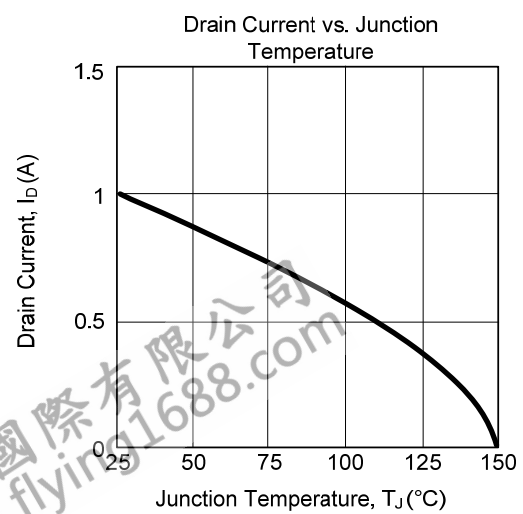
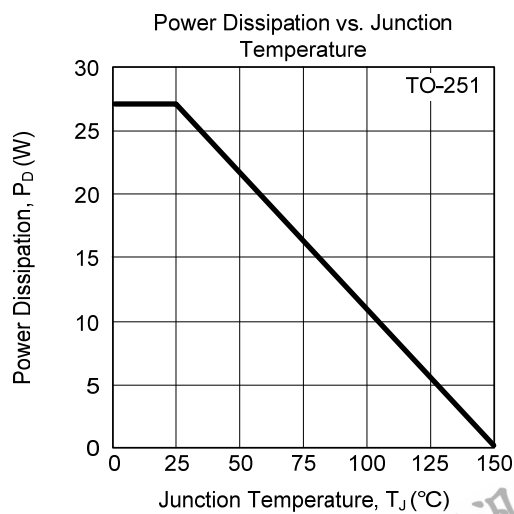
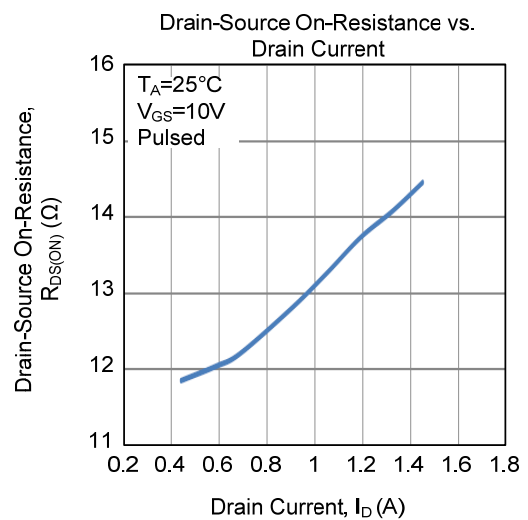
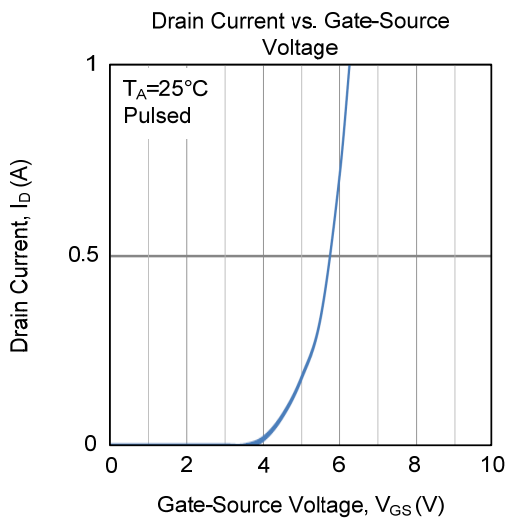
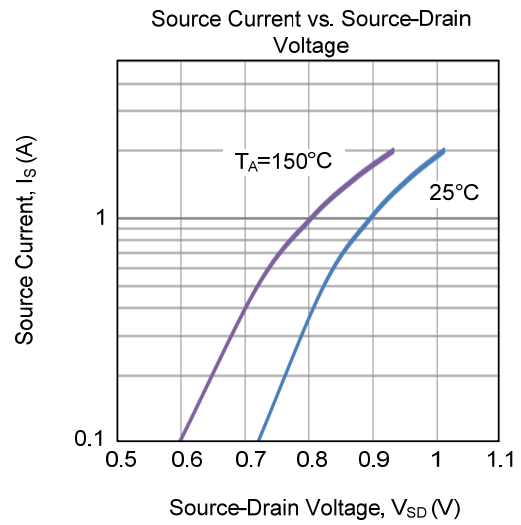
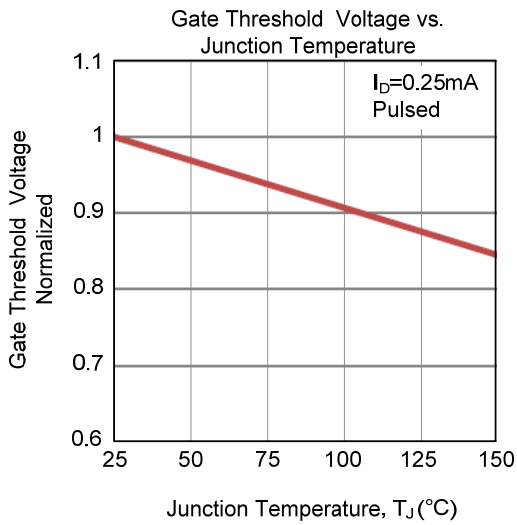

■ **TYPICAL CHARACTERISTICS (Cont.)**

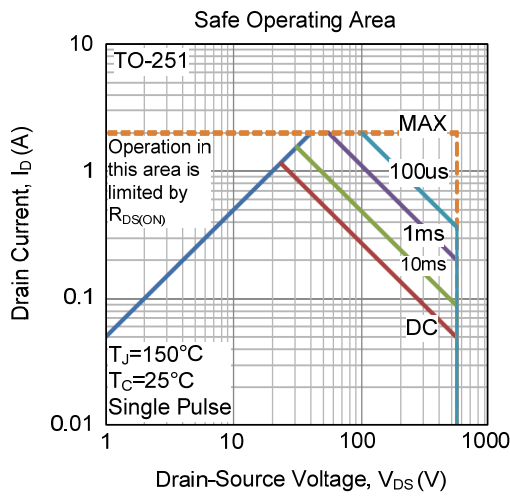

UTC assumes no responsibility for equipment failures that result from using products at values that exceed, even momentarily, rated values (such as maximum ratings, operating condition ranges, or other parameters) listed in products specifications of any and all UTC products described or contained herein. UTC products are not designed for use in life support appliances, devices or systems where malfunction of these products can be reasonably expected to result in personal injury. Reproduction in whole or in part is prohibited without the prior written consent of the copyright owner. UTC reserves the right to make changes to information published in this document, including without limitation specifications and product descriptions, at any time and without notice. This document supersedes and replaces all information supplied prior to the publication hereof.