



1N65-CBS

Preliminary

Power MOSFET

1.0A, 650V N-CHANNEL POWER MOSFET

DESCRIPTION

The UTC **1N65-CBS** is a high voltage power MOSFET and is designed to have better characteristics, such as fast switching time, low gate charge, low on-state resistance and have a high rugged avalanche characteristics. This power MOSFET is usually used at high speed switching applications in power supplies, PWM motor controls, high efficient DC to DC converters and bridge circuits.

FEATURES

- * $R_{DS(ON)} < 12.5\Omega @ V_{GS} = 10V, I_D = 0.5A$
- * Fast switching capability
- * Avalanche energy specified
- * Improved dv/dt capability, high ruggedness

SYMBOL

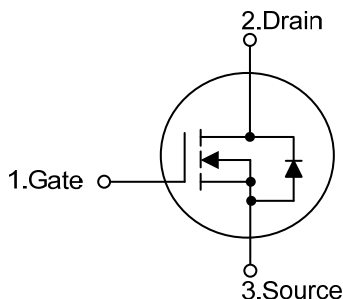

ORDERING INFORMATION

Ordering Number		Package	Pin Assignment			Packing
Lead Free	Halogen Free		1	2	3	
-	1N65G-AA3-R	SOT-223	G	D	S	Tape Reel
1N65L-TM3-T	1N65G-TM3-T	TO-251	G	D	S	Tube
1N65L-TN3-R	1N65G-TN3-R	TO-252	G	D	S	Tape Reel
1N65L-T92-B	1N65G-T92-B	TO-92	G	D	S	Tape Box
1N65L-T92-K	1N65G-T92-K	TO-92	G	D	S	Bulk

Note: Pin Assignment: G: Gate D: Drain S: Source

<p>1N65G-AA3-R</p> <p>(1)Packing Type</p> <p>(2)Package Type</p> <p>(3)Green Package</p>	<p>(1) B: Tape Box, K: Bulk, T: Tube, R: Tape Reel</p> <p>(2) AA3: SOT-223, TM3: TO-251, TN3: TO-252, T92: TO-92</p> <p>(3) L: Lead Free, G: Halogen Free and Lead Free</p>
--	---

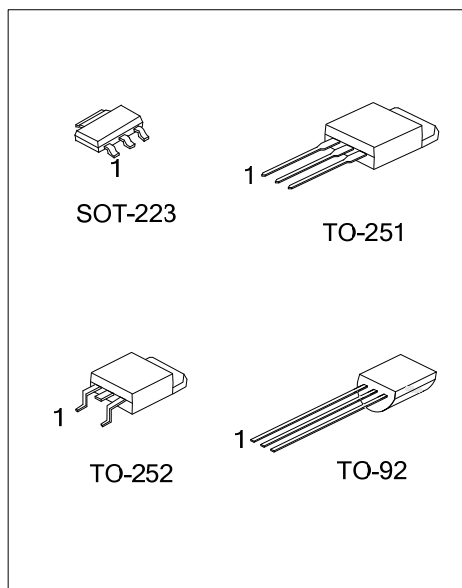

MARKING

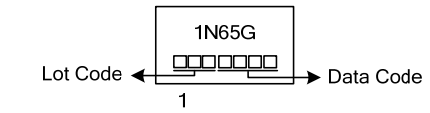
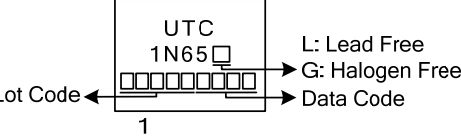
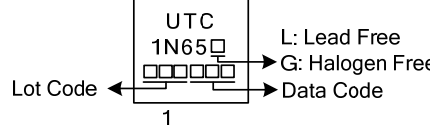
PACKAGE	MARKING
SOT-223	
TO-251 / TO-252	
TO-92	

FLYING 汎翔國際有限公司
 www.flying1688.com

■ ABSOLUTE MAXIMUM RATINGS (T_C=25°C, unless otherwise specified)

PARAMETER		SYMBOL	RATINGS	UNIT
Drain-Source Voltage		V _{DSS}	650	V
Gate-Source Voltage		V _{GSS}	±30	V
Drain Current	Continuous	I _D	1.0	A
	Pulsed (Note 2)	I _{DM}	4.0	A
Avalanche Current (Note 3)		I _{AR}	1.4	A
Avalanche Energy	Single Pulsed (Note 3)	E _{AS}	10	mJ
Peak Diode Recovery dv/dt (Note 4)		dv/dt	3.9	V/ns
Power Dissipation	SOT-223	P _D	8	W
	TO-251/TO-252		28	W
	TO-92		1.5	W
Junction Temperature		T _J	+150	°C
Storage Temperature		T _{STG}	-55 ~ +150	°C

Notes: 1. Absolute maximum ratings are those values beyond which the device could be permanently damaged.

Absolute maximum ratings are stress ratings only and functional device operation is not implied.

2. Repetitive Rating: Pulse width limited by maximum junction temperature.

3. L=10mH, I_{AS}=1.4A, V_{DD}=50V, R_G=25 Ω, Starting T_J = 25°C

4. I_{SD} ≤ 1.0A, di/dt ≤ 200A/μs, V_{DD} ≤ BV_{DSS}, Starting T_J = 25°C

■ THERMAL DATA

PARAMETER		SYMBOL	RATINGS	UNIT
Junction to Ambient	SOT-223	θ _{JA}	150	°C/W
	TO-251/TO-252		110	°C/W
	TO-92		140	°C/W
Junction to Case	SOT-223	θ _{JC}	15.6	°C/W
	TO-251/TO-252		4.46	°C/W
	TO-92		83.3	°C/W

■ ELECTRICAL CHARACTERISTICS (T_J=25°C, unless otherwise specified)

PARAMETER	SYMBOL	TEST CONDITIONS	MIN	TYP	MAX	UNIT
OFF CHARACTERISTICS						
Drain-Source Breakdown Voltage	BV _{DSS}	V _{GS} =0V, I _D =250μA	650			V
Drain-Source Leakage Current	I _{DSS}	V _{DS} =650V, V _{GS} =0V			1	μA
Gate- Source Leakage Current	Forward	I _{GSS}			100	nA
	Reverse					
ON CHARACTERISTICS						
Gate Threshold Voltage	V _{GS(TH)}	V _{DS} =V _{GS} , I _D =250μA	2.0		4.0	V
Static Drain-Source On-State Resistance	R _{DS(ON)}	V _{GS} =10V, I _D =0.5A			12.5	Ω
DYNAMIC CHARACTERISTICS						
Input Capacitance	C _{ISS}	V _{DS} =25V, V _{GS} =0V, f=1.0 MHz		155		pF
Output Capacitance	C _{OSS}			30		pF
Reverse Transfer Capacitance	C _{RSS}			14		pF
SWITCHING CHARACTERISTICS						
Total Gate Charge (Note 1)	Q _G	V _{DS} =30V, V _{GS} =10V, I _D =0.5A I _G =100μA (Note 1, 2)		13		nC
Gate to Source Charge	Q _{GS}			1.5		nC
Gate to Drain Charge	Q _{GD}			1.3		nC
Turn-ON Delay Time (Note 1)	t _{D(ON)}	V _{DD} =30V, V _{GS} =10V, I _D =0.5A R _G =25Ω (Note 1, 2)		37		ns
Rise Time	t _R			15		ns
Turn-OFF Delay Time	t _{D(OFF)}			71		ns
Fall-Time	t _F			12		ns
DRAIN-SOURCE DIODE CHARACTERISTICS AND MAXIMUM RATINGS						
Maximum Body-Diode Continuous Current	I _S				1.0	A
Maximum Body-Diode Pulsed Current (Note 1)	I _{SM}				4.0	A
Drain-Source Diode Forward Voltage (Note 1)	V _{SD}	I _S =1.0A, V _{GS} =0V			1.4	V
Body Diode Reverse Recovery Time	t _{rr}	I _S =1.0A, V _{GS} =0V, di/dt=100A/μs		265		ns
Body Diode Reverse Recovery Charge	Q _{rr}			0.42		μC

Notes: 1. Pulse Test: Pulse width ≤ 300μs, Duty cycle ≤ 2%.

2. Essentially independent of operating temperature.

■ TEST CIRCUITS AND WAVEFORMS

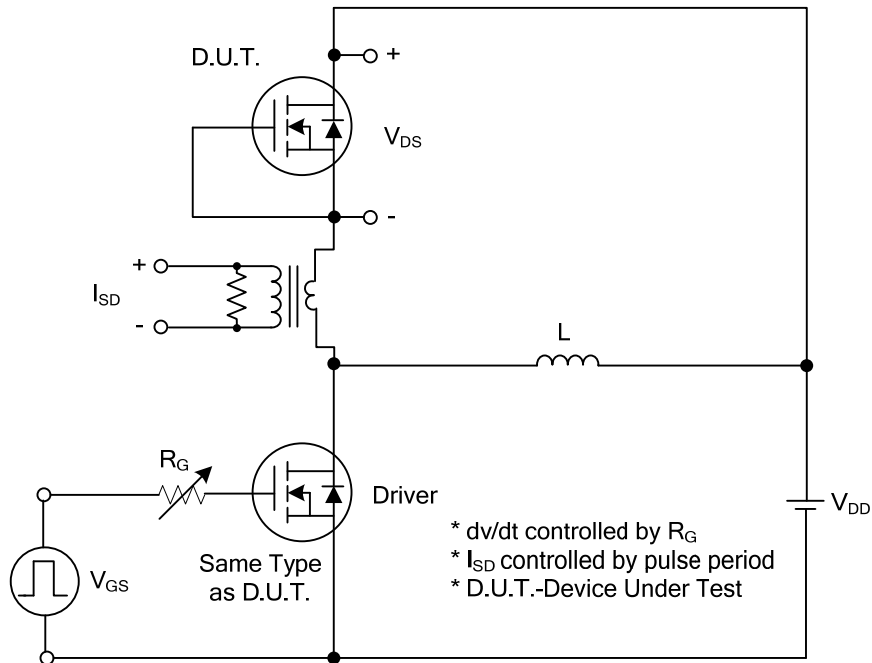

Peak Diode Recovery dv/dt Test Circuit

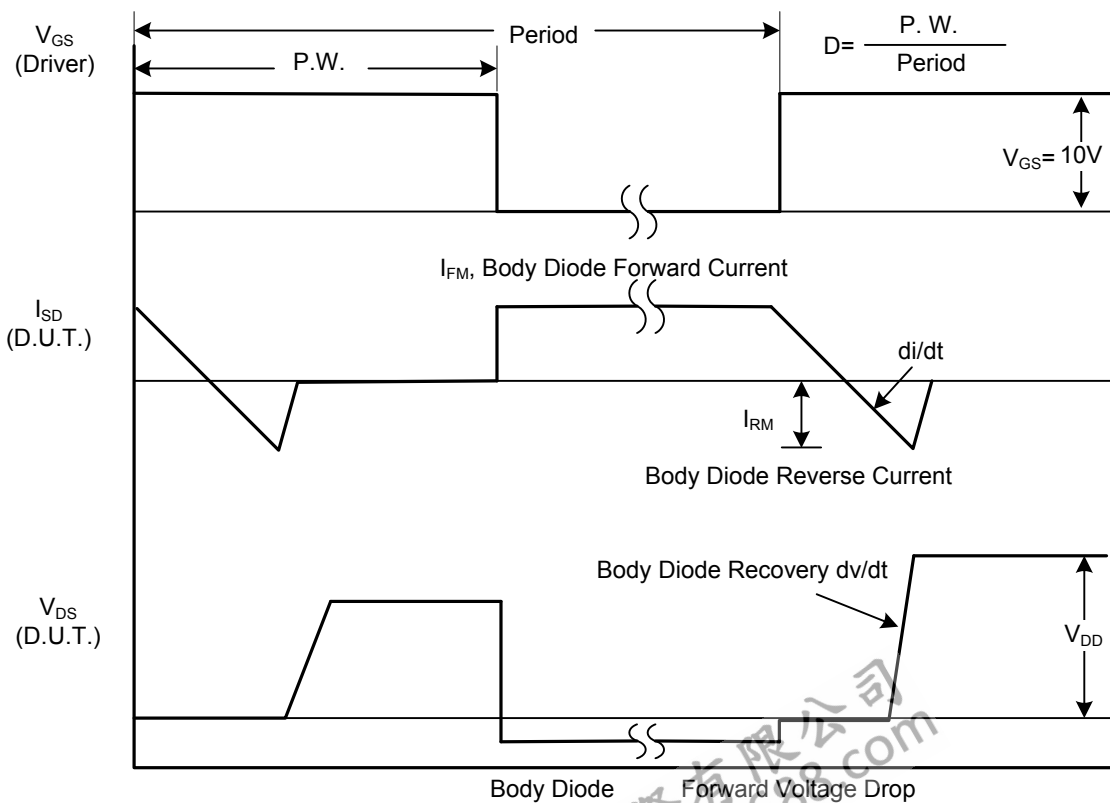

Peak Diode Recovery dv/dt Waveforms

■ TEST CIRCUITS AND WAVEFORMS (Cont.)

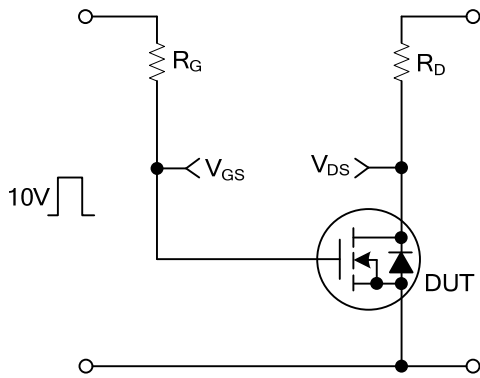

Switching Test Circuit

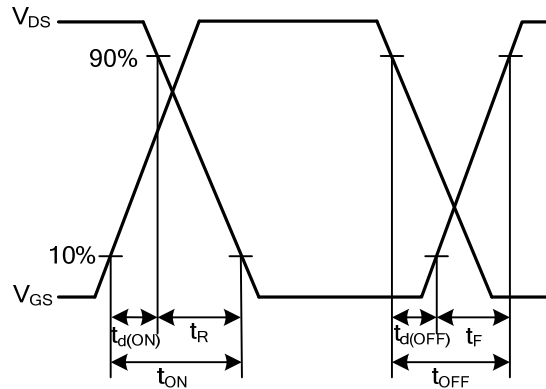

Switching Waveforms

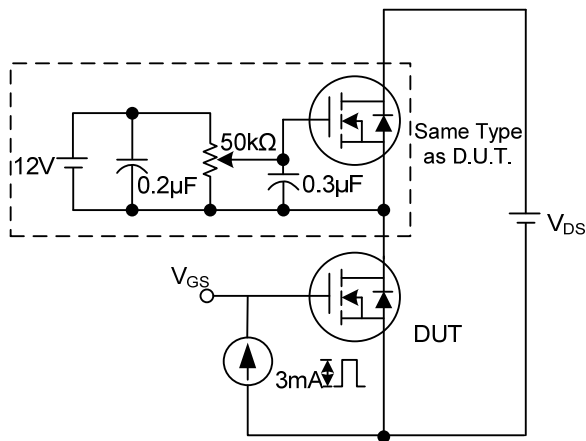

Gate Charge Test Circuit

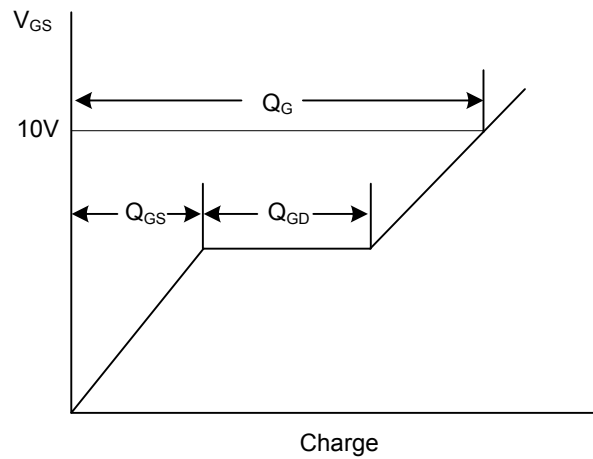

Gate Charge Waveform

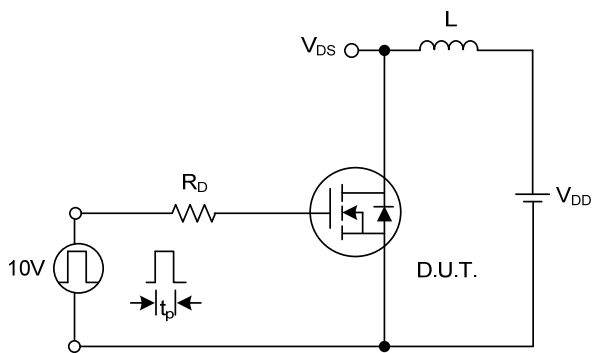

Unclamped Inductive Switching Test Circuit

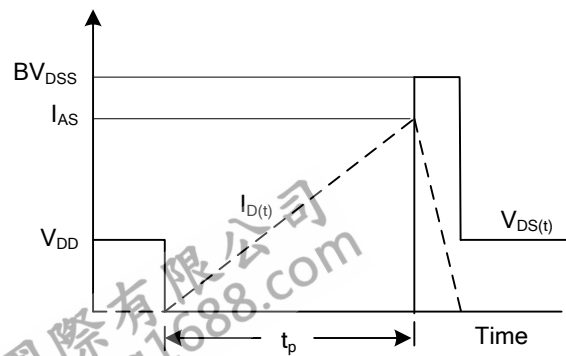

Unclamped Inductive Switching Waveforms

UTC assumes no responsibility for equipment failures that result from using products at values that exceed, even momentarily, rated values (such as maximum ratings, operating condition ranges, or other parameters) listed in products specifications of any and all UTC products described or contained herein. UTC products are not designed for use in life support appliances, devices or systems where malfunction of these products can be reasonably expected to result in personal injury. Reproduction in whole or in part is prohibited without the prior written consent of the copyright owner. The information presented in this document does not form part of any quotation or contract, is believed to be accurate and reliable and may be changed without notice.