



1P50

Preliminary

POWER MOSFET

**-1A, -500V P-CHANNEL
POWER MOSFET**

■ DESCRIPTION

The UTC **1P50** is a P-channel MOS Field Effect Transistor. it uses UTC's advanced technology to provide the customers with high switching speed and a minimum on-state resistance.

The UTC **1P50** is suitable for high voltage switching applications.

■ FEATURES

- * $R_{DS(ON)} < 14\Omega$ @ $V_{GS} = -10V, I_D = -0.5A$
- * High switching speed
- * Low input capacitance

■ SYMBOL

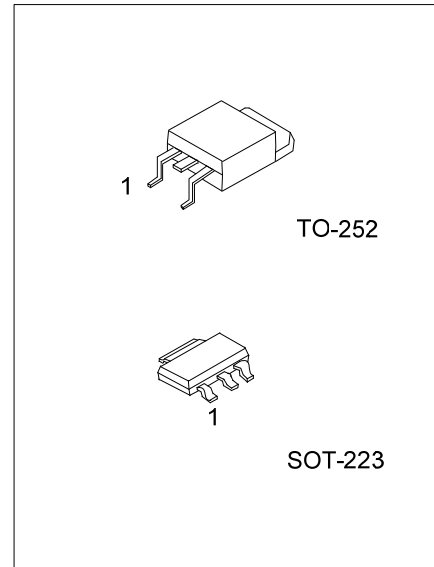
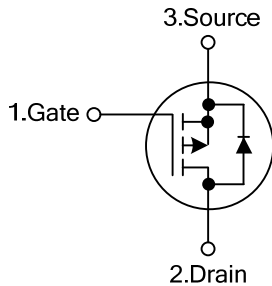

■ ORDERING INFORMATION

Ordering Number		Package	Pin Assignment			Packing
Lead Free	Halogen Free		1	2	3	
1P50L-AA3-R	1P50G-AA3-R	SOT-223	G	D	S	Tape Reel
1P50L-TN3-R	1P50G-TN3-R	TO-252	G	D	S	Tape Reel

Note: Pin Assignment: G: Gate D: Drain S: Source

<p>1P50G-AA3-R</p> <ul style="list-style-type: none"> (1) Packing Type (2) Package Type (3) Green Package 	<ul style="list-style-type: none"> (1) R: Tape Reel (2) AA3: SOT-223, TN3: TO-252 (3) G: Halogen Free and Lead Free, L: Lead Free
--	--

■ MARKING

SOT-223	TO-252

■ ABSOLUTE MAXIMUM RATING ($T_A=25^\circ\text{C}$ unless otherwise specified)

PARAMETER		SYMBOL	RATINGS	UNIT
Drain-Source Voltage		V_{DSS}	-500	V
Gate-Source Voltage		V_{GSS}	± 30	V
Drain Current	DC	I_D	-1	A
	Pulsed (Note 2)	I_{DM}	-2	A
Single Avalanche Energy (Note 3)		E_{AS}	53	mJ
Peak Diode Recovery dv/dt (Note 4)		dv/dt	5	V/ns
Power Dissipation ($T_C=25^\circ\text{C}$)	SOT-223	P_D	7.8	W
	TO-252		50	W
Junction Temperature		T_J	+150	$^\circ\text{C}$
Storage Temperature Range		T_{STG}	-55 ~ +150	$^\circ\text{C}$

Notes: 1. Absolute maximum ratings are those values beyond which the device could be permanently damaged.

Absolute maximum ratings are stress ratings only and functional device operation is not implied.

2. Repetitive Rating : Pulse width limited by maximum junction temperature.

3. $L=88\text{mH}$, $I_{AS}=-1.1\text{A}$, $V_{DD}=-50\text{V}$, $R_G=25\Omega$, Starting $T_J=25^\circ\text{C}$.

4. $I_{SD}\leq-1.0\text{A}$, $di/dt\leq 200\text{A}/\mu\text{s}$, $V_{DD}\leq BV_{DSS}$, Starting $T_J=25^\circ\text{C}$.

■ THERMAL DATA

PARAMETER		SYMBOL	RATINGS	UNIT
Junction to Ambient	SOT-223	θ_{JA}	150	$^\circ\text{C}/\text{W}$
	TO-252		110	$^\circ\text{C}/\text{W}$
Junction to Case	SOT-223	θ_{JC}	16	$^\circ\text{C}/\text{W}$
	TO-252		2.5	$^\circ\text{C}/\text{W}$

■ ELECTRICAL CHARACTERISTICS (T_A=25°C unless otherwise specified)

PARAMETER	SYMBOL	TEST CONDITIONS	MIN	TYP	MAX	UNIT
OFF CHARACTERISTICS						
Drain-Source Leakage Current	I _{DSS}	V _{DS} =-500V, V _{GS} =0V			-1.0	μA
Gate-Source Leakage Current	I _{GSS}	V _{GS} =+30V, V _{DS} =0V			+100	nA
		V _{GS} =-30V, V _{DS} =0V			-100	nA
ON CHARACTERISTICS						
Gate Threshold Voltage	V _{GS(TH)}	V _{DS} = V _{GS} , I _D =-250μA	-2.0		-4.0	V
Static Drain-Source On-State Resistance	R _{DS(ON)}	V _{GS} =-10V, I _D =-0.5A			14	Ω
DYNAMIC PARAMETERS						
Input Capacitance	C _{ISS}	V _{GS} =0V, V _{DS} =-25V, f=1.0MHz		165		pF
Output Capacitance	C _{OSS}			34		pF
Reverse Transfer Capacitance	C _{RSS}			5.2		pF
SWITCHING PARAMETERS						
Total Gate Charge	Q _G	V _{DS} =-50V, V _{GS} =-10V, I _D =-1.3A , I _G =-100μA (Note 1, 2)		15		nC
Gate to Source Charge	Q _{GS}			2		nC
Gate to Drain Charge	Q _{GD}			3		nC
Turn-ON Delay Time	t _{D(ON)}	V _{DD} =-50V, V _{GS} =-10V, I _D =-0.5A, R _G =-25Ω (Note 1, 2)		30		ns
Rise Time	t _R			25		ns
Turn-OFF Delay Time	t _{D(OFF)}			70		ns
Fall-Time	t _F			24		ns
SOURCE-DRAIN DIODE RATINGS AND CHARACTERISTICS						
Maximum Body-Diode Continuous Current	I _S				-1	A
Maximum Body-Diode Pulsed Current	I _{SM}				-2	A
Diode Forward Voltage	V _{SD}	I _F =-1.0A, V _{GS} =0V			-1.4	V
Body Diode Reverse Recovery Time	t _{rr}	I _F =-1.0A, V _{GS} =0V, di/dt=100A/μs		150		ns
Body Diode Reverse Recovery Charge	Q _{rr}			0.85		nC

Notes: 1. Pulse Test: Pulse width ≤ 300μs, Duty cycle ≤ 2%.

2. Essentially independent of operating temperature.

■ TEST CIRCUITS AND WAVEFORMS

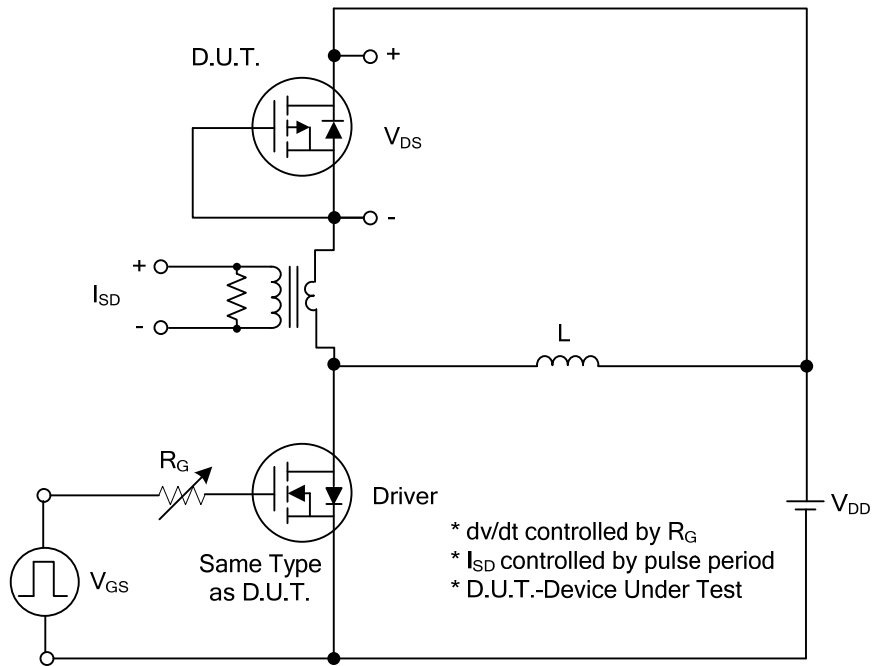

Peak Diode Recovery dv/dt Test Circuit

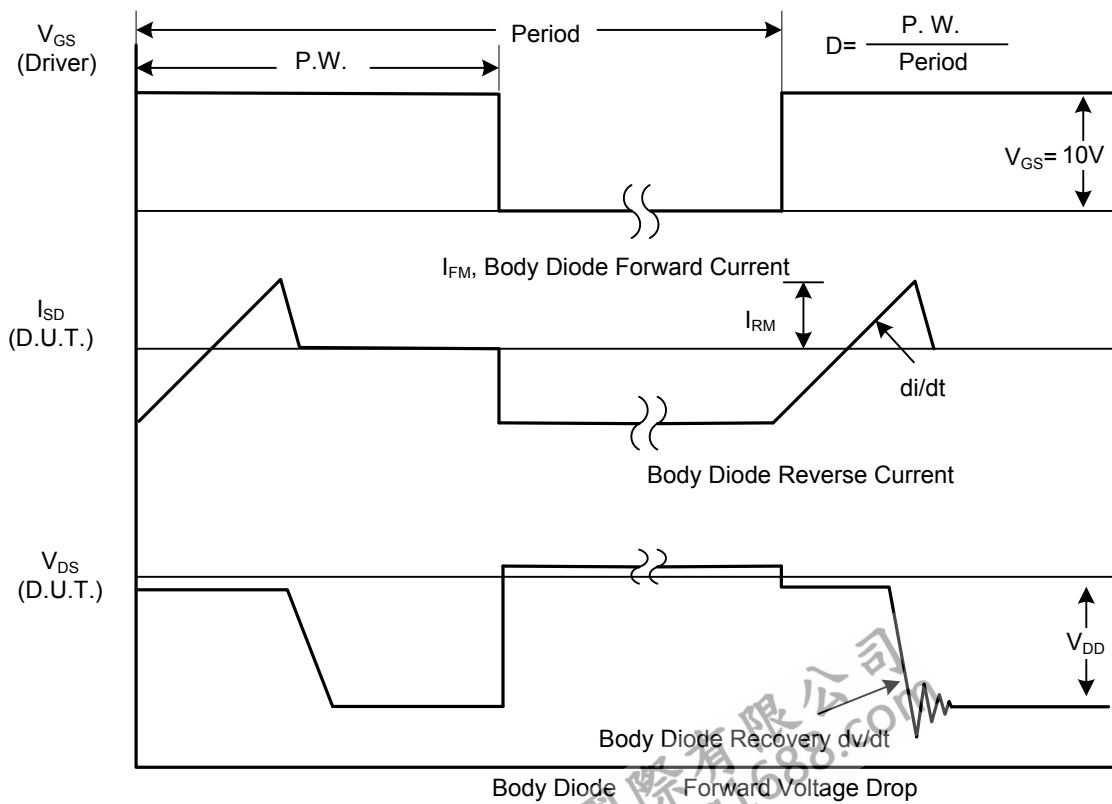

Peak Diode Recovery dv/dt Waveforms

■ TEST CIRCUITS AND WAVEFORMS

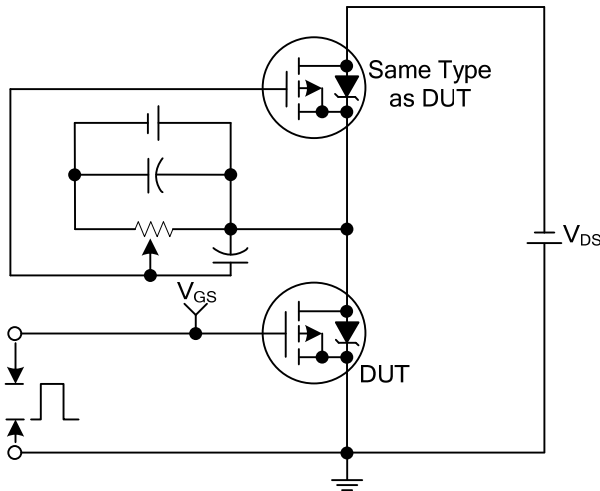

Gate Charge Test Circuit

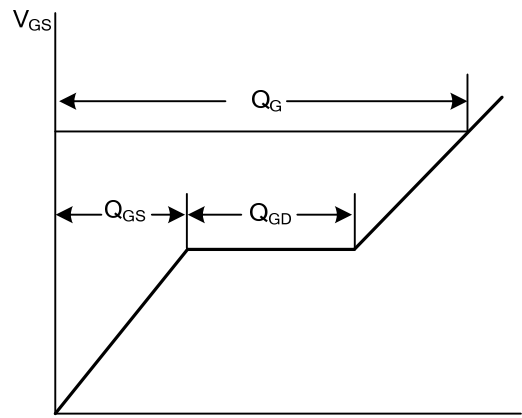

Gate Charge Waveforms

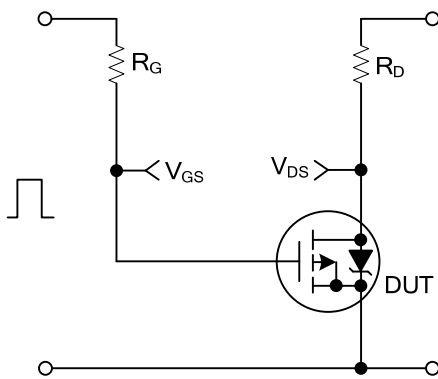

Resistive Switching Test Circuit

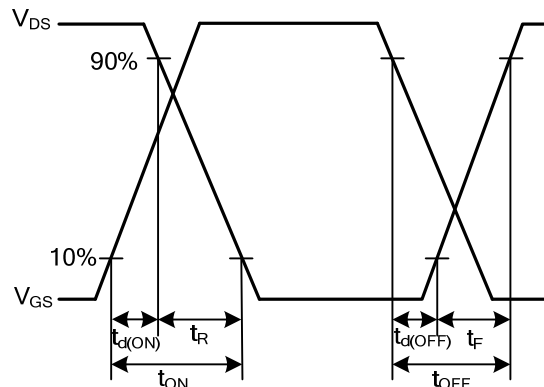

Resistive Switching Waveforms

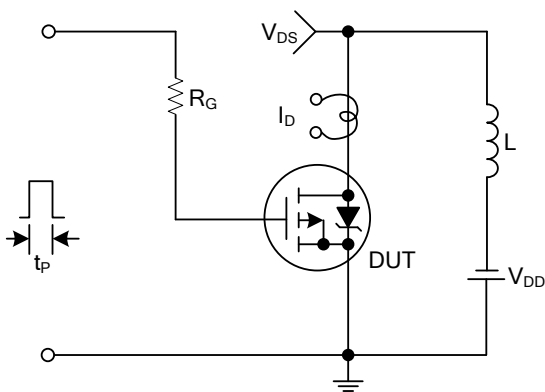

Unclamped Inductive Switching Test Circuit

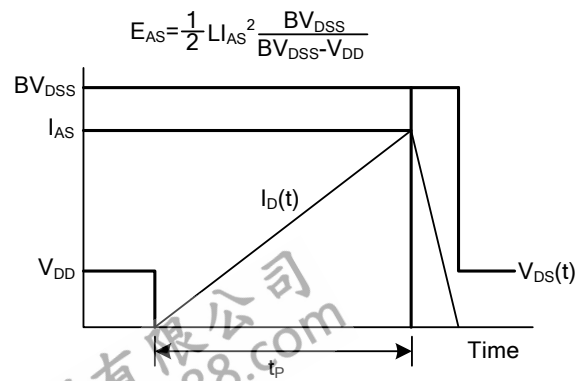

Unclamped Inductive Switching Waveforms

UTC assumes no responsibility for equipment failures that result from using products at values that exceed, even momentarily, rated values (such as maximum ratings, operating condition ranges, or other parameters) listed in products specifications of any and all UTC products described or contained herein. UTC products are not designed for use in life support appliances, devices or systems where malfunction of these products can be reasonably expected to result in personal injury. Reproduction in whole or in part is prohibited without the prior written consent of the copyright owner. UTC reserves the right to make changes to information published in this document, including without limitation specifications and product descriptions, at any time and without notice. This document supersedes and replaces all information supplied prior to the publication hereof.