



## 2N150

Power MOSFET

### 2A, 1500V N-CHANNEL POWER MOSFET

#### DESCRIPTION

The UTC 2N150 provide excellent  $R_{DS(ON)}$ , low gate charge and operation with low gate voltages. This device is suitable for use as a load switch or in PWM applications.

#### FEATURES

- \*  $R_{DS(ON)} \leq 13\Omega$  @  $V_{GS}=10V, I_D=1.0A$
- \* Low Reverse Transfer Capacitance
- \* Fast Switching Capability
- \* Avalanche Energy Specified
- \* Improved dv/dt Capability, High Ruggedness

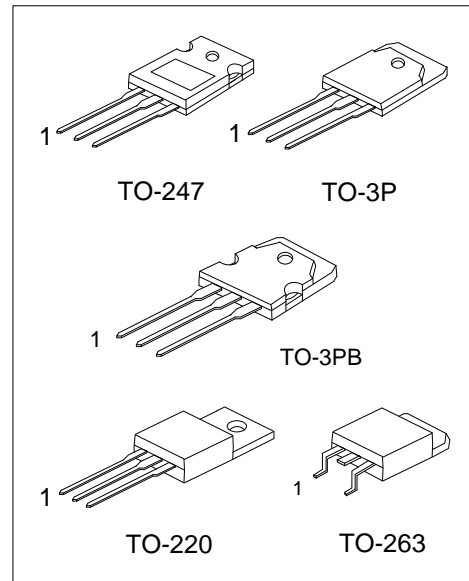

#### SYMBOL

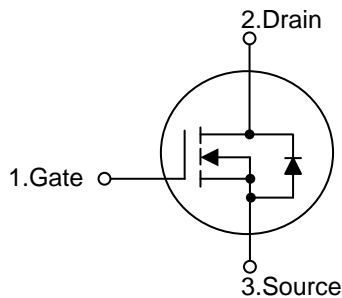

#### ORDERING INFORMATION

Ordering Number		Package	Pin Assignment			Packing
Lead Free	Halogen Free		1	2	3	
2N150L-TA3-T	2N150G-TA3-T	TO-220	G	D	S	Tube
2N150L-TQ2-T	2N150G-TQ2-T	TO-263	G	D	S	Tube
2N150L-TQ2-R	2N150G-TQ2-R	TO-263	G	D	S	Tape Reel
2N150L-T3P-T	2N150G-T3P-T	TO-3P	G	D	S	Tube
2N150L-T3B-T	2N150G-T3B-T	TO-3PB	G	D	S	Tube
2N150L-T47-T	2N150G-T47-T	TO-247	G	D	S	Tube

Note: Pin Assignment: G: Gate D: Drain S: Source

<p>2N150G-TA3-T</p> <p>(1)Packing Type</p> <p>(2)Package Type</p> <p>(3)Green Package</p>	<p>(1) T: Tube, R: Tape Reel</p> <p>(2) TA3: TO-220, TQ2: TO-263, T3P: TO-3P, T3B: TO-3PB, T47: TO-247</p> <p>(3) G: Halogen Free and Lead Free, L: Lead Free</p>
---	---

MARKING

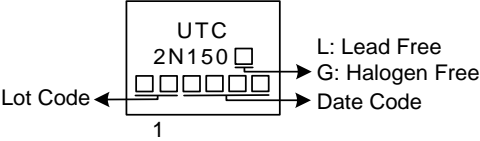

FLYING 汎翔國際有限公司  
www.flying1688.com

■ **ABSOLUTE MAXIMUM RATINGS** ( $T_C=25^{\circ}\text{C}$ , unless otherwise specified)

PARAMETER		SYMBOL	RATINGS	UNIT
Drain-Source Voltage		$V_{DSS}$	1500	V
Gate-Source Voltage		$V_{GSS}$	$\pm 30$	V
Drain Current	Continuous	$I_D$	2	A
	Pulsed (Note 2)	$I_{DM}$	4	A
Avalanche Energy	Single Pulsed (Note 3)	$E_{AS}$	198	mJ
Peak Diode Recovery dv/dt (Note 4)		dv/dt	1.96	V/ns
Power Dissipation	TO-220/TO-263	$P_D$	100	W
	TO-247/TO-3P		140	W
	TO-3PB			
Junction Temperature		$T_J$	+150	$^{\circ}\text{C}$
Storage Temperature		$T_{STG}$	-55 ~ +150	$^{\circ}\text{C}$

Notes: 1. Absolute maximum ratings are those values beyond which the device could be permanently damaged.

Absolute maximum ratings are stress ratings only and functional device operation is not implied.

2. Repetitive Rating : Pulse width limited by maximum junction temperature.

3.  $L=155\text{mH}$ ,  $I_{AS}=2.4\text{A}$ ,  $V_{DD}=90\text{V}$ ,  $R_G=25\ \Omega$ , Starting  $T_J = 25^{\circ}\text{C}$

4.  $I_{SD}\leq 2.0\text{A}$ ,  $di/dt\leq 200\text{A}/\mu\text{s}$ ,  $V_{DD}\leq BV_{DSS}$ , Starting  $T_J = 25^{\circ}\text{C}$

■ **THERMAL DATA**

PARAMETER		SYMBOL	RATING	UNIT
Junction to Ambient	TO-220/TO-263	$\theta_{JA}$	62.5	$^{\circ}\text{C}/\text{W}$
	TO-247/TO-3P		50	$^{\circ}\text{C}/\text{W}$
	TO-3PB			
Junction to Case	TO-220/TO-263	$\theta_{JC}$	1.25	$^{\circ}\text{C}/\text{W}$
	TO-247/TO-3P		0.89	$^{\circ}\text{C}/\text{W}$
	TO-3PB			

■ **ELECTRICAL CHARACTERISTICS** ( $T_J = 25^\circ\text{C}$ , unless otherwise specified)

PARAMETER	SYMBOL	TEST CONDITIONS	MIN	TYP	MAX	UNIT
<b>OFF CHARACTERISTICS</b>						
Drain-Source Breakdown Voltage	$BV_{DSS}$	$V_{GS}=0V, I_D=250\mu A$	1500			V
Drain-Source Leakage Current	$I_{DSS}$	$V_{DS}=1500V, V_{GS}=0V$			10	$\mu A$
Gate-Source Leakage Current	$I_{GSS}$	$V_{GS}=\pm 30V, V_{DS}=0V$			$\pm 100$	nA
<b>ON CHARACTERISTICS</b>						
Gate Threshold Voltage	$V_{GS(TH)}$	$V_{DS}=V_{GS}, I_D=250\mu A$	3.0		5.0	V
Static Drain-Source On-State Resistance	$R_{DS(ON)}$	$V_{GS}=10V, I_D=1.0A$			13	$\Omega$
<b>DYNAMIC CHARACTERISTICS</b>						
Input Capacitance	$C_{ISS}$	$V_{DS}=25V, V_{GS}=0V, f=1\text{MHz}$		740		pF
Output Capacitance	$C_{OSS}$			55		pF
Reverse Transfer Capacitance	$C_{RSS}$			9.8		pF
<b>SWITCHING CHARACTERISTICS</b>						
Total Gate Charge (Note 1)	$Q_G$	$V_{DS}=1200V, V_{GS}=10V, I_D=2A$ $I_G=1\text{mA}$ (Note 1, 2)		23.5		nC
Gate-Source Charge	$Q_{GS}$			8		nC
Gate-Drain Charge	$Q_{GD}$			8.4		nC
Turn-On Delay Time (Note 1)	$t_{D(ON)}$	$V_{DD}=100V, V_{GS}=10V, I_D=2A,$ $R_G=25\Omega$ (Note 1, 2)		25		ns
Turn-On Rise Time	$t_R$			27		ns
Turn-Off Delay Time	$t_{D(OFF)}$			65		ns
Turn-Off Fall Time	$t_F$			52		ns
<b>SOURCE- DRAIN DIODE RATINGS AND CHARACTERISTICS</b>						
Maximum Continuous Drain-Source Diode Forward Current	$I_S$				2	A
Maximum Pulsed Drain-Source Diode Forward Current	$I_{SM}$				4	A
Drain-Source Diode Forward Voltage (Note 1)	$V_{SD}$	$I_S=2.0A, V_{GS}=0V$			1.4	V
Body Diode Reverse Recovery Time (Note 1)	$t_{rr}$	$I_S=2.0A, V_{GS}=0V,$ $dI_F/dt=100A/\mu s$		688		ns
Body Diode Reverse Recovery Charge	$Q_{rr}$			5.8		$\mu C$

Notes: 1. Pulse Test: Pulse width  $\leq 300\mu s$ , Duty cycle  $\leq 2\%$ .

2. Essentially independent of operating temperature.

■ TEST CIRCUITS AND WAVEFORMS

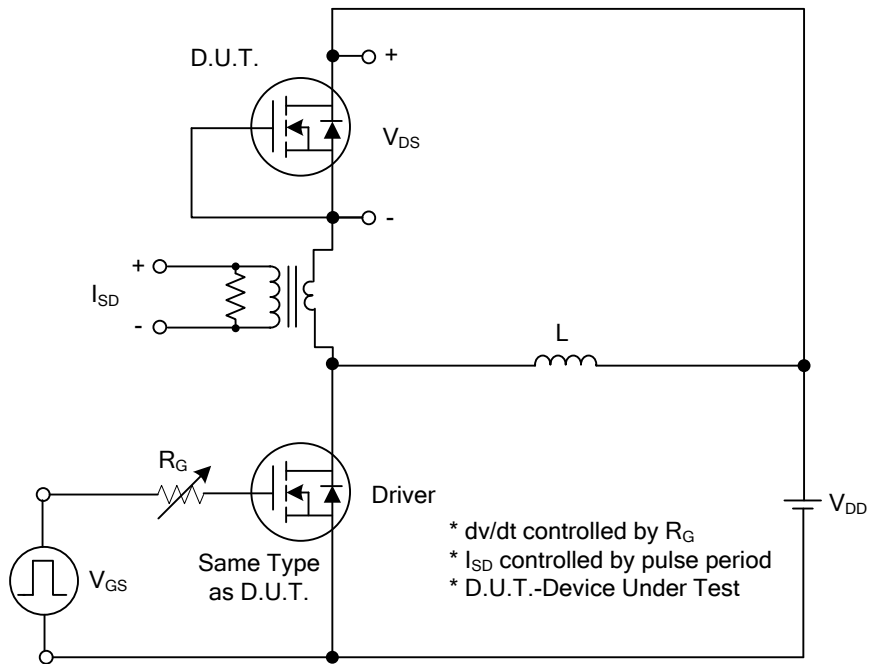

Peak Diode Recovery  $dv/dt$  Test Circuit

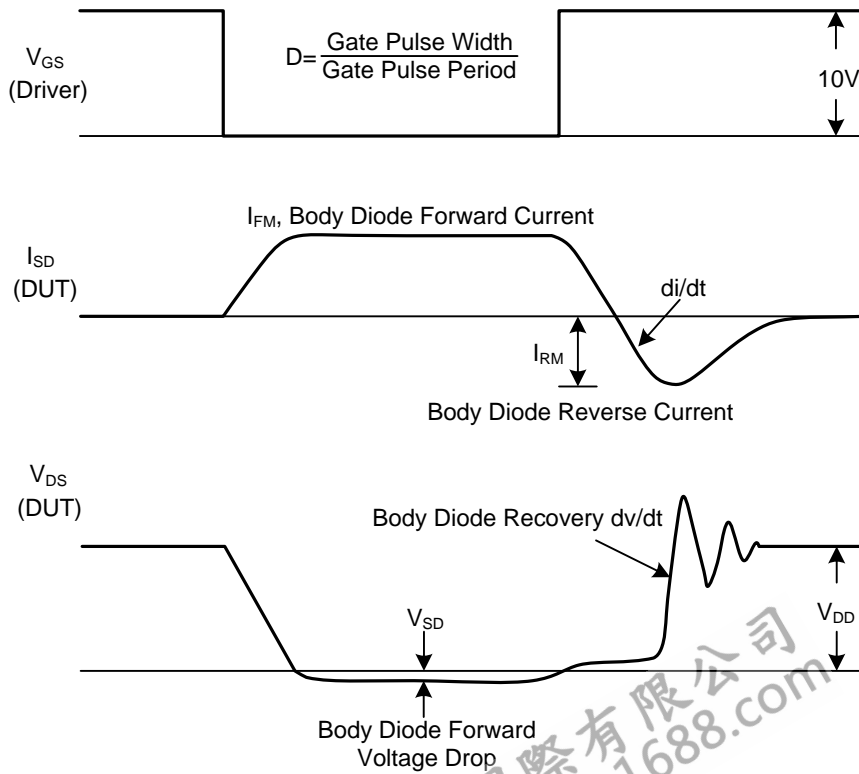

Peak Diode Recovery  $dv/dt$  Waveforms

## TEST CIRCUITS AND WAVEFORMS

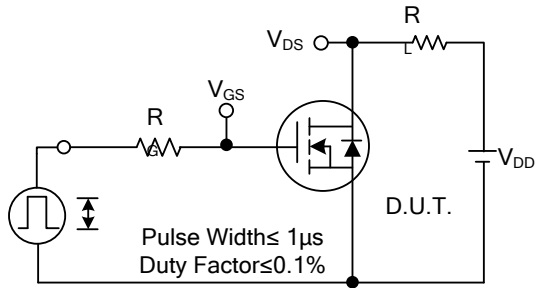

Switching Test Circuit

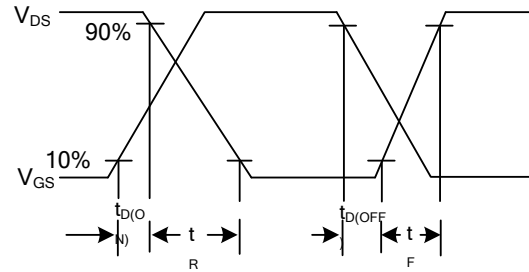

Switching Waveforms

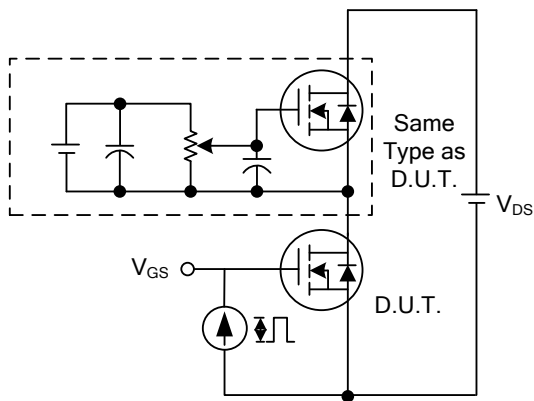

Gate Charge Test Circuit

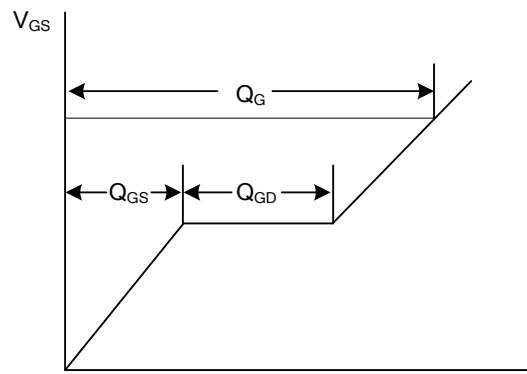

Charge

Gate Charge Waveform

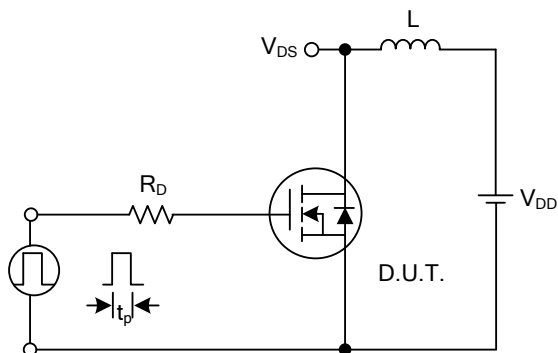

Unclamped Inductive Switching Test Circuit

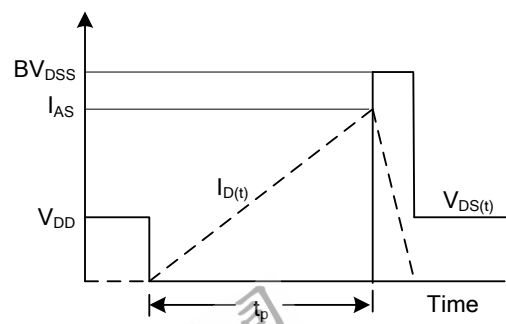

Unclamped Inductive Switching Waveforms

## ■ TYPICAL CHARACTERISTICS

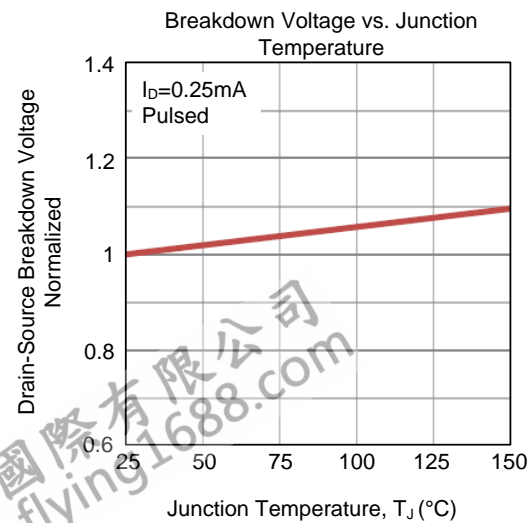
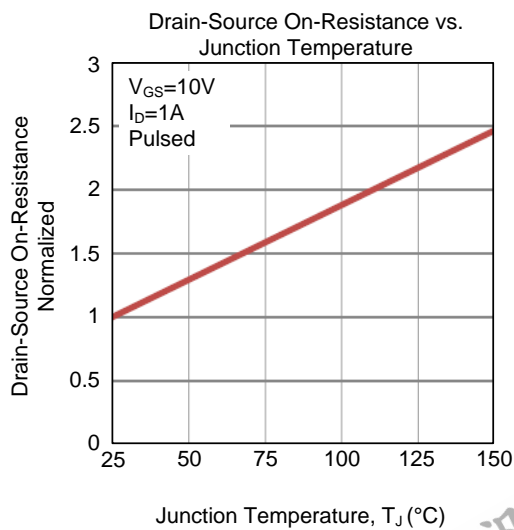
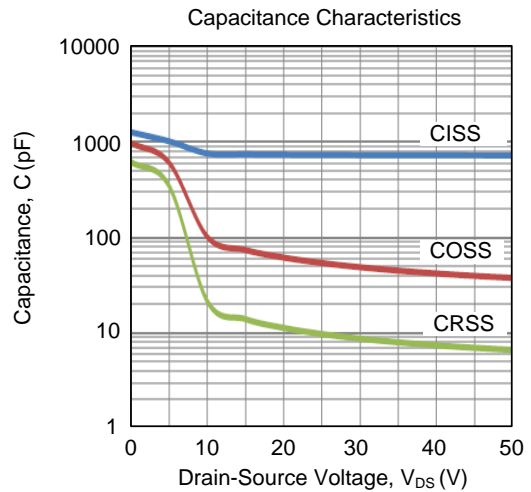
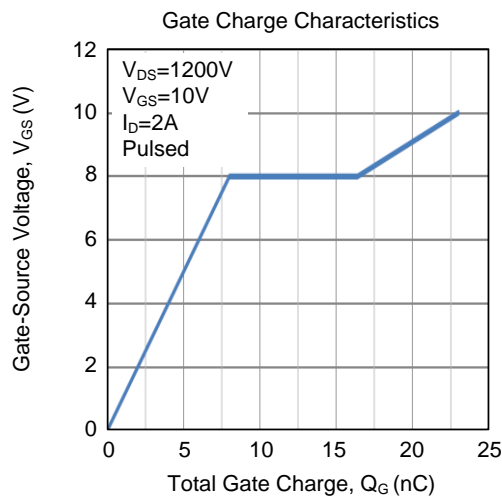
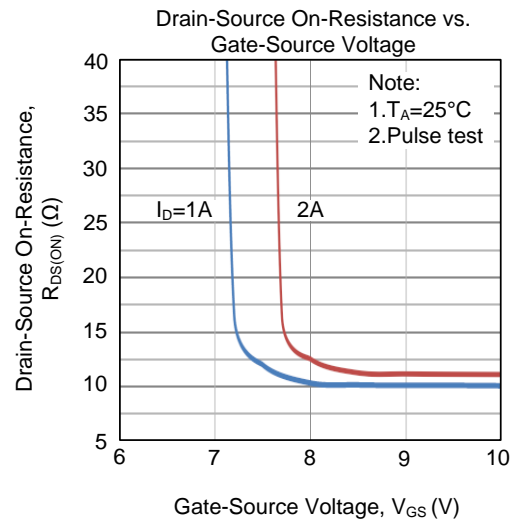
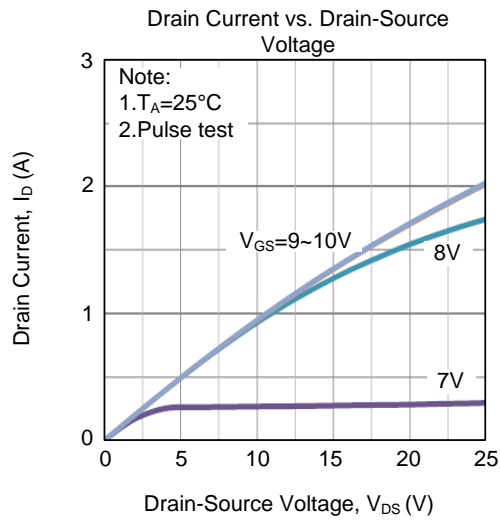

## ■ TYPICAL CHARACTERISTICS (Cont.)

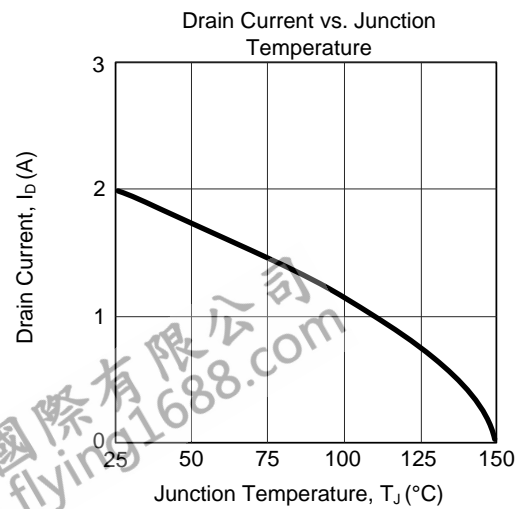
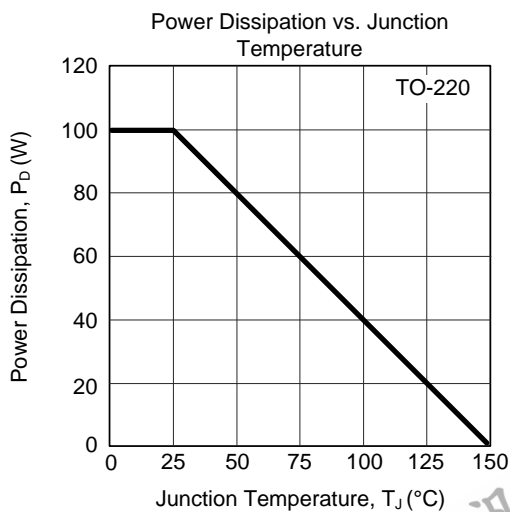
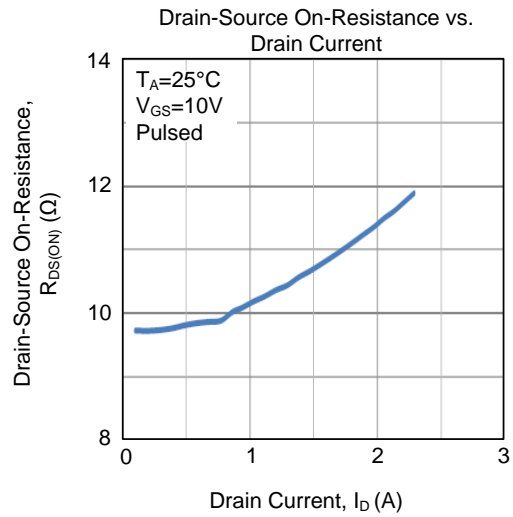
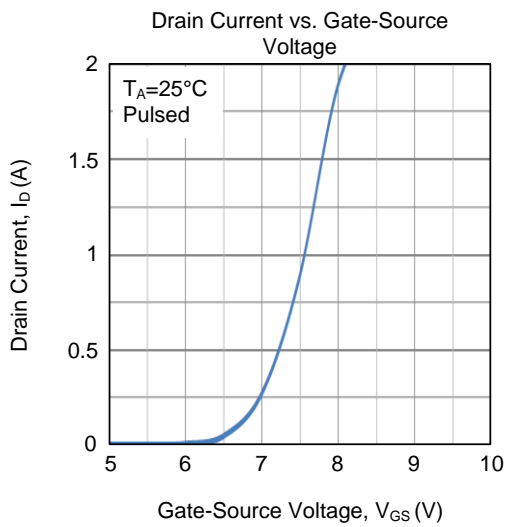
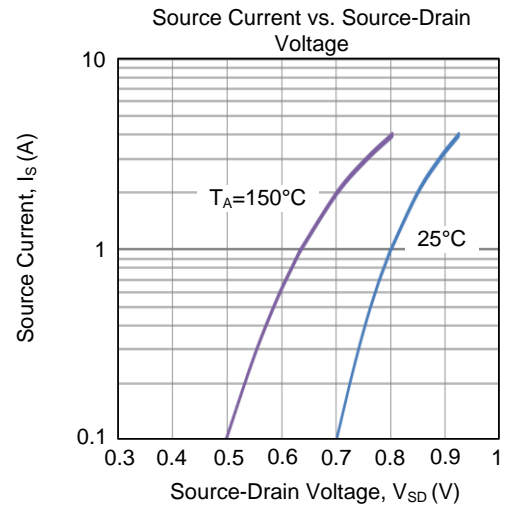
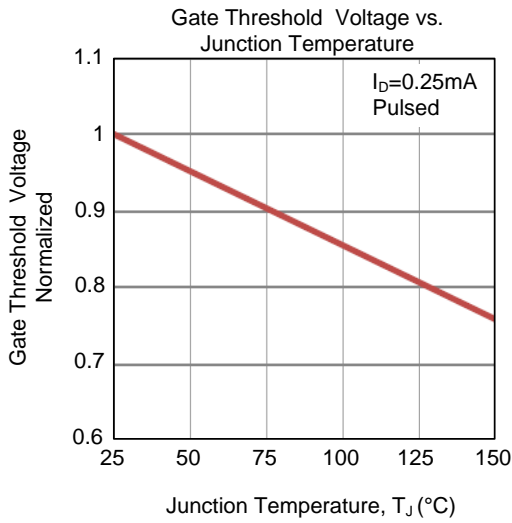



■ TYPICAL CHARACTERISTICS (Cont.)

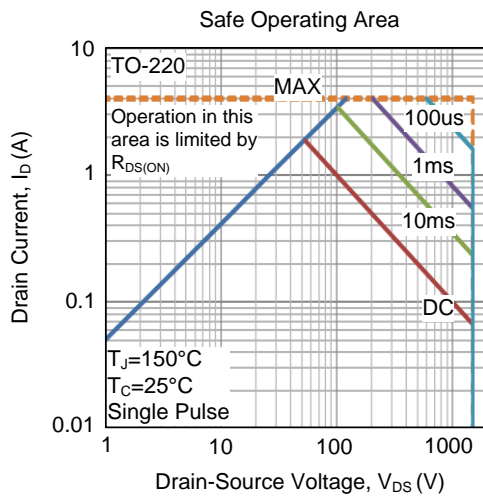

UTC assumes no responsibility for equipment failures that result from using products at values that exceed, even momentarily, rated values (such as maximum ratings, operating condition ranges, or other parameters) listed in products specifications of any and all UTC products described or contained herein. UTC products are not designed for use in life support appliances, devices or systems where malfunction of these products can be reasonably expected to result in personal injury. Reproduction in whole or in part is prohibited without the prior written consent of the copyright owner. UTC reserves the right to make changes to information published in this document, including without limitation specifications and product descriptions, at any time and without notice. This document supersedes and replaces all information supplied prior to the publication hereof.