



2N4403

PNP SILICON TRANSISTOR

PNP GENERAL PURPOSE AMPLIFIER

DESCRIPTION

The UTC **2N4403** is designed for use as a general purpose amplifier and switch requiring collector currents up to 500mA.

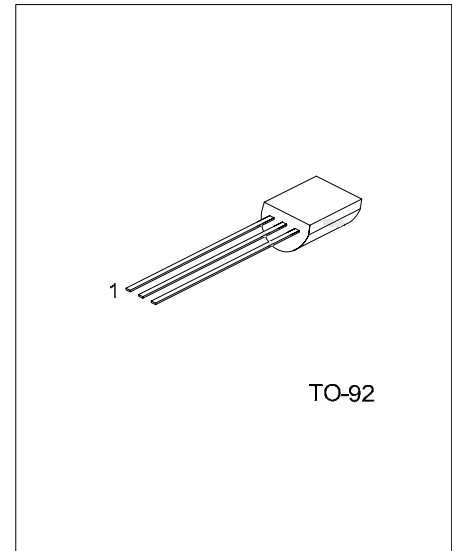

*Pb-free plating product number: 2N4403L

ORDERING INFORMATION

Ordering Number		Package	Pin Assignment			Packing
Normal	Lead Free Plating		1	2	3	
2N4403-T92-B	2N4403L-T92-B	TO-92	E	B	C	Tape Box
2N4403-T92-K	2N4403L-T92-K	TO-92	E	B	C	Bulk

<p>2N4403L-T92-B</p> <p>(1)Packing Type (2)Package Type (3)Lead Plating</p>	<p>(1) B: Tape Box, K: Bulk (2) T92: TO-92 (3) L: Lead Free Plating, Blank: Pb/Sn</p>
---	---



■ ABSOLUTE MAXIMUM RATINGS (Ta=25 , unless otherwise specified)

PARAMETER	SYMBOL	RATINGS	UNIT
Collector-Base Voltage	V_{CBO}	-40	V
Collector-Emitter Voltage	V_{CEO}	-40	V
Emitter-Base Voltage	V_{EBO}	-5	V
Collector Current-Continuous	I_C	-600	mA
Total Device Dissipation	P_C	625	mW
Derate above 25		5.0	mW/
Junction Temperature	T_J	+150	
Storage Temperature	T_{STG}	-55 ~ +150	

Note 1. Absolute maximum ratings are those values beyond which the device could be permanently damaged.

Absolute maximum ratings are stress ratings only and functional device operation is not implied.

2. These are steady state limits. The factory should be consulted on applications involving pulsed or low duty cycle operations.

■ THERMAL DATA (Ta=25 , unless otherwise specified)

CHARACTERISTIC	SYMBOL	RATINGS	UNIT
Thermal Resistance, Junction to Ambient	θ_{JA}	200	/W
Thermal Resistance, Junction to Case	θ_{JC}	83.3	/W

■ ELECTRICAL CHARACTERISTICS (Ta=25 , unless otherwise specified)

PARAMETER	SYMBOL	TEST CONDITIONS	MIN	TYP	MAX	UNIT
OFF CHARACTERISTICS						
Collector-Emitter Breakdown Voltage (Note)	BV_{CEO}	$I_C=-1mA, I_B=0$	-40			V
Collector-Base Breakdown Voltage	BV_{CBO}	$I_C=-0.1mA, I_E=0$	-40			V
Emitter-Base Breakdown Voltage	BV_{EBO}	$I_E=-0.1mA, I_C=0$	-5			V
Collector Cut-off Current	I_{CEX}	$V_{CE}=-35V, V_{EB}=-0.4V$			-0.1	μA
Base Cut-off Current	I_{BEX}	$V_{CE}=-35V, V_{BE}=-0.4V$			-0.1	μA
ON CHARACTERISTICS*						
DC Current Gain	h_{FE1}	$V_{CE}=-1V, I_C=-0.1mA$	30			
	h_{FE2}	$V_{CE}=-1V, I_C=-1mA$	60			
	h_{FE3}	$V_{CE}=-1V, I_C=-10mA$	100			
	h_{FE4}	$V_{CE}=-2V, I_C=-150mA$ (Note)	100		300	
	h_{FE5}	$V_{CE}=-2V, I_C=-500mA$ (Note)	20			
Collector-Emitter Saturation Voltage	$V_{CE(SAT1)}$	$I_C=-150mA, I_B=-15mA$			-0.4	V
	$V_{CE(SAT2)}$	$I_C=-500mA, I_B=-50mA$			-0.75	V
Base-Emitter Saturation Voltage	$V_{BE(SAT1)}$	$I_C=-150mA, I_B=-15mA$ (Note)	-0.75		-0.95	V
	$V_{BE(SAT2)}$	$I_C=-500mA, I_B=-50mA$			-1.3	V
SMALL SIGNAL CHARACTERISTICS						
Transition Frequency	f_T	$V_{CE}=-10V, I_C=-20mA, f=100MHz$	200			MHz
Collector-Base Capacitance	C_{cb}	$V_{CB}=-10V, I_E=0, f=140kHz$			8.5	pF
Emitter-Base Capacitance	C_{eb}	$V_{BE}=-0.5V, I_C=0, f=140kHz$			30	pF
Input Impedance	h_{iE}	$V_{CE}=-10V, I_C=-1mA, f=1kHz$	1.5		15	k Ω
Voltage Feedback Ratio	h_{rE}	$V_{CE}=-10V, I_C=-1mA, f=1kHz$	0.1		8	$\times 10^{-4}$
Small-Signal Current Gain	h_{FE}	$V_{CE}=-10V, I_C=-1mA, f=1kHz$	60		500	
Output Admittance	h_{oE}	$V_{CE}=-10V, I_C=-1mA, f=1kHz$	1.0		100	$\mu mhos$
SWITCHING CHARACTERISTICS						
Delay Time	t_D	$V_{CC}=-30V, I_C=-150mA, I_{B1}=-15mA$			15	ns
Rise Time	t_R				20	ns
Storage Time	t_S	$V_{CC}=-30V, I_C=-150mA, I_{B1}=I_{B2}=-15mA$			225	ns
Fall Time	t_F				30	ns

Note: Pulse test: Pulse Width \leq 300 μs , Duty Cycle \leq 2%

■ TEST CIRCUIT

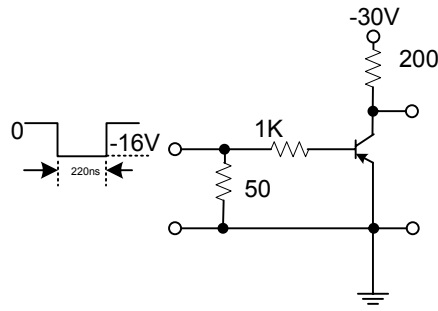

Figure 1. Saturated Turn-On Switching Timer

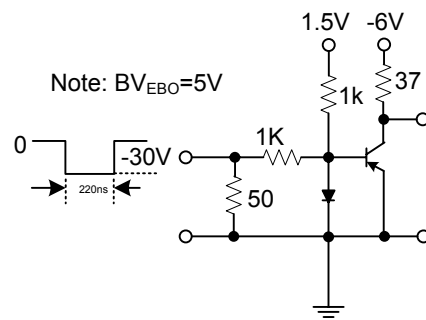
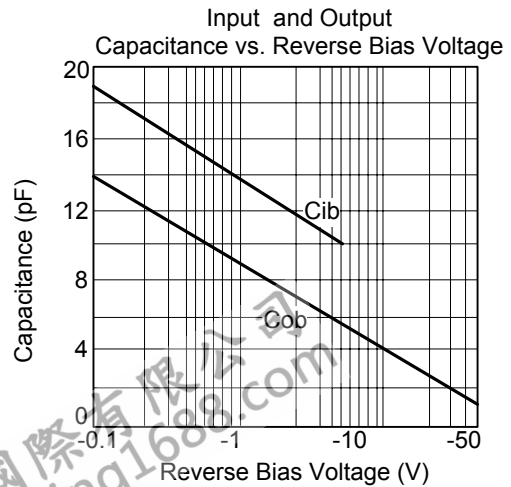
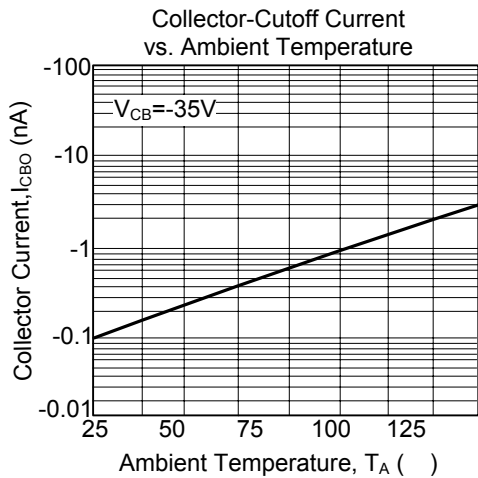
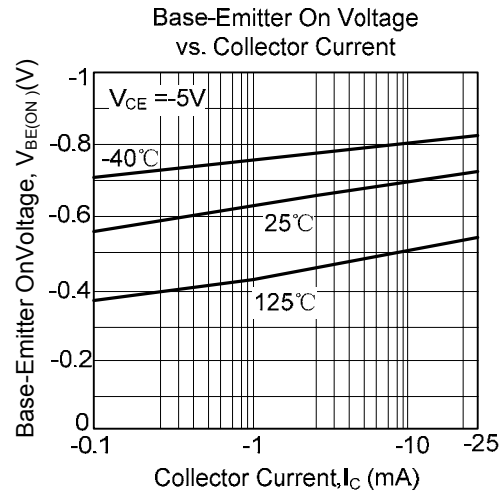
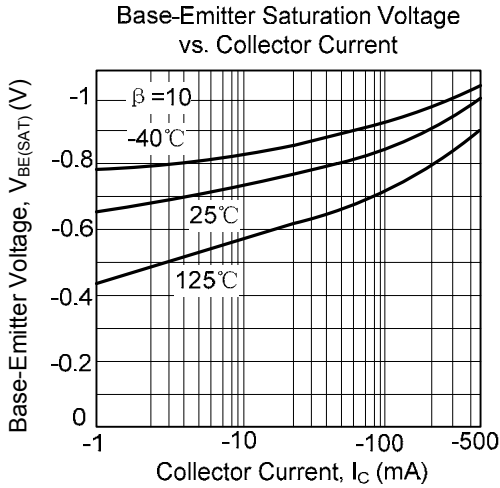
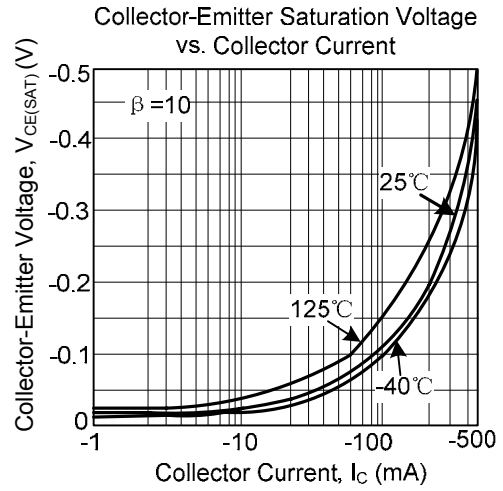
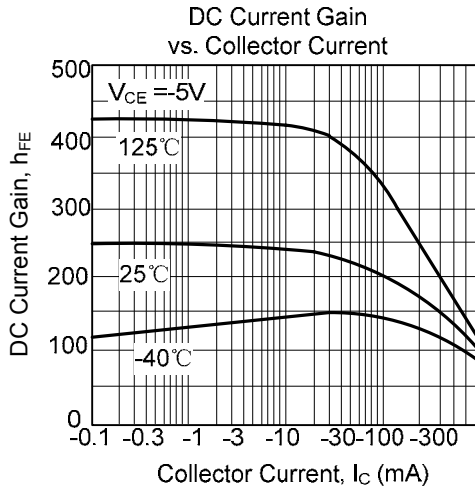

Figure 2. Saturated Turn-Off Switching Timer

TYPICAL CHARACTERISTICS



UTC assumes no responsibility for equipment failures that result from using products at values that exceed, even momentarily, rated values (such as maximum ratings, operating condition ranges, or other parameters) listed in products specifications of any and all UTC products described or contained herein. UTC products are not designed for use in life support appliances, devices or systems where malfunction of these products can be reasonably expected to result in personal injury. Reproduction in whole or in part is prohibited without the prior written consent of the copyright owner. The information presented in this document does not form part of any quotation or contract, is believed to be accurate and reliable and may be changed without notice.