



2N50-LC1

Power MOSFET

2A, 500V N-CHANNEL POWER MOSFET

DESCRIPTION

The UTC **2N50-LC1** is an N-channel power MOSFET using UTC's advanced technology to provide customers with a minimum on-state resistance and superior switching performance.

The UTC **2N50-LC1** is generally applied in low power switching mode power appliances and electronic ballast.

FEATURES

- * $R_{DS(ON)} \leq 4.2\Omega$ @ $V_{GS}=10V, I_D=1.0A$
- * High Switching Speed
- * 100% Avalanche Tested

SYMBOL

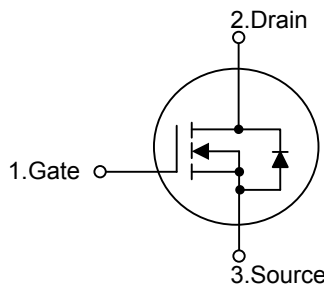

ORDERING INFORMATION

| Ordering Number | | Package | Pin Assignment | | | Packing |
|-----------------|--------------|---------|----------------|---|---|---------|
| Lead Free | Halogen Free | | 1 | 2 | 3 | |
| 2N50L-TM3-T | 2N50G-TM3-T | TO-251 | G | D | S | Tube |

Note: Pin Assignment: G: Gate D: Drain S: Source

| | |
|--|--|
| <p>2N50G-TM3-T</p> <p>(1)Packing Type</p> <p>(2)Package Type</p> <p>(3)Green Package</p> | <p>(1) T: Tube</p> <p>(2) TM3: TO-251</p> <p>(3) G: Halogen Free and Lead Free, L: Lead Free</p> |
|--|--|

MARKING

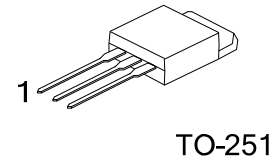
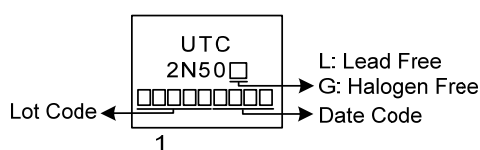

■ ABSOLUTE MAXIMUM RATINGS ($T_c=25^\circ\text{C}$, unless otherwise specified)

| PARAMETER | | SYMBOL | RATINGS | UNIT |
|------------------------------------|------------------------|-----------|------------|------------------|
| Drain-Source Voltage | | V_{DSS} | 500 | V |
| Gate-Source Voltage | | V_{GSS} | ± 30 | V |
| Drain Current | Continuous | I_D | 2 | A |
| | Pulsed (Note 2) | I_{DM} | 4 | A |
| Avalanche Energy | Single Pulsed (Note 3) | E_{AS} | 39.2 | mJ |
| Peak Diode Recovery dv/dt (Note 4) | | dv/dt | 2.28 | V/ns |
| Power Dissipation | | P_D | 45 | W |
| Junction Temperature | | T_J | +150 | $^\circ\text{C}$ |
| Storage Temperature | | T_{STG} | -55 ~ +150 | $^\circ\text{C}$ |

Notes: 1. Absolute maximum ratings are those values beyond which the device could be permanently damaged.

Absolute maximum ratings are stress ratings only and functional device operation is not implied.

2. Repetitive Rating: Pulse width limited by maximum junction temperature.

3. $L = 10\text{mH}$, $I_{AS} = 2.8\text{A}$, $V_{DD} = 50\text{V}$, $R_G = 25\Omega$, Starting $T_J = 25^\circ\text{C}$

4. $I_{SD} \leq 2.0\text{A}$, $di/dt \leq 200\text{A}/\mu\text{s}$, $V_{DD} \leq BV_{DSS}$, Starting $T_J = 25^\circ\text{C}$

■ THERMAL CHARACTERISTICS

| PARAMETER | SYMBOL | RATINGS | UNIT |
|---------------------|---------------|-------------|---------------------------|
| Junction to Ambient | θ_{JA} | 100 | $^\circ\text{C}/\text{W}$ |
| Junction to Case | θ_{JC} | 2.77 (Note) | $^\circ\text{C}/\text{W}$ |

Note: Device mounted on FR-4 substrate PC board, 2oz copper, with 1inch square copper plate.

■ ELECTRICAL CHARACTERISTICS ($T_J=25^\circ\text{C}$, unless otherwise specified)

| PARAMETER | SYMBOL | TEST CONDITIONS | MIN | TYP | MAX | UNIT |
|--|--------------|--|---|------|------|---------------|
| OFF CHARACTERISTICS | | | | | | |
| Drain-Source Breakdown Voltage | BV_{DSS} | $I_D=250\mu\text{A}$, $V_{GS}=0\text{V}$ | 500 | | | V |
| Drain-Source Leakage Current | I_{DSS} | $V_{DS}=500\text{V}$, $V_{GS}=0\text{V}$ | | | 10 | μA |
| Gate- Source Leakage Current | Forward | $V_{GS}=+30\text{V}$, $V_{DS}=0\text{V}$ | | | +100 | nA |
| | Reverse | | $V_{GS}=-30\text{V}$, $V_{DS}=0\text{V}$ | | | -100 |
| ON CHARACTERISTICS | | | | | | |
| Gate Threshold Voltage | $V_{GS(TH)}$ | $V_{DS}=V_{GS}$, $I_D=250\mu\text{A}$ | 2.0 | | 4.0 | V |
| Static Drain-Source On-State Resistance | $R_{DS(ON)}$ | $V_{GS}=10\text{V}$, $I_D=1.0\text{A}$ | | | 4.2 | Ω |
| DYNAMIC PARAMETERS | | | | | | |
| Input Capacitance | C_{ISS} | $V_{GS}=0\text{V}$, $V_{DS}=25\text{V}$, $f=1.0\text{MHz}$ | | 225 | | pF |
| Output Capacitance | C_{OSS} | | | 30 | | pF |
| Reverse Transfer Capacitance | C_{RSS} | | | 2.8 | | pF |
| SWITCHING PARAMETERS | | | | | | |
| Total Gate Charge (Note 1) | Q_G | $V_{DS}=400\text{V}$, $V_{GS}=10\text{V}$, $I_D=2\text{A}$ $I_G=1\text{mA}$ (Note 1, 2) | | 6.7 | | nC |
| Gate to Source Charge | Q_{GS} | | | 2.7 | | nC |
| Gate to Drain Charge | Q_{GD} | | | 0.9 | | nC |
| Turn-ON Delay Time (Note 1) | $t_{D(ON)}$ | $V_{DD}=100\text{V}$, $V_{GS}=10\text{V}$, $I_D=2\text{A}$, $R_G=25\Omega$ (Note 1, 2) | | 3.5 | | ns |
| Rise Time | t_R | | | 16 | | ns |
| Turn-OFF Delay Time | $t_{D(OFF)}$ | | | 17.6 | | ns |
| Fall-Time | t_F | | | 22.5 | | ns |
| SOURCE- DRAIN DIODE RATINGS AND CHARACTERISTICS | | | | | | |
| Maximum Continuous Drain-Source Diode Forward Current | I_S | | | | 2 | A |
| Maximum Pulsed Drain-Source Diode Forward Current | I_{SM} | | | | 4 | A |
| Drain-Source Diode Forward Voltage (Note 1) | V_{SD} | $I_S=2\text{A}$, $V_{GS}=0\text{V}$ | | | 1.4 | V |
| Body Diode Reverse Recovery Time | t_{rr} | $I_S=2\text{A}$, $V_{GS}=0\text{V}$, $di_f/dt=100\text{A}/\mu\text{s}$ | | 210 | | ns |
| Body Diode Reverse Recovery Charge | Q_{rr} | | | | 0.7 | |

Notes: 1. Pulse Test: Pulse width $\leq 300\mu\text{s}$, Duty cycle $\leq 2\%$.

2. Essentially independent of operating temperature.

TEST CIRCUITS AND WAVEFORMS

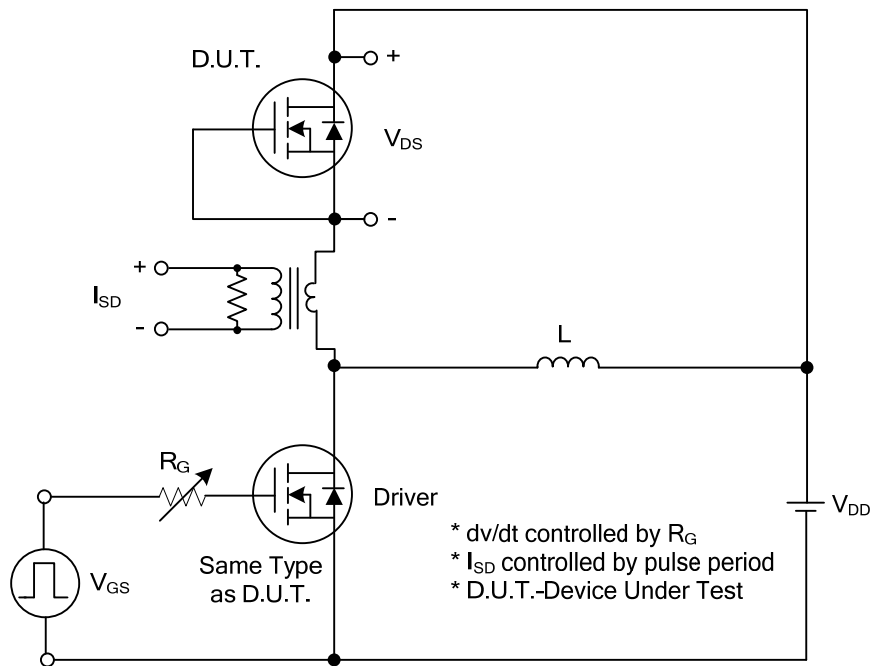

Peak Diode Recovery dv/dt Test Circuit

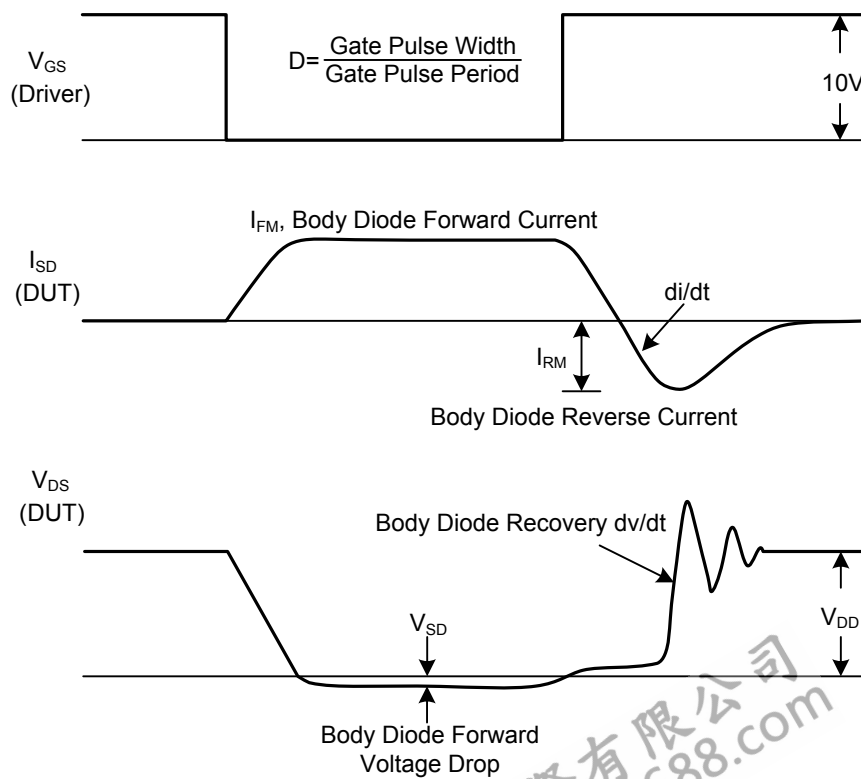

Peak Diode Recovery dv/dt Waveforms

TEST CIRCUITS AND WAVEFORMS

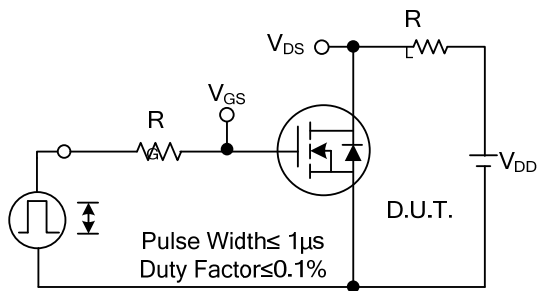

Switching Test Circuit

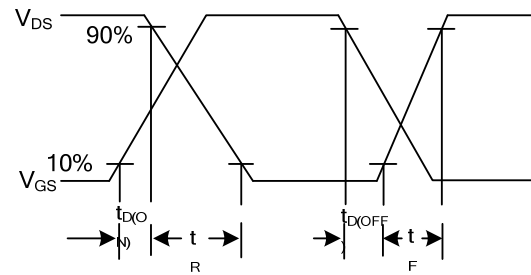

Switching Waveforms

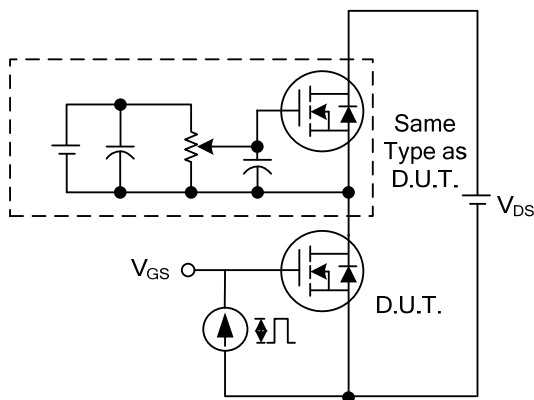

Gate Charge Test Circuit

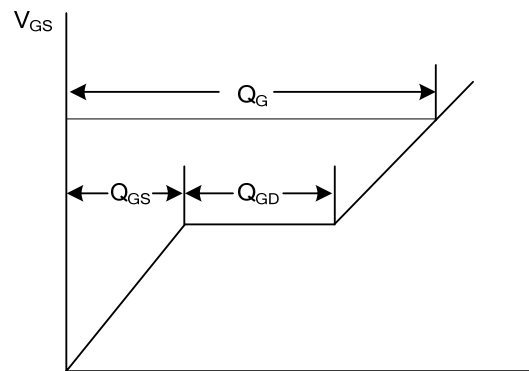

Charge

Gate Charge Waveform

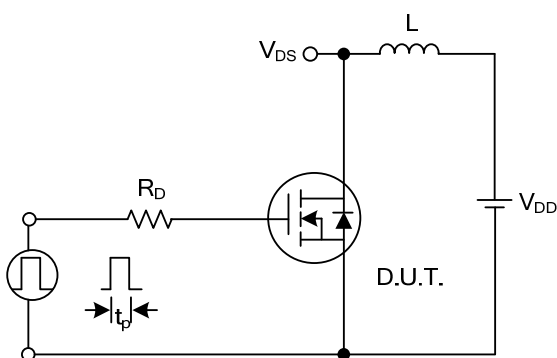

Unclamped Inductive Switching Test Circuit

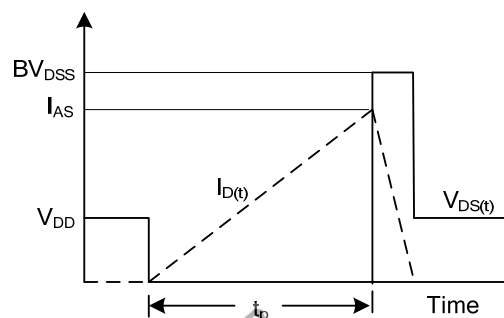

Unclamped Inductive Switching Waveforms

TYPICAL CHARACTERISTICS

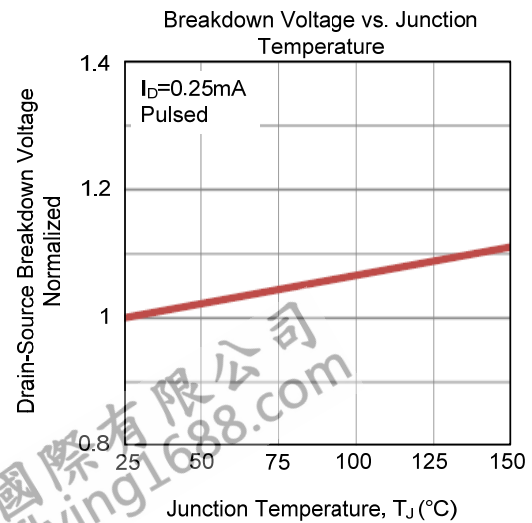
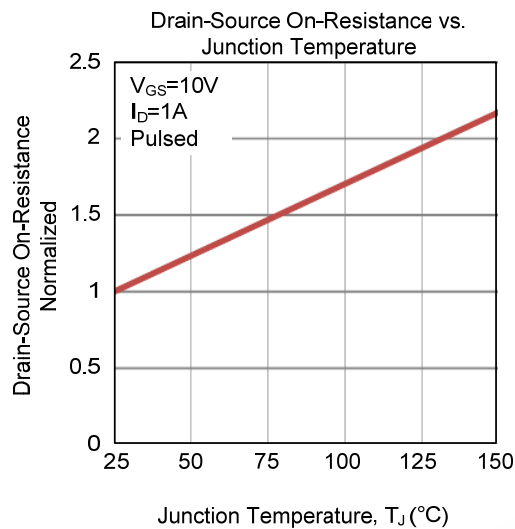
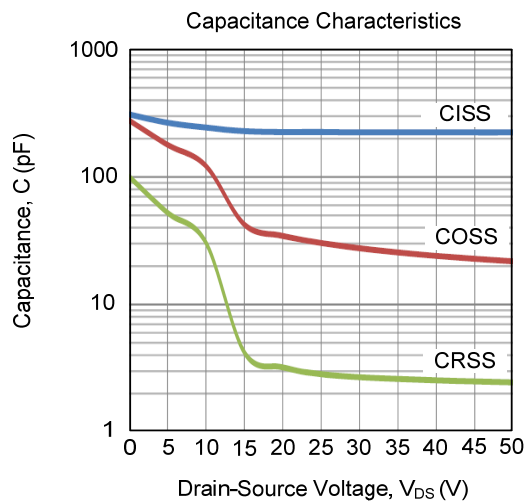
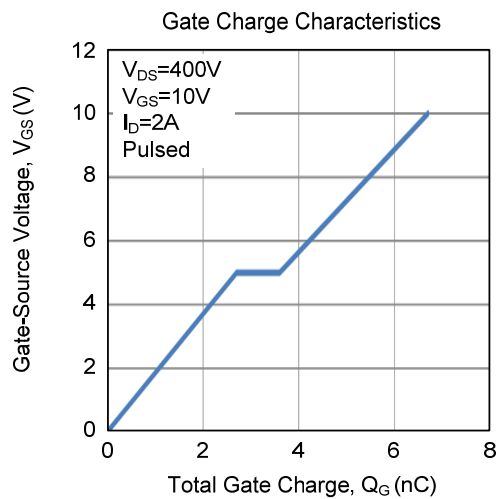
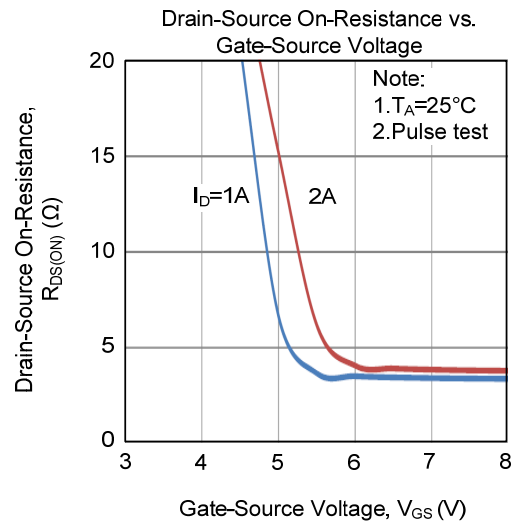
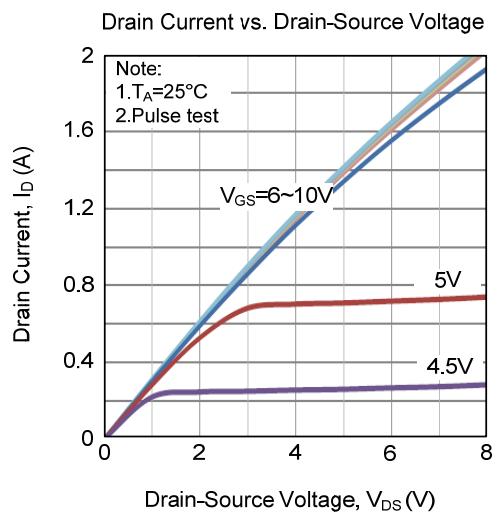

TYPICAL CHARACTERISTICS (Cont.)

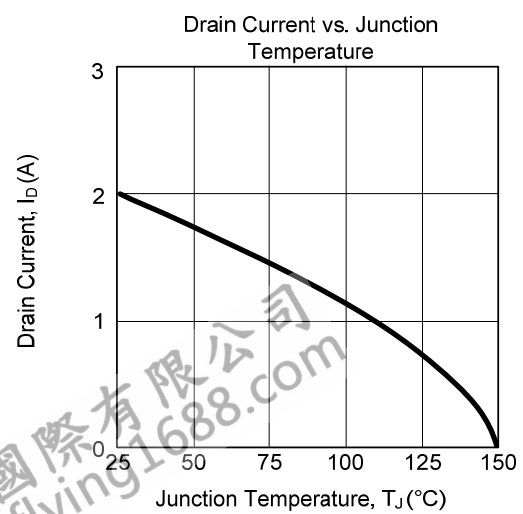
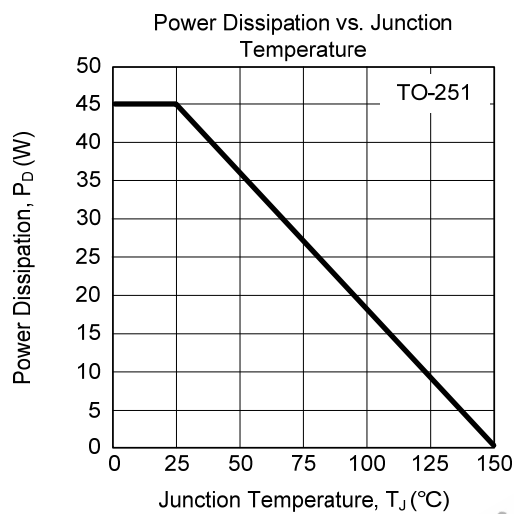
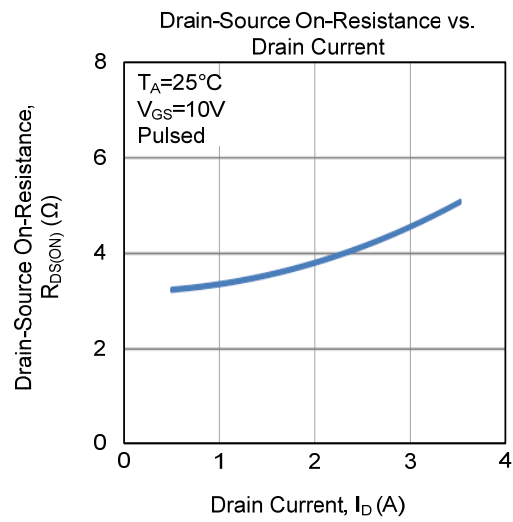
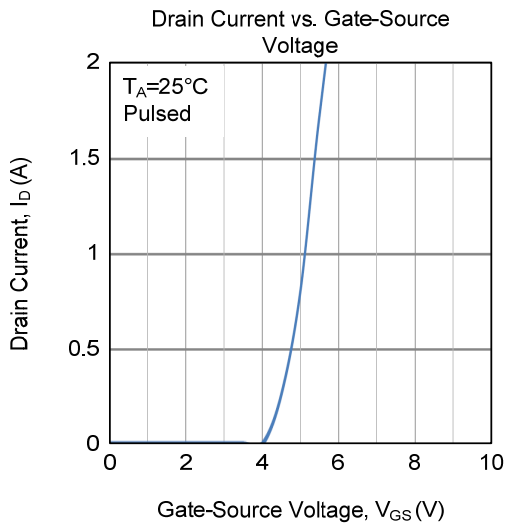
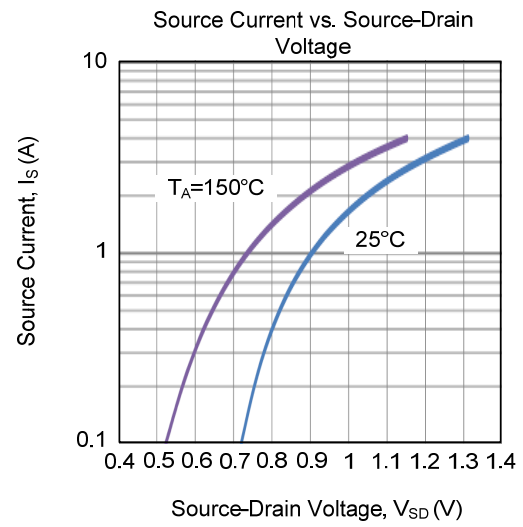
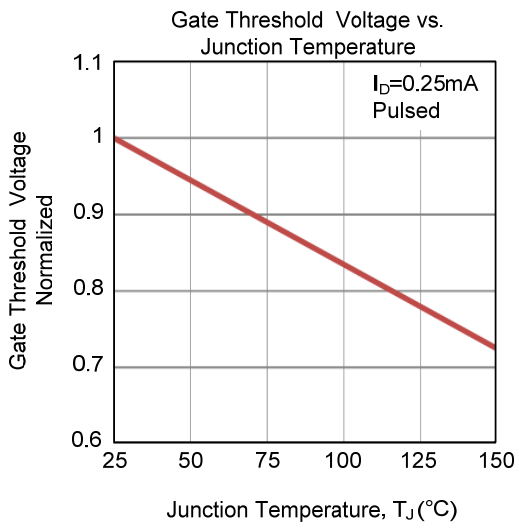

■ TYPICAL CHARACTERISTICS (Cont.)

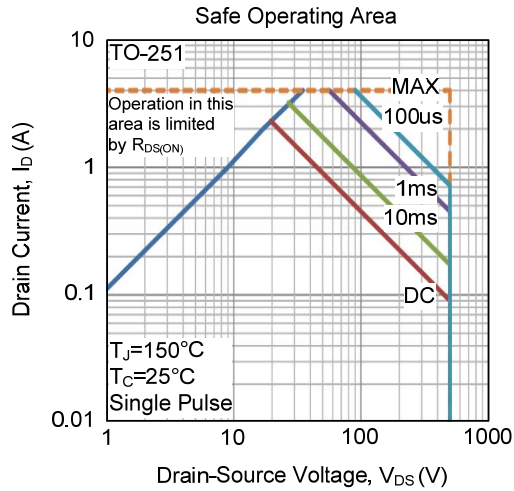

UTC assumes no responsibility for equipment failures that result from using products at values that exceed, even momentarily, rated values (such as maximum ratings, operating condition ranges, or other parameters) listed in products specifications of any and all UTC products described or contained herein. UTC products are not designed for use in life support appliances, devices or systems where malfunction of these products can be reasonably expected to result in personal injury. Reproduction in whole or in part is prohibited without the prior written consent of the copyright owner. UTC reserves the right to make changes to information published in this document, including without limitation specifications and product descriptions, at any time and without notice. This document supersedes and replaces all information supplied prior to the publication hereof.