



2N7002Z

Power MOSFET

300mA, 60V N-CHANNEL ENHANCEMENT MODE POWER MOSFET

DESCRIPTION

The UTC **2N7002Z** uses advanced technology to provide excellent $R_{DS(ON)}$, low gate charge and operation with low gate voltages. This device is suitable for use as a load switch or in PWM applications.

FEATURES

- * Low Reverse Transfer Capacitance
- * ESD Protected
- * Fast Switching Capability
- * Avalanche Energy Specified
- * Improved dv/dt Capability, High Ruggedness

SYMBOL

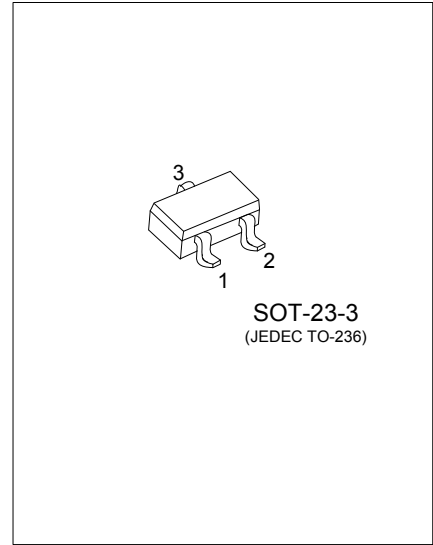
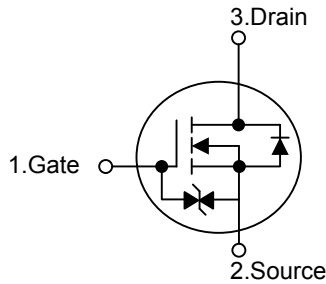

ORDERING INFORMATION

| Ordering Number | | Package | Pin Assignment | | | Packing |
|-----------------|----------------|----------|----------------|---|---|-----------|
| Lead Free | Halogen Free | | 1 | 2 | 3 | |
| 2N7002ZL-AE2-R | 2N7002ZG-AE2-R | SOT-23-3 | G | S | D | Tape Reel |

Note: Pin Assignment: G: Gate S: Source D: Drain

| | |
|--|---|
| <p>2N7002ZG-AE2-R</p> <p>(1) Packing Type (2) Package Type (3) Green Package</p> | <p>(1) R: Tape Reel (2) AE2: SOT-23-3 (3) G: Halogen Free and Lead Free, L: Lead Free</p> |
|--|---|

MARKING

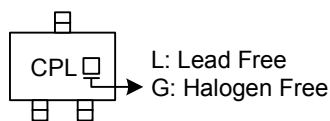

■ ABSOLUTE MAXIMUM RATINGS ($T_A=25^\circ\text{C}$, unless otherwise specified.)

| PARAMETER | SYMBOL | RATINGS | UNIT |
|---------------------------------------|---------------|------------|----------------------|
| Drain-Source Voltage | V_{DSS} | 60 | V |
| Gate-Source Voltage | V_{GSS} | ± 20 | V |
| Drain Current | Continuous | 300 | mA |
| | Pulse(Note 2) | 800 | |
| Power Dissipation | P_D | 225 | mW |
| Derating above $T_A=25^\circ\text{C}$ | | 1.6 | mW/ $^\circ\text{C}$ |
| Junction Temperature | T_J | +150 | $^\circ\text{C}$ |
| Storage Temperature | T_{STG} | -55 ~ +150 | $^\circ\text{C}$ |

Notes: 1. Absolute maximum ratings are those values beyond which the device could be permanently damaged.

Absolute maximum ratings are stress ratings only and functional device operation is not implied.

2. Pulse width $\leq 10\mu\text{s}$, Duty cycle $\leq 1\%$.

■ ELECTRICAL CHARACTERISTICS ($T_A=25^\circ\text{C}$, unless otherwise specified.)

| PARAMETER | SYMBOL | TEST CONDITIONS | MIN | TYP | MAX | UNIT |
|---|--------------|---|-----|------|----------|---------------|
| OFF CHARACTERISTICS | | | | | | |
| Drain-Source Breakdown Voltage | BV_{DSS} | $V_{GS}=0\text{V}$, $I_D=10\mu\text{A}$ | 60 | | | V |
| Drain-Source Leakage Current | I_{DSS} | $V_{DS}=60\text{V}$, $V_{GS}=0\text{V}$ | | | 1 | μA |
| Gate-Source Leakage Current | I_{GSS} | $V_{DS}=0\text{V}$, $V_{GS}=\pm 20\text{V}$ | | | ± 10 | μA |
| ON CHARACTERISTICS | | | | | | |
| Gate Threshold Voltage | $V_{GS(TH)}$ | $V_{DS}=10\text{V}$, $I_D=1\text{mA}$ | 1.0 | 1.85 | 2.5 | V |
| Static Drain-Source On-Resistance (Note) | $R_{DS(ON)}$ | $V_{GS}=10\text{V}$, $I_D=0.3\text{A}$ | | | 2.0 | Ω |
| | | $V_{GS}=5\text{V}$, $I_D=0.05\text{A}$ | | | 3.0 | Ω |
| DYNAMIC PARAMETERS | | | | | | |
| Input Capacitance | C_{ISS} | $V_{DS}=25\text{V}$, $V_{GS}=0\text{V}$, $f=1.0\text{MHz}$ | | | 50 | pF |
| Output Capacitance | C_{OSS} | | | | 25 | pF |
| Reverse Transfer Capacitance | C_{RSS} | | | | 5.0 | pF |
| SWITCHING PARAMETERS | | | | | | |
| Turn-ON Delay Time | $t_{D(ON)}$ | $I_D=0.2\text{A}$, $V_{DD}=30\text{V}$, $V_{GS}=10\text{V}$, | | 12 | 20 | ns |
| Turn-OFF Delay Time | $t_{D(OFF)}$ | $R_L=150\Omega$, $R_G=10\Omega$ | | 20 | 30 | ns |
| DRAIN-SOURCE DIODE CHARACTERISTICS AND MAXIMUM RATINGS | | | | | | |
| Maximum Continuous Drain-Source Diode Forward Current | I_S | | | | 300 | mA |
| Maximum Pulsed Drain-Source Diode Forward Current | I_{SM} | | | | 0.8 | A |
| Drain-Source Diode Forward Voltage | V_{SD} | $V_{GS}=0\text{V}$, $I_S=300\text{mA}$ (Note) | | 0.88 | 1.5 | V |

Note: Pulse width $\leq 300\mu\text{s}$, Duty cycle $\leq 1\%$

■ TEST CIRCUITS AND WAVEFORMS

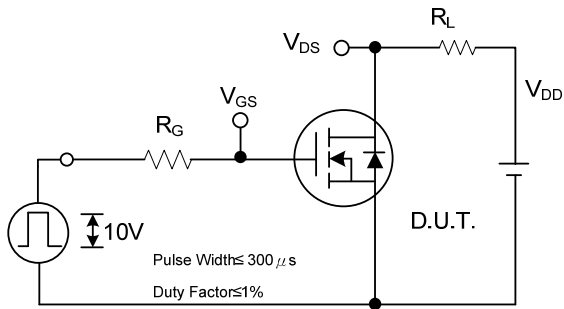

Switching Test Circuit

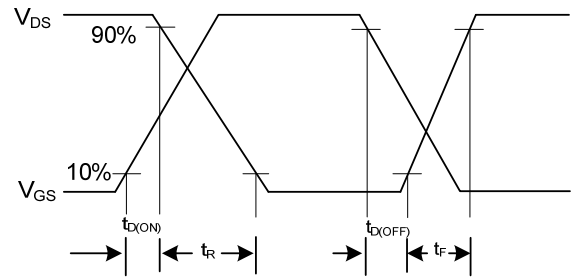

Switching Waveforms

■ TYPICAL CHARACTERISTICS

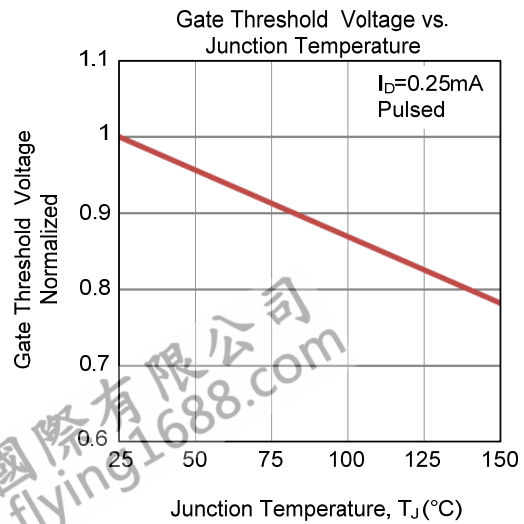
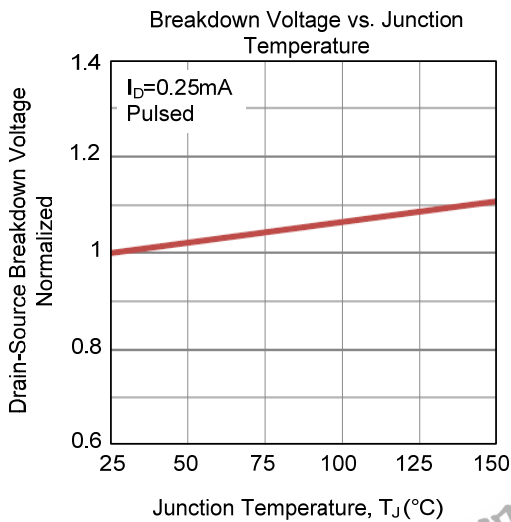
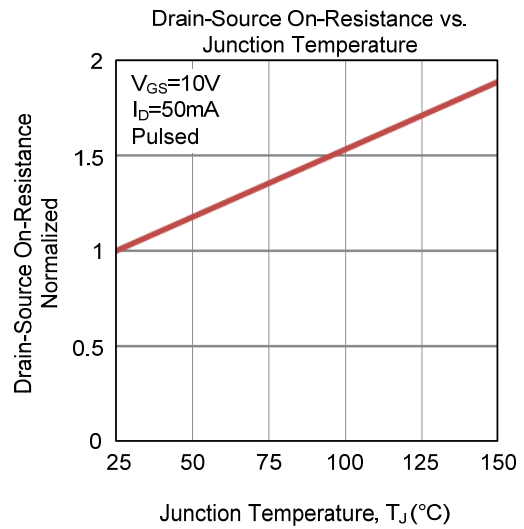
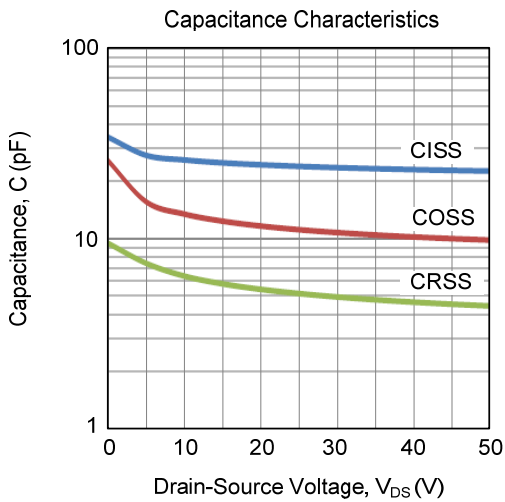
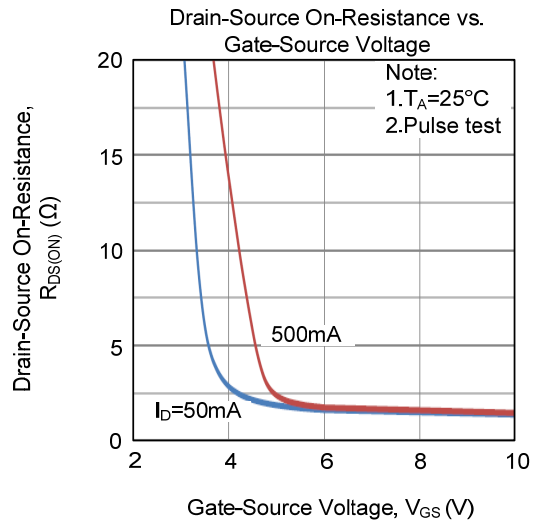
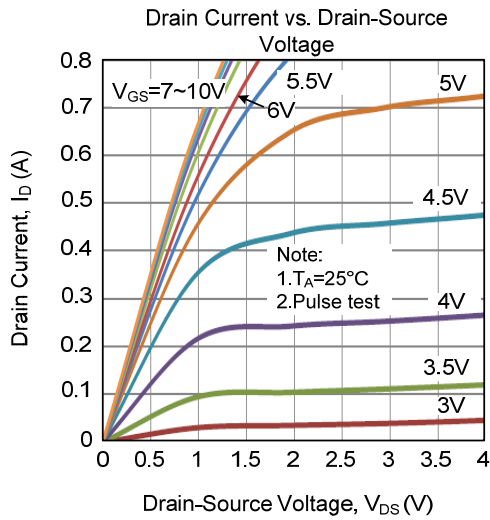

TYPICAL CHARACTERISTICS (Cont.)

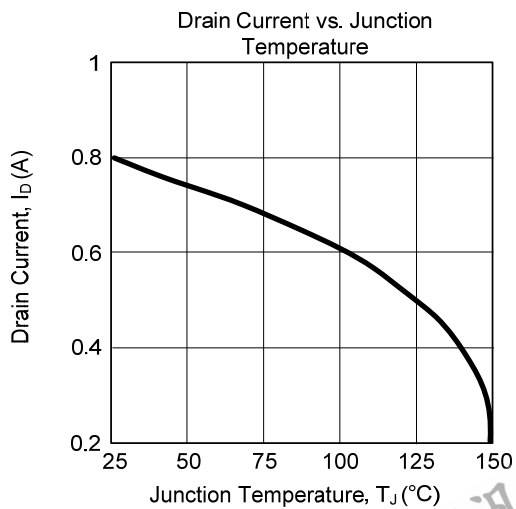
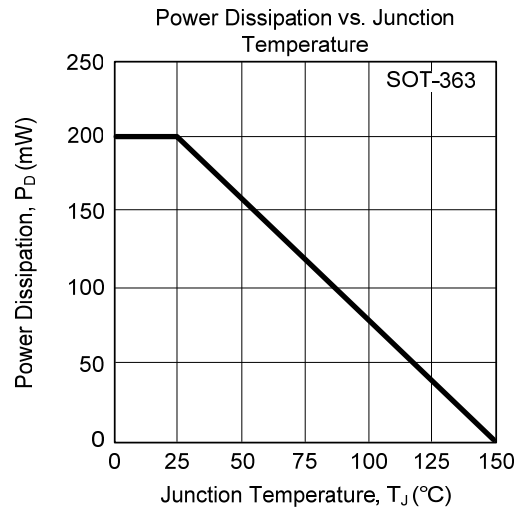
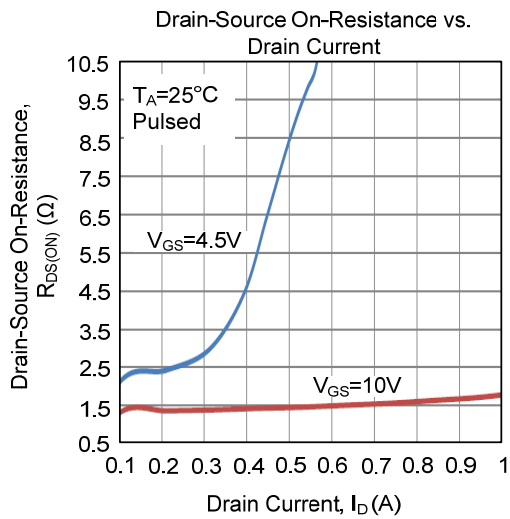
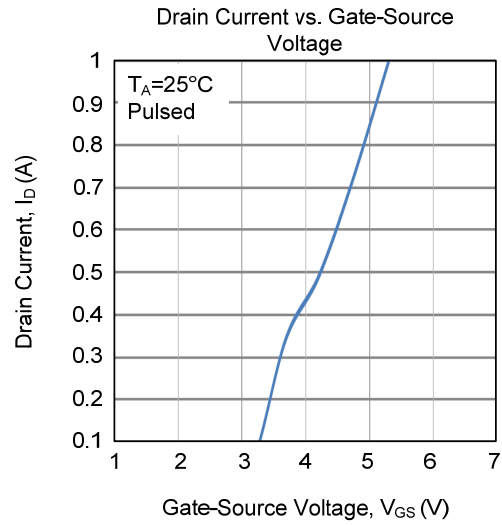
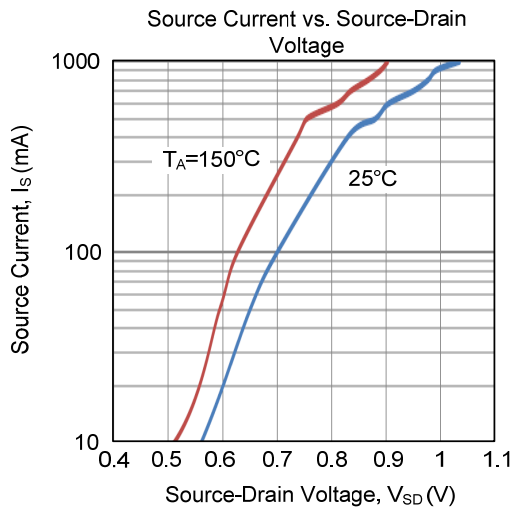

UTC assumes no responsibility for equipment failures that result from using products at values that exceed, even momentarily, rated values (such as maximum ratings, operating condition ranges, or other parameters) listed in products specifications of any and all UTC products described or contained herein. UTC products are not designed for use in life support appliances, devices or systems where malfunction of these products can be reasonably expected to result in personal injury. Reproduction in whole or in part is prohibited without the prior written consent of the copyright owner. UTC reserves the right to make changes to information published in this document, including without limitation specifications and product descriptions, at any time and without notice. This document supersedes and replaces all information supplied prior to the publication hereof.