



2N80Z

Preliminary

Power MOSFET

**2A, 800V N-CHANNEL
POWER MOSFET**

■ DESCRIPTION

The UTC **2N80Z** is an N-channel mode power MOSFET using UTC's advanced technology to provide costumers planar stripe and DMOS technology. This technology is specialized in allowing a minimum on-state resistance and superior switching performance. It also can withstand high energy pulse in the avalanche and commutation mode.

The UTC **2N80Z** is universally applied in high efficiency switch mode power supply.

■ FEATURES

- * $R_{DS(on)} < 6.3\Omega @ V_{GS}=10V, I_D=1.2A$
- * High switching speed

■ SYMBOL

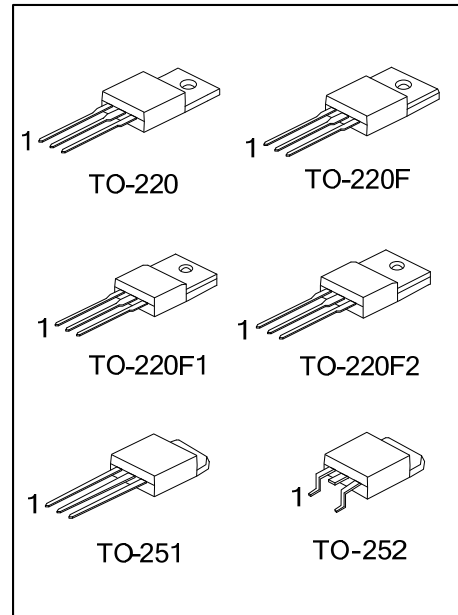
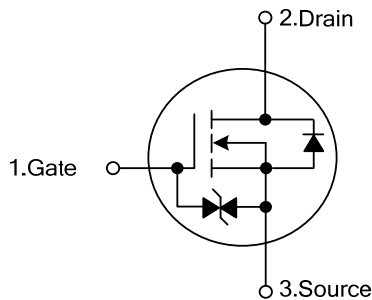

■ ORDERING INFORMATION

Ordering Number		Package	Pin Assignment			Packing
Lead Free	Halogen Free		1	2	3	
2N80ZL-TA3-T	2N80ZG-TA3-T	TO-220	G	D	S	Tube
2N80ZL-TF3-T	2N80ZG-TF3-T	TO-220F1	G	D	S	Tube
2N80ZL-TF1-T	2N80ZG-TF1-T	TO-220F2	G	D	S	Tube
2N80ZL-TF2-T	2N80ZG-TF2-T	TO-220F	G	D	S	Tube
2N80ZL-TM3-R	2N80ZG-TM3-R	TO-251	G	D	S	Tape Reel
2N80ZL-TN3-R	2N80ZG-TN3-R	TO-252	G	D	S	Tape Reel

Note: Pin Assignment: G: Gate D: Drain S: Source

<p>2N80ZL-TA3-T</p> <p>(1)Packing Type</p> <p>(2)Package Type</p> <p>(3)Green Package</p>	<p>(1) R: Tape Reel, T: Tube</p> <p>(2) TA3: TO-220, TF3: TO-220F, TF1: TO-220F1 TF2: TO-220F2, TM3: TO-251, TN3: TO-252</p> <p>(3) L: Lead Free, G: Halogen Free and Lead Free</p>
---	---

MARKING

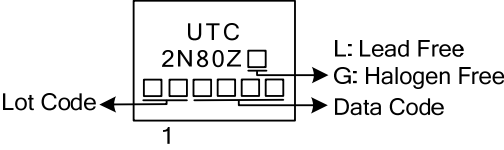

FLYING 汎翔國際有限公司
www.flying1688.com

■ ABSOLUTE MAXIMUM RATINGS ($T_c=25^\circ\text{C}$, unless otherwise specified)

PARAMETER		SYMBOL	RATINGS	UNIT
Drain-Source Voltage		V_{DSS}	800	V
Gate-Source Voltage		V_{GSS}	± 20	V
Avalanche Current (Note 2)		I_{AR}	2.4	A
Drain Current	Continuous	I_D	2.4	A
	Pulsed (Note 2)	I_{DM}	9.6	A
Avalanche Energy	Single Pulsed (Note 3)	E_{AS}	180	mJ
	Repetitive (Note 2)	E_{AR}	8.5	mJ
Peak Diode Recovery dv/dt (Note 4)		dv/dt	4.0	V/ns
Power Dissipation	TO-220	P_D	65	W
	TO-220F/TO-220F1		24	W
	TO-220F2			
	TO-251/TO-252		43	W
Junction Temperature		T_J	+150	$^\circ\text{C}$
Storage Temperature		T_{STG}	-55~+150	$^\circ\text{C}$

Notes: 1. Absolute maximum ratings are those values beyond which the device could be permanently damaged.

Absolute maximum ratings are stress ratings only and functional device operation is not implied.

2. Repetitive Rating: Pulse width limited by maximum junction temperature

3. $L = 59\text{mH}$, $I_{AS} = 2.4\text{A}$, $V_{DD} = 50\text{V}$, $R_G = 25\ \Omega$, Starting $T_J = 25^\circ\text{C}$

4. $I_{SD} \leq 2.4\text{A}$, $di/dt \leq 200\text{A}/\mu\text{s}$, $V_{DD} \leq BV_{DSS}$, Starting $T_J = 25^\circ\text{C}$

■ THERMAL DATA

PARAMETER		SYMBOL	RATINGS	UNIT
Junction to Ambient	TO-220/TO-220F	θ_{JA}	62.5	$^\circ\text{C}/\text{W}$
	TO-220F1/TO-220F2			
	TO-251/TO-252			
Junction to Case	TO-220	θ_{JC}	1.92	$^\circ\text{C}/\text{W}$
	TO-220F/TO-220F1		5.2	$^\circ\text{C}/\text{W}$
	TO-220F2			
	TO-251/TO-252		2.85	$^\circ\text{C}/\text{W}$

■ ELECTRICAL CHARACTERISTICS ($T_C=25^\circ\text{C}$, unless otherwise specified)

PARAMETER		SYMBOL	TEST CONDITIONS	MIN	TYP	MAX	UNIT
OFF CHARACTERISTICS							
Drain-Source Breakdown Voltage		BV_{DSS}	$I_D=250\mu\text{A}$, $V_{GS}=0\text{V}$	800			V
Breakdown Voltage Temperature Coefficient		$\Delta BV_{DSS}/\Delta T_J$	Reference to 25°C , $I_D=250\mu\text{A}$		0.9		$V/^\circ\text{C}$
Drain-Source Leakage Current		I_{DSS}	$V_{DS}=800\text{V}$, $V_{GS}=0\text{V}$			10	μA
			$V_{DS}=640\text{V}$, $T_C=125^\circ\text{C}$			100	
Gate- Source Leakage Current	Forward	I_{GSS}	$V_{GS}=+20\text{V}$, $V_{DS}=0\text{V}$			5	μA
	Reverse		$V_{GS}=-20\text{V}$, $V_{DS}=0\text{V}$			-5	μA
ON CHARACTERISTICS							
Gate Threshold Voltage		$V_{GS(TH)}$	$V_{DS}=V_{GS}$, $I_D=250\mu\text{A}$	3.0		5.0	V
Static Drain-Source On-State Resistance		$R_{DS(ON)}$	$V_{GS}=10\text{V}$, $I_D=1.2\text{A}$		4.8	6.3	Ω
Forward Transconductance (Note 1)		g_{FS}	$V_{DS}=50\text{V}$, $I_D=1.2\text{A}$		2.65		S
DYNAMIC PARAMETERS							
Input Capacitance		C_{ISS}	$V_{GS}=0\text{V}$, $V_{DS}=25\text{V}$, $f=1.0\text{MHz}$		425	550	pF
Output Capacitance		C_{OSS}			45	60	
Reverse Transfer Capacitance		C_{RSS}			5.5	7.0	
SWITCHING PARAMETERS							
Total Gate Charge		Q_G	$V_{GS}=10\text{V}$, $V_{DS}=640\text{V}$, $I_D=2.4\text{A}$ (Note 1,2)		12	15	nC
Gate to Source Charge		Q_{GS}			2.6		
Gate to Drain Charge		Q_{GD}			6.0		
Turn-ON Delay Time		$t_{D(ON)}$	$V_{DD}=400\text{V}$, $I_D=2.4\text{A}$, $R_G=25\Omega$ (Note 1,2)		12	35	ns
Rise Time		t_R			30	70	
Turn-OFF Delay Time		$t_{D(OFF)}$			25	60	
Fall-Time		t_F			28	65	
SOURCE- DRAIN DIODE RATINGS AND CHARACTERISTICS							
Maximum Continuous Drain-Source Diode Forward Current		I_S				2.4	A
Maximum Pulsed Drain-Source Diode Forward Current		I_{SM}				9.6	A
Drain-Source Diode Forward Voltage		V_{SD}	$I_S=2.4\text{A}$, $V_{GS}=0\text{V}$			1.4	V
Reverse Recovery Time (Note 1)		t_{RR}	$I_S=2.4\text{A}$, $V_{GS}=0\text{V}$,		480		ns
Reverse Recovery Charge (Note 1)		Q_{RR}	$di_F/dt=100\text{A}/\mu\text{s}$		2.0		

Notes: 1. Pulse Test: Pulse width $\leq 300\mu\text{s}$, Duty cycle $\leq 2\%$.

2. Essentially independent of operating temperature.

■ TEST CIRCUITS AND WAVEFORMS

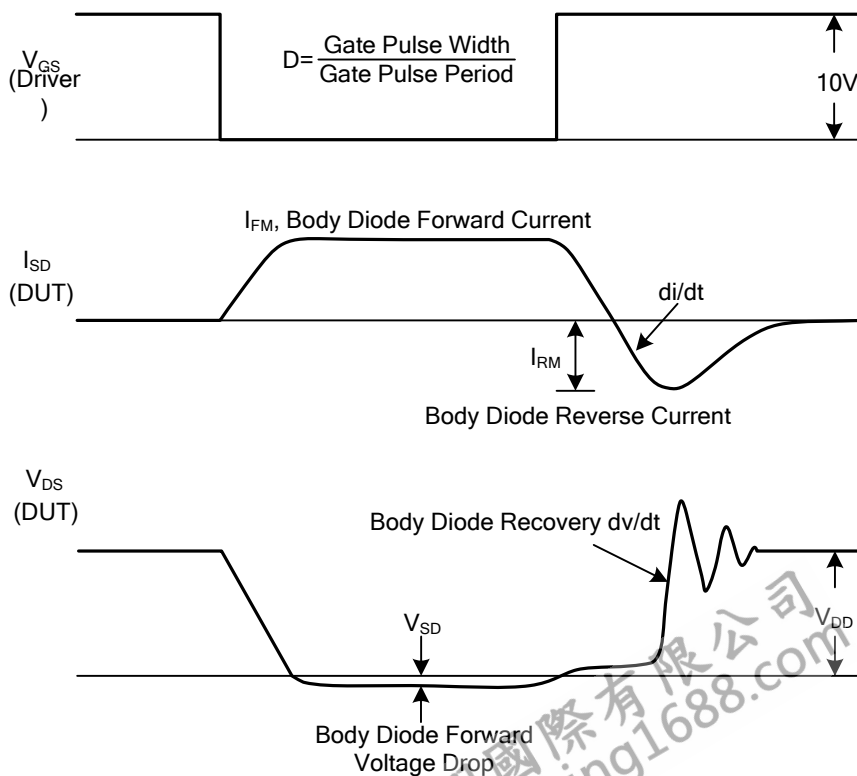
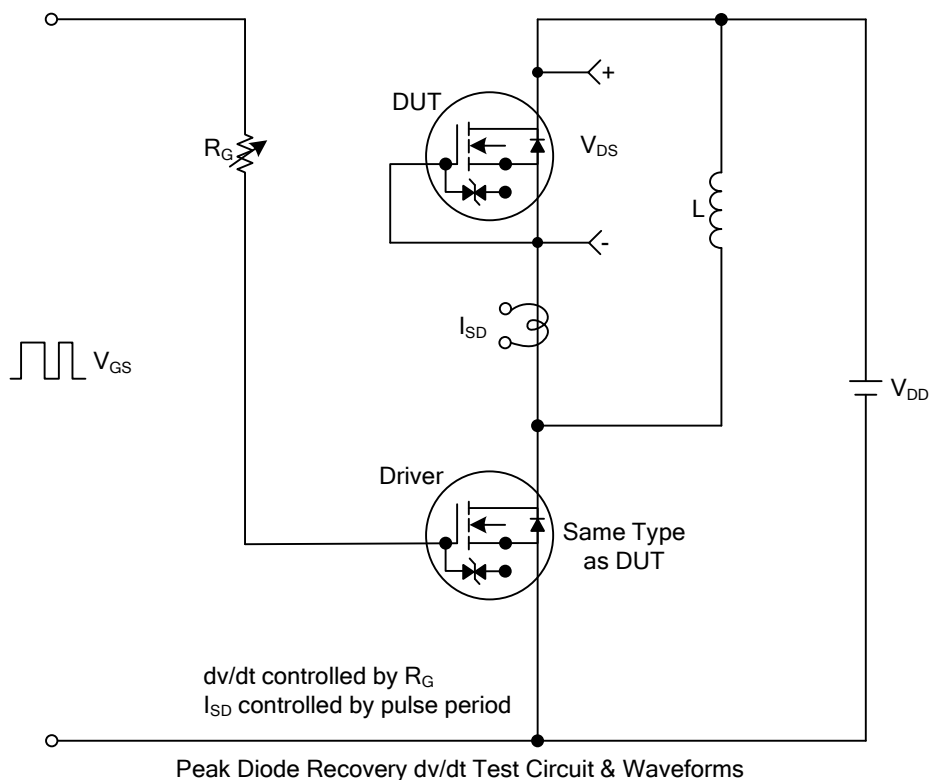

■ TEST CIRCUITS AND WAVEFORMS(Cont.)

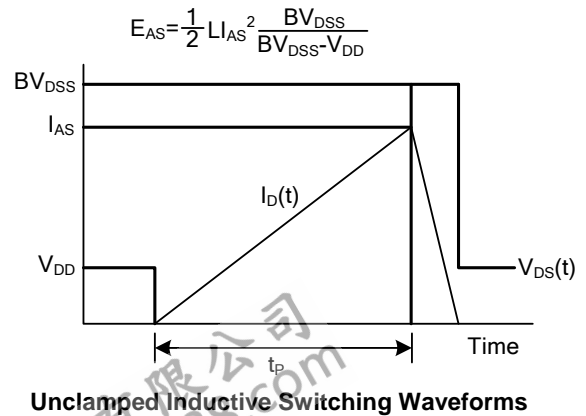
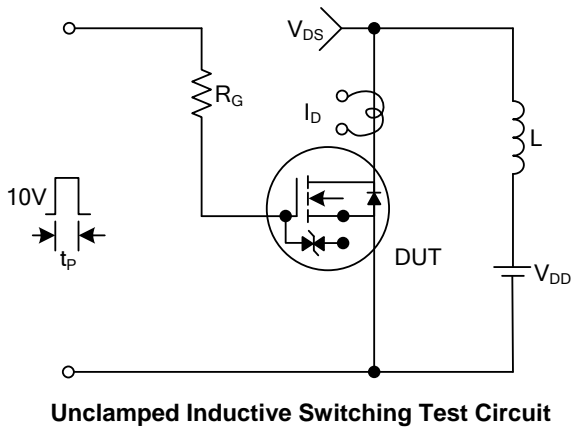
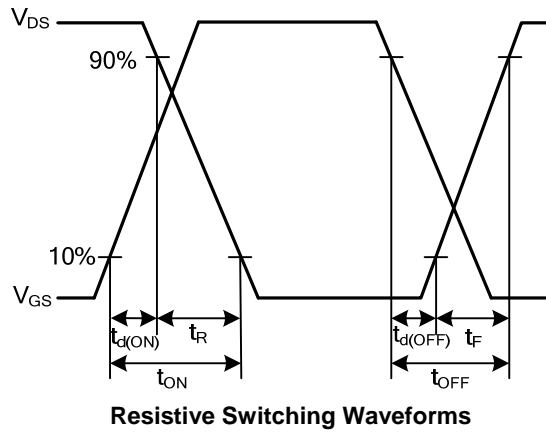
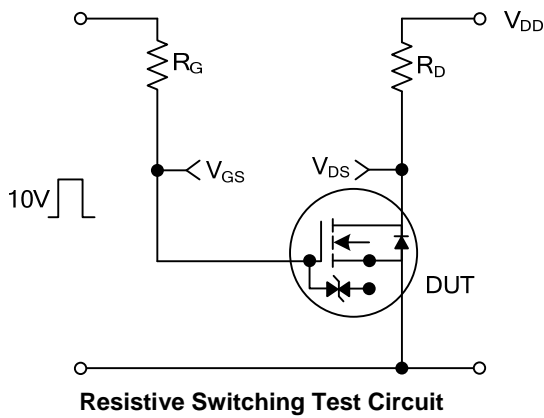
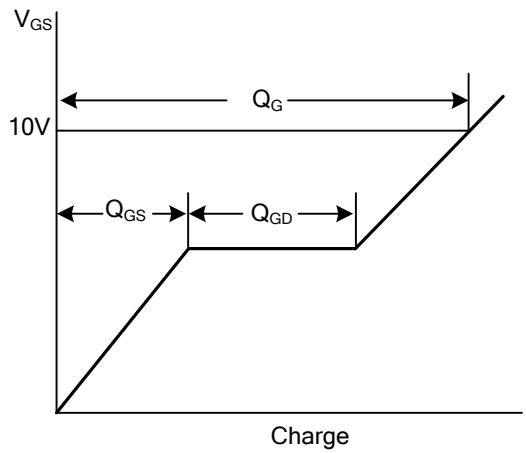
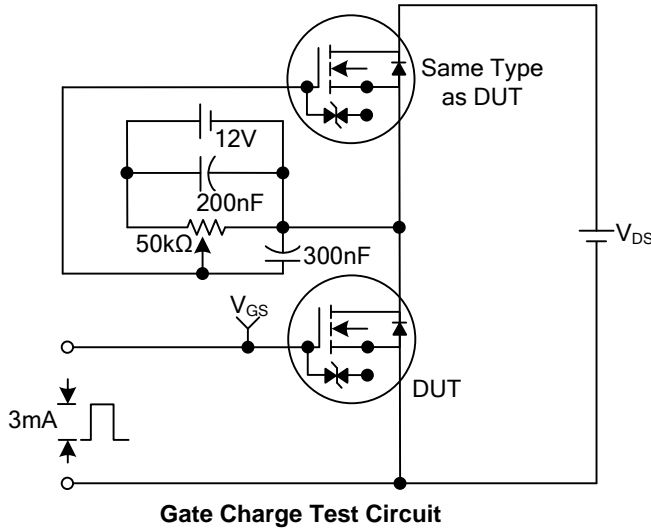

■ TYPICAL CHARACTERISTICS

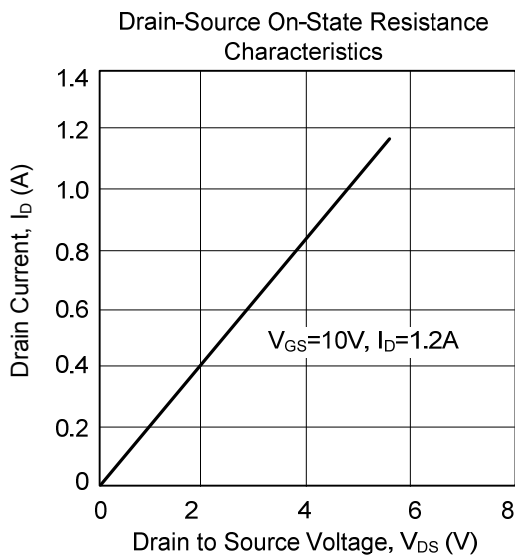
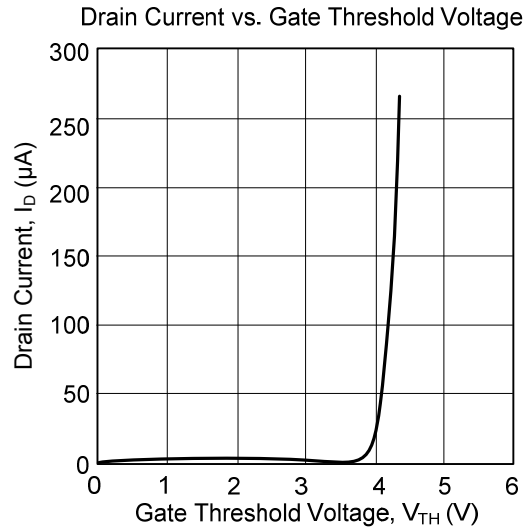
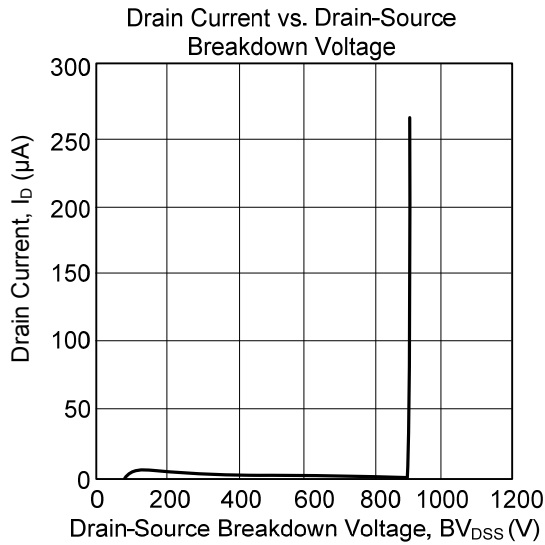

UTC assumes no responsibility for equipment failures that result from using products at values that exceed, even momentarily, rated values (such as maximum ratings, operating condition ranges, or other parameters) listed in products specifications of any and all UTC products described or contained herein. UTC products are not designed for use in life support appliances, devices or systems where malfunction of these products can be reasonably expected to result in personal injury. Reproduction in whole or in part is prohibited without the prior written consent of the copyright owner. The information presented in this document does not form part of any quotation or contract, is believed to be accurate and reliable and may be changed without notice.