



2NM90

Preliminary

Power MOSFET

2A, 900V N-CHANNEL SUPER-JUNCTION MOSFET

DESCRIPTION

The UTC 2NM90 is a Super Junction MOSFET Structure and is designed to have better characteristics, such as fast switching time, low gate charge, low on-state resistance and a high rugged avalanche characteristics. This power MOSFET is usually used at AC-DC converters for power applications.

FEATURES

- * $R_{DS(ON)} \leq 5.3 \Omega @ V_{GS}=10V, I_D=1.0A$
- * Fast switching capability
- * Avalanche energy tested
- * Improved dv/dt capability, high ruggedness

SYMBOL

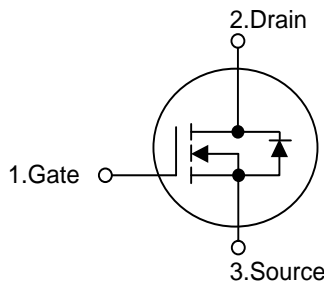

ORDERING INFORMATION

Ordering Number		Package	Pin Assignment			Packing
Lead Free	Halogen Free		1	2	3	
2NM90L-AA2-R	2NM90G-AA2-R	SOT-223-2	G	D	S	Tape Reel
2NM90L-AA3-R	2NM90G-AA3-R	SOT-223	G	D	S	Tape Reel
2NM90L-TA3-T	2NM90G-TA3-T	TO-220	G	D	S	Tube
2NM90L-TF1-T	2NM90G-TF1-T	TO-220F1	G	D	S	Tube
2NM90L-TF2-T	2NM90G-TF2-T	TO-220F2	G	D	S	Tube
2NM90L-TM3-T	2NM90G-TM3-T	TO-251	G	D	S	Tube
2NM90L-TMS2-T	2NM90G-TMS2-T	TO-251S2	G	D	S	Tube
2NM90L-TN3-R	2NM90G-TN3-R	TO-252	G	D	S	Tape Reel

Note: Pin Assignment: G: Gate D: Drain S: Source

<p>2NM90G-AA3-R</p> <p>(1) Packing Type</p> <p>(2) Package Type</p> <p>(3) Green Package</p>	<p>(1) R: Tape Reel, T: Tube</p> <p>(2) AA2: SOT-223-2, AA3: SOT-223, TA3: TO-220, TF1: TO-220F1, TF2: TO-220F2, TM3: TO-251, TMS2: TO-251S2, TN3: TO-252</p> <p>(3) G: Halogen Free and Lead Free, L: Lead Free</p>
--	--

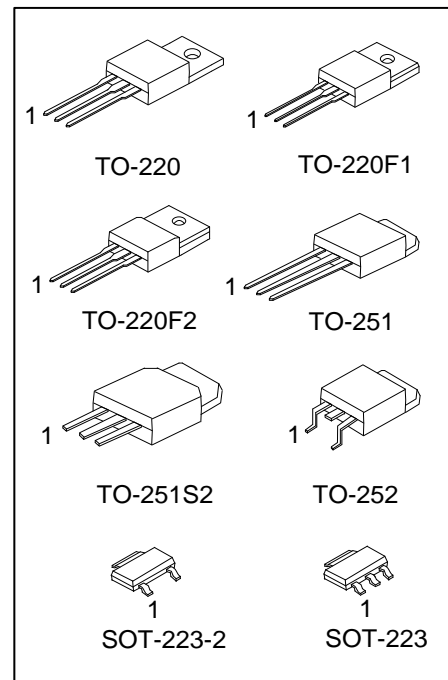

MARKING

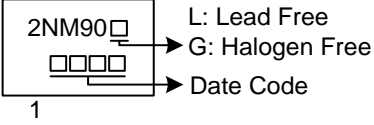
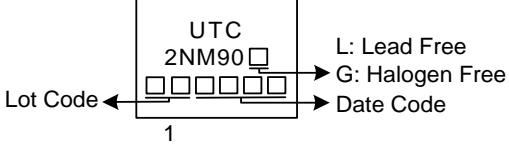
SOT-223-2 / SOT-223	TO-220 / TO-220F1 / TO-220F2 TO-251 / TO-251S2 / TO-252
 <p>2NM90 L: Lead Free G: Halogen Free Date Code 1</p>	 <p>UTC 2NM90 L: Lead Free G: Halogen Free Date Code Lot Code 1</p>

■ **ABSOLUTE MAXIMUM RATINGS** ($T_C=25^\circ\text{C}$, unless otherwise specified)

PARAMETER		SYMBOL	RATINGS	UNIT
Drain-Source Voltage		V_{DSS}	900	V
Gate-Source Voltage		V_{GSS}	± 30	V
Continuous Drain Current	Continuous	I_D	2.0	A
Pulsed Drain Current	Pulsed (Note 2)	I_{DM}	8.0	A
Avalanche Current (Note 2)		I_{AR}	1.0	A
Single Pulsed Avalanche Energy	Single Pulsed (Note 3)	E_{AS}	80	mJ
Peak Diode Recovery dv/dt (Note 4)		dv/dt	1.47	V/ns
Power Dissipation	SOT-223-2/SOT-223	P_D	2	W
	TO-220		34	W
	TO-220F1/TO-220F2		21	W
	TO-251S2/TO-251		22	W
	TO-252			
Junction Temperature		T_J	+150	$^\circ\text{C}$
Storage Temperature		T_{STG}	-55 ~ +150	$^\circ\text{C}$

Notes: 1. Absolute maximum ratings are those values beyond which the device could be permanently damaged.

Absolute maximum ratings are stress ratings only and functional device operation is not implied.

2. Repetitive Rating: Pulse width limited by maximum junction temperature.

3. $L = 159\text{mH}$, $I_{AS} = 1.0\text{A}$, $V_{DD} = 50\text{V}$, $R_G = 25\Omega$, Starting $T_J = 25^\circ\text{C}$.

4. $I_{SD} \leq 2.0\text{A}$, $di/dt \leq 200\text{A}/\mu\text{s}$, $V_{DD} \leq BV_{DSS}$, Starting $T_J = 25^\circ\text{C}$.

■ **THERMAL DATA**

PARAMETER		SYMBOL	RATING	UNIT
Junction to Ambient	SOT-223-2/SOT-223	θ_{JA}	150	$^\circ\text{C}/\text{W}$
	TO-220/TO-220F1		62.5	$^\circ\text{C}/\text{W}$
	TO-220F2			
	TO-251S2/TO-252		110	$^\circ\text{C}/\text{W}$
Junction to Case	SOT-223-2/SOT-223	θ_{JC}	62.5 (Note)	$^\circ\text{C}/\text{W}$
	TO-220		3.68	$^\circ\text{C}/\text{W}$
	TO-220F1/TO-220F2		5.95	$^\circ\text{C}/\text{W}$
	TO-251S2/TO-251		5.68 (Note)	$^\circ\text{C}/\text{W}$
	TO-252			

Note: Device mounted on FR-4 substrate PC board, 2oz copper, with 1inch square copper plate.

■ **ELECTRICAL CHARACTERISTICS** ($T_J=25^\circ\text{C}$, unless otherwise specified)

PARAMETER	SYMBOL	TEST CONDITIONS	MIN	TYP	MAX	UNIT
OFF CHARACTERISTICS						
Drain-Source Breakdown Voltage	BV_{DSS}	$V_{GS} = 0V, I_D = 250\mu A$	900			V
Drain-Source Leakage Current	I_{DSS}	$V_{DS} = 900V, V_{GS} = 0V$			10	μA
Gate-Source Leakage Current	Forward	I_{GSS}			100	nA
	Reverse					
		$V_{GS} = -30V, V_{DS} = 0V$			-100	nA
ON CHARACTERISTICS						
Gate Threshold Voltage	$V_{GS(TH)}$	$V_{DS} = V_{GS}, I_D = 250\mu A$	2.5		4.5	V
Static Drain-Source On-State Resistance	$R_{DS(ON)}$	$V_{GS} = 10V, I_D = 1.0A$			5.3	Ω
DYNAMIC CHARACTERISTICS						
Input Capacitance	C_{ISS}	$V_{GS}=0V, V_{DS}=25V, f=1.0MHz$		205		pF
Output Capacitance	C_{OSS}			100		pF
Reverse Transfer Capacitance	C_{RSS}			5		pF
SWITCHING CHARACTERISTICS						
Total Gate Charge (Note 1)	Q_G	$V_{DS}=50V, I_D=1.3A, I_G=100\mu A$ $V_{GS}=10V$ (Note 1,2)		35		nC
Gate to Source Charge	Q_{GS}			3.5		nC
Gate to Drain Charge	Q_{GD}			6.5		nC
Turn-ON Delay Time (Note 1)	$t_{D(ON)}$	$V_{DD} = 30V, I_D = 0.5A, R_G = 25\Omega,$ $V_{GS}=10V$ (Note 1,2)		38		nS
Rise Time	t_R			40		nS
Turn-OFF Delay Time	$t_{D(OFF)}$			100		nS
Fall-Time	t_F			30		nS
SOURCE- DRAIN DIODE RATINGS AND CHARACTERISTICS						
Maximum Body-Diode Continuous Current	I_S				2.0	A
Maximum Body-Diode Pulsed Current	I_{SM}				8.0	A
Drain-Source Diode Forward Voltage (Note 1)	V_{SD}	$I_S=2.0A, V_{GS}=0V$			1.4	V
Body Diode Reverse Recovery Time (Note 1)	t_{rr}	$I_S=2.0A, V_{GS}=0V,$ $dI_F/dt=100A/\mu s$		400		nS
Body Diode Reverse Recovery Charge	Q_{rr}			2.06		μC

Notes: 1. Pulse Test : Pulse width $\leq 300\mu s$, Duty cycle $\leq 2\%$.

2. Essentially independent of operating ambient temperature.

■ TEST CIRCUITS AND WAVEFORMS

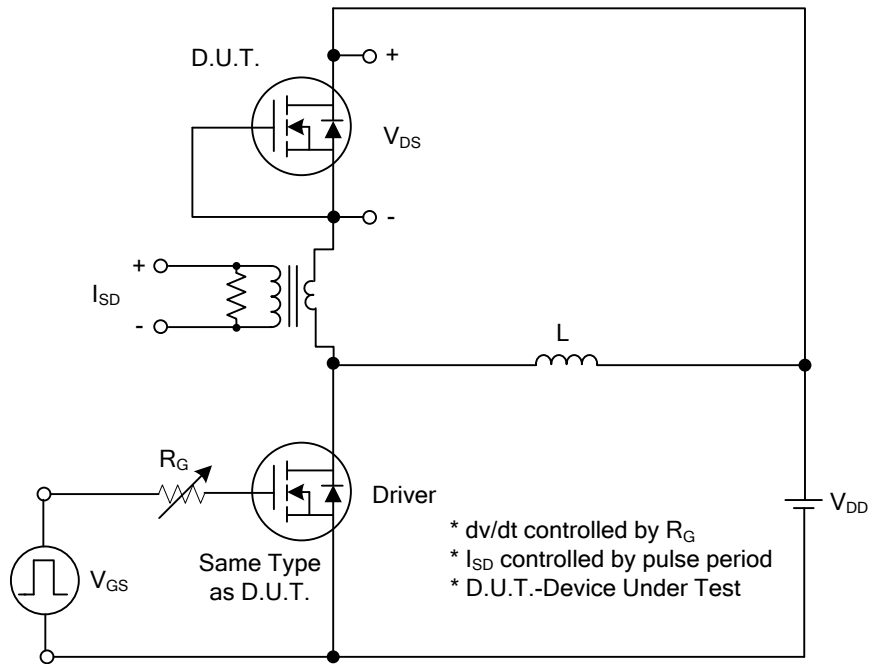

Peak Diode Recovery dv/dt Test Circuit

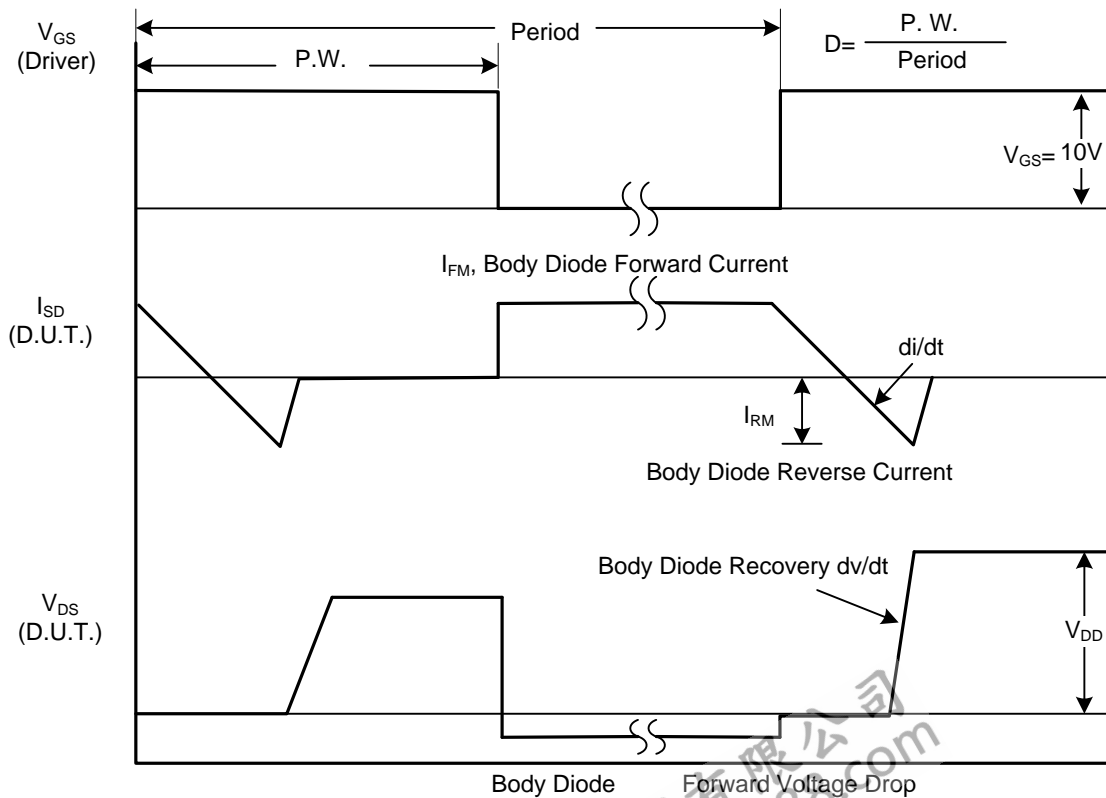

Peak Diode Recovery dv/dt Waveforms

■ TEST CIRCUITS AND WAVEFORMS (Cont.)

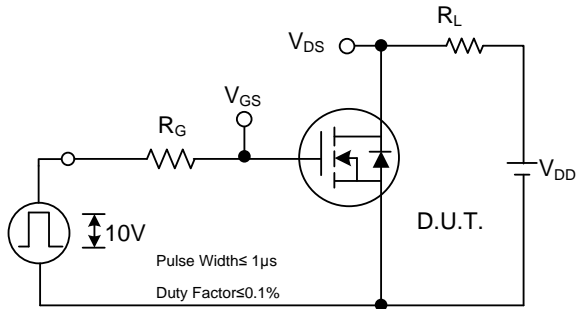

Switching Test Circuit

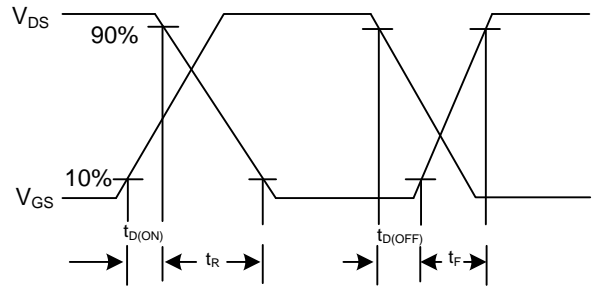

Switching Waveforms

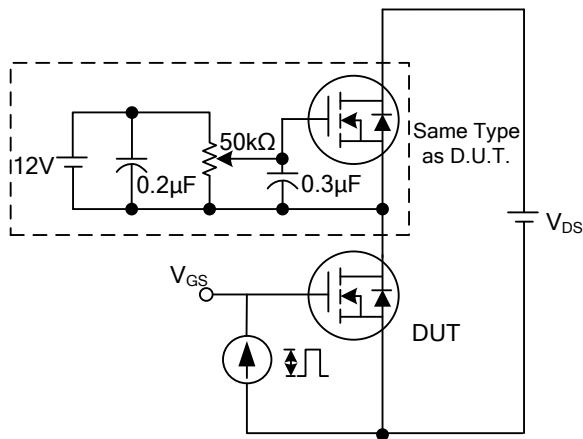

Gate Charge Test Circuit

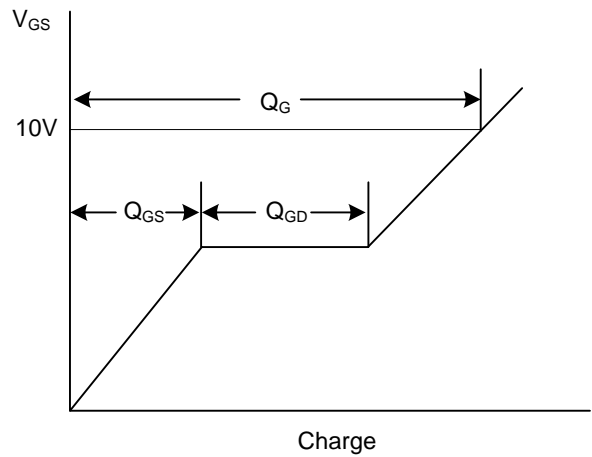

Gate Charge Waveform

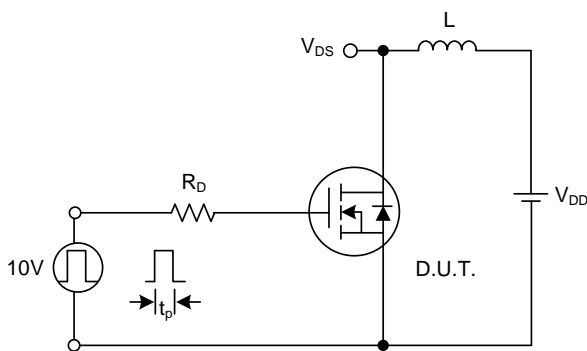

Unclamped Inductive Switching Test Circuit

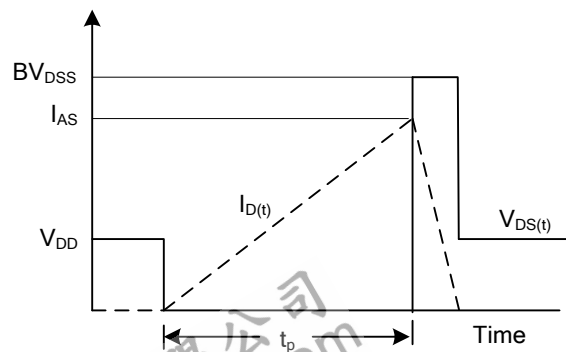

Unclamped Inductive Switching Waveforms

UTC assumes no responsibility for equipment failures that result from using products at values that exceed, even momentarily, rated values (such as maximum ratings, operating condition ranges, or other parameters) listed in products specifications of any and all UTC products described or contained herein. UTC products are not designed for use in life support appliances, devices or systems where malfunction of these products can be reasonably expected to result in personal injury. Reproduction in whole or in part is prohibited without the prior written consent of the copyright owner. UTC reserves the right to make changes to information published in this document, including without limitation specifications and product descriptions, at any time and without notice. This document supersedes and replaces all information supplied prior to the publication hereof.