

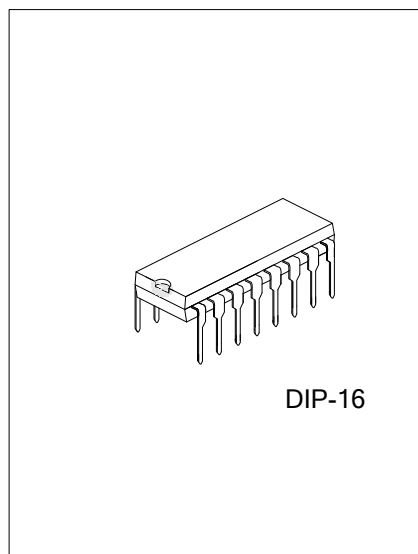

3521

CMOS IC

PWM CONTROLLER WITH SUPERVISORY CIRCUIT FOR SWITCHING POWER SUPPLY



DIP-16

DESCRIPTION

UTC **3521** PWM controller is designed for switching mode power supply for PCs. It provides all the functions necessary to monitor and control the output of the power supply. Remote ON/OFF control, power good circuitry, some protection features against over-voltage and over-power are implements.

FEATURES

- * Over-Voltage Protection for 3.3V, 5V and 12V
- * Under-Voltage Detection for 3.3V, 5V and 12V
- * Over-Power Protection
- * Remote ON/OFF Function
- * Power Good Circuitry
- * Delay Time for PG Signal
- * Delay Time for Over-Voltage and Under-Voltage Protection
- * On-Chip Oscillator and Error Amplifier

ORDERING INFORMATION

Ordering Number		Package	Packing
Lead Free Plating	Halogen Free		
3521L-D16-T	3521G-D16-T	DIP-16	Tube

<p>3521L-D16-T</p> <p>(1)Packing Type (2)Package Type (3)Lead Free</p>	<p>(1) T: Tube (2) D16: DIP-16 (3) L: Lead Free, G: Halogen Free</p>
--	--



■ PIN CONFIGURATION

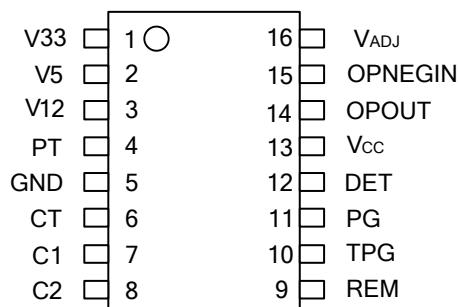

■ PIN DESCRIPTION

PIN NO.	PIN NAME	TYPE	FUNCTIONS
1	V33	I	OVP/UVI Input For 3.3V
2	V5	I	OVP/UVI Input For 5V
3	V12	I	OVP/UVI Input For 12V
4	PT	I	Additional OVP Protection
5	GND	P	Ground
6	CT		Cap FOR Oscillation Frequency
7	C1	O	Output 1
8	C2	O	Output 2
9	REM	I	Remote ON/OFF Pin.
10	TPG		Power Good Delay Time Setting
11	PG	O	Power Good Signal Out.
12	DET	I	Power Good Signal Detection Input
13	V _{CC}	P	Supply Voltage For IC
14	OPOUT	O	OP AMP Output
15	OPNEGIN	I	OP AMP Negative Input
16	V _{ADJ}	I	Voltage Adjust Pin

■ BLOCK DIAGRAM

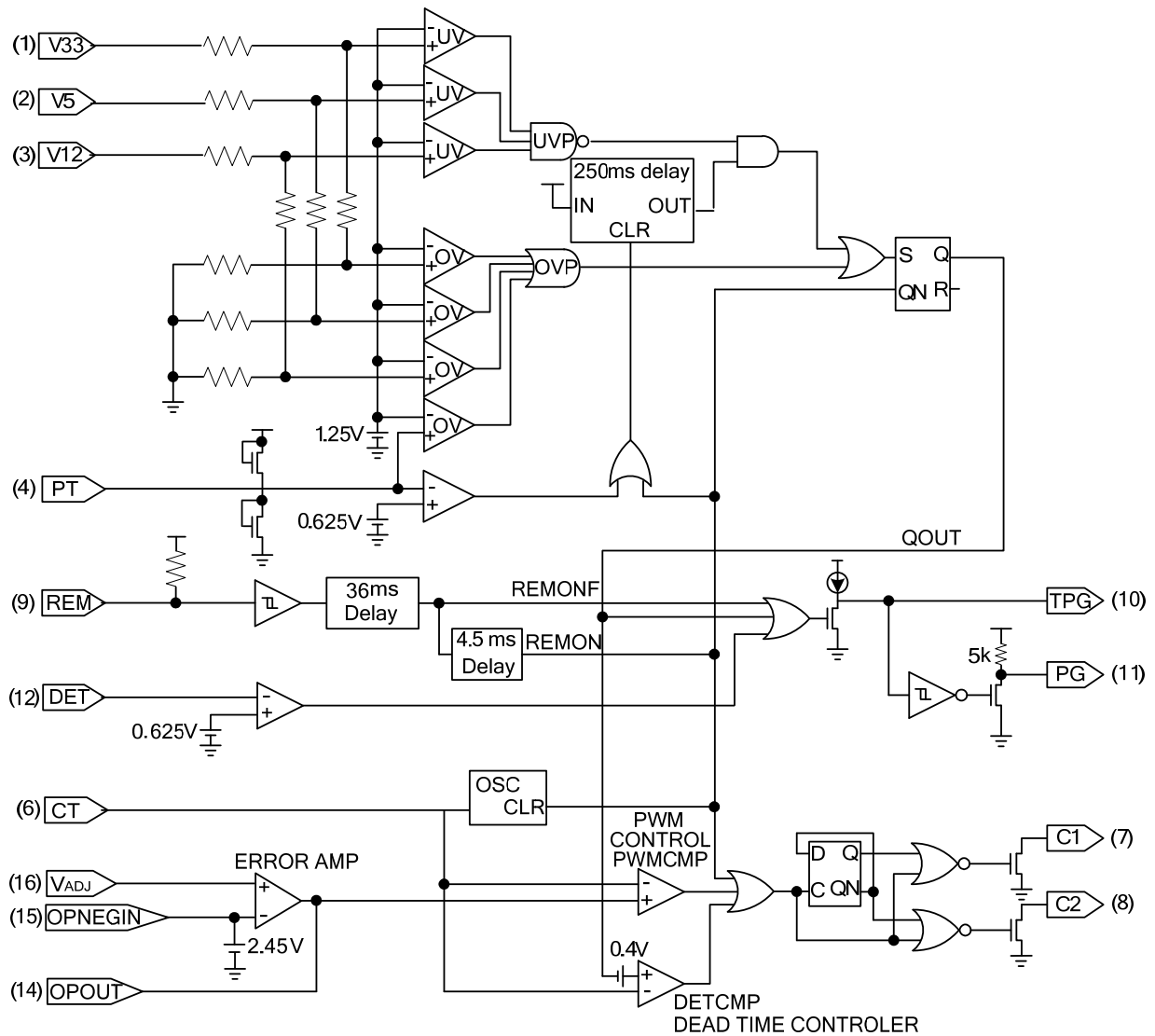

■ ABSOLUTE MAXIMUM RATINGS ($V_{CC}=5.5V$, unless otherwise specified)

PARAMETER	SYMBOL	RATINGS	UNIT
Supply Voltage	V_{CC}	5.5	V
Drain Output Voltage	V_{CC1}, V_{CC2}	5.5	V
Drain Output Current	I_{CC1}, I_{CC2}	200	mA
Power Dissipation	P_D	200	mW
Operating Temperature	T_{OPR}	-10 ~ +70	°C
Storage Temperature	T_{STG}	-65 ~ +150	°C

Note: Absolute maximum ratings are those values beyond which the device could be permanently damaged. Absolute maximum ratings are stress ratings only and functional device operation is not implied.

■ ELECTRICAL CHARACTERISTICS ($T_a=25^\circ C$, $V_{CC}=5V$, unless otherwise specified)

PARAMETER	SYMBOL	TEST CONDITIONS	MIN	TYP	MAX	UNIT
DEAD TIME CONTROL SECTION						
Input Threshold Voltage	$V_{I(THR)}$	ZERO DUTY CYCLE		3.0	3.5	V
		MAX. DUTY CYCLE		0.1		
ERROR AMP SECTION						
Opneg Bias Voltage		OPNEG OPEN	2.35	2.45	2.55	V
Close Loop Voltage Gain	G_{VC}	0.5V ~ 3.5V		65		dB
Cross Over Point		0dB		320		KHz
OUTPUT SECTION						
Output Saturation Voltage	V_{DSSAT}	$I_D=200mA$		1.1	1.3	V
Drain Off-State Current	$I_{D(OFF)}$	$V_{CC}=V_D=V_S=0V$		2	10	μA
Rising Time	t_R	$R_{PULL-UP}=1 K\Omega$		100	200	ns
Falling Time	t_F	$R_{PULL-UP}=1 K\Omega$		50	200	ns
PROTECTION SECTION						
Over Voltage Protection (OVP)	V33		3.8	4.1	4.4	V
	V5		5.8	6.2	6.6	
	V12		4.38	4.64	4.90	
	P_T		1.2	1.25	1.3	
Under Voltage Protection (UVP)	V33		1.78	1.98	2.18	V
	V5		2.70	3.00	3.30	
	V12		2.11	2.37	2.63	
UVP Disable Voltage	P_T		0.54	0.62	0.70	V
UVP Delay Time	t_{DLY}		100	250	500	ms
REMOTE ON/OFF SECTION						
REM High Input Voltage	V_{IH}		2.0			V
REM Low Input Voltage	V_{IL}				0.8	V
REM Pull High Voltage	$V_{H(PULL)}$		2.0		5.25	V
REM Delay Time	t_{DLY}		30	36	42	ms
REM Off Delay Time	$t_{DLY(OFF)}$		3.5	4.5	5.5	ms
POWER GOOD SECTION						
Detecting Input Voltage	$V_{I(DET)}$		0.54	0.62	0.70	V
Output Saturation Voltage	$V_{O(SAT)}$	$I_{PG}=10mA$		0.2	0.4	V
Charging Current For TPG	I_{CHAR}			30		μA
PG Output Pull-up Resistor	$R_{O(PULL-UP)}$			5		K Ω
PG Output Load Resistor	$R_{O(LOAD)}$		0.5	1	2	K Ω
PG Delay Time	t_{DLY}	$C=2.2\mu F$	100	250	500	ms
TOTAL DEVICE						
Standby Supply Current	I_{CC}			10	20	mA
OSCILLATION SECTION						
Oscillation Frequency	F_{OSC}	$C_T=2200P$	50		70	KHz
Frequency Change With TEMP.	$F_{OSC/T}$	$C_T=2200P$		2		%

■ FUNCTION DESCRIPTION

(1) REMOTE ON/OFF

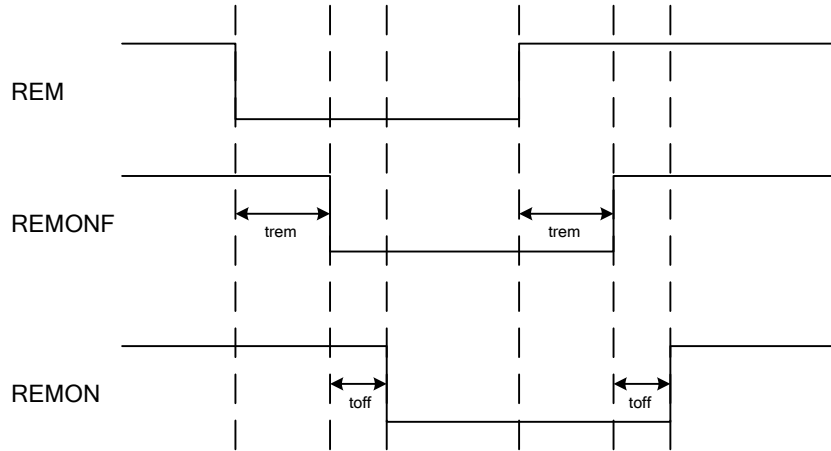

(2) Under Voltage Protection Delay Time

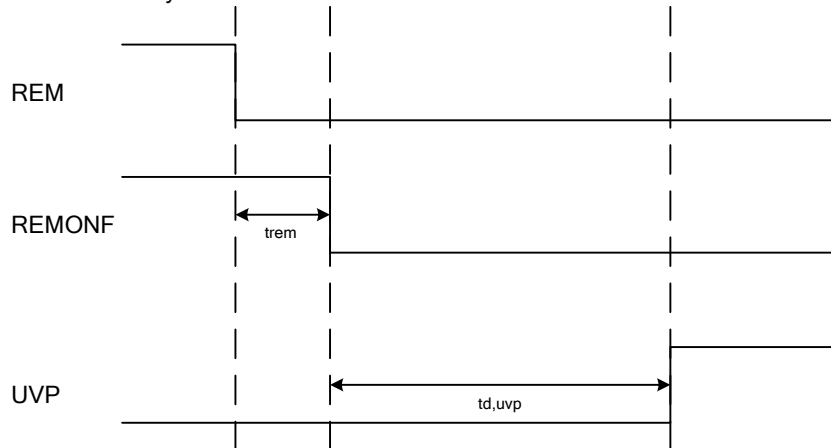

(3) Pulse Width Modulation

The output pulse width modulation is generated by comparison of the saw-tooth waveform from the capacitor C_T to the feedback of the voltage. Therefore, an increase in feedback control signal amplitude causes a linear decrease of the output pulse width.

(4) Protection Control of the Soft-Start

The soft-start function is to reduce the large current surge during power-up or preventing the output voltages ($V_{33}/V_5/V_{12}$) reaches the Over Voltage Protection level.

(5) The function of PT

This signal is prepared for extra Over Voltage Protection Input ($V_{PT} > 1.25V$) or another Disable Under Voltage Protection function ($V_{PT} < 0.62V$).

■ APPLICATION CIRCUIT

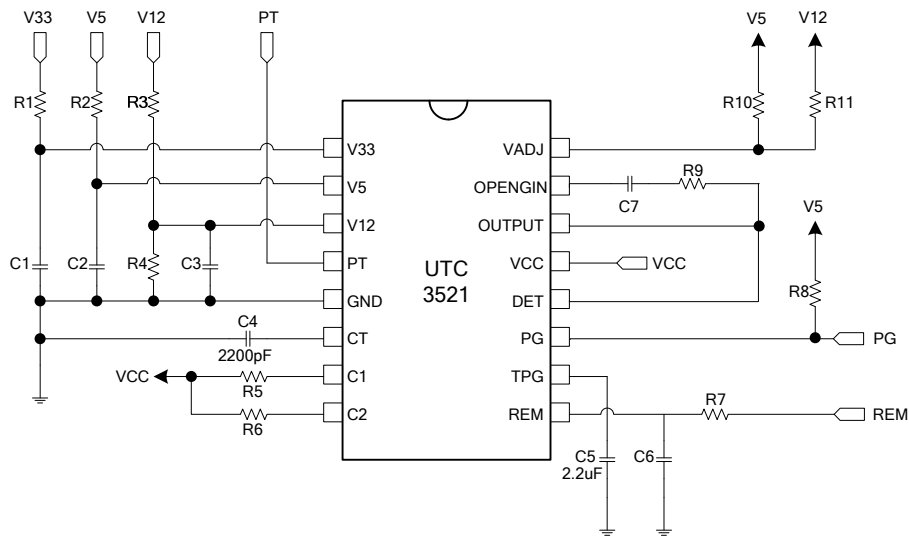

UTC assumes no responsibility for equipment failures that result from using products at values that exceed, even momentarily, rated values (such as maximum ratings, operating condition ranges, or other parameters) listed in products specifications of any and all UTC products described or contained herein. UTC products are not designed for use in life support appliances, devices or systems where malfunction of these products can be reasonably expected to result in personal injury. Reproduction in whole or in part is prohibited without the prior written consent of the copyright owner. The information presented in this document does not form part of any quotation or contract, is believed to be accurate and reliable and may be changed without notice.