



3N60

Power MOSFET

3A, 600V N-CHANNEL POWER MOSFET

DESCRIPTION

The UTC **3N60** is a high voltage and high current power MOSFET, designed to have better characteristics, such as fast switching time, low gate charge, low on-state resistance and have a high rugged avalanche characteristics. This power MOSFET is usually used at high speed switching applications in power supplies, PWM motor controls, high efficient DC to DC converters and bridge circuits.

FEATURES

- * $V_{DS} = 600V$, $I_D = 3A$
- * $R_{DS(ON)} < 3.6\Omega$ @ $V_{GS} = 10V$
- * Ultra low gate charge (typical 18 nC)
- * Low reverse transfer capacitance ($C_{RSS} =$ typical 5.5 pF)
- * Fast switching capability
- * Avalanche energy specified
- * Improved dv/dt capability, high ruggedness

SYMBOL

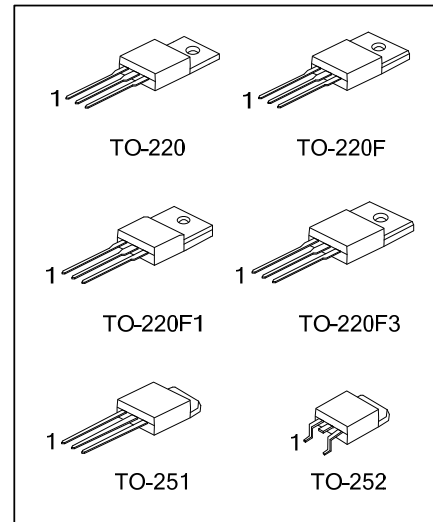
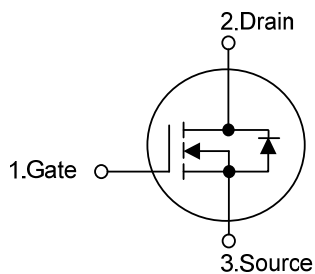

FLYING 汎翔國際有限公司
www.flying1688.com

ORDERING INFORMATION

Ordering Number		Package	Pin Assignment			Packing
Lead Free	Halogen Free		1	2	3	
3N60L-TA3-T	3N60G-TA3-T	TO-220	G	D	S	Tube
3N60L-TF1-T	3N60G-TF1-T	TO-220F1	G	D	S	Tube
3N60L-TF3-T	3N60G-TF3-T	TO-220F	G	D	S	Tube
3N60L-TF3T-T	3N60G-TF3T-T	TO-220F3	G	D	S	Tube
3N60L-TM3-T	3N60G-TM3-T	TO-251	G	D	S	Tube
3N60L-TN3-R	3N60G-TN3-R	TO-252	G	D	S	Tape Reel

Note: Pin Assignment: G: Gate D: Drain S: Source

<p>3N60L-TA3-T</p> <p>(1) Packing Type</p> <p>(2) Package Type</p> <p>(3) Lead Free</p>	<p>(1) T: Tube, R: Tape Reel</p> <p>(2) TA3: TO-220, TF1: TO-220F1, TF3: TO-22F, TF3T: TO-220F3, TM3: TO-251, TN3: TO-252</p> <p>(3) L: Lead Free, G: Halogen Free</p>
-----------------------------------------------------------------------------------------	------------------------------------------------------------------------------------------------------------------------------------------------------------------------

MARKING INFORMATION

PACKAGE	MARKING
TO-220 TO-220F TO-220F1 TO-220F3 TO-251 TO-252	<p>UTC</p> <p>3N60</p> <p>Lot Code → Data Code</p> <p>L: Lead Free G: Halogen Free</p> <p>1</p>

汎翔國際有限公司
 www.flying1688.com

■ ABSOLUTE MAXIMUM RATINGS ($T_C = 25^\circ\text{C}$, unless otherwise specified)

PARAMETER		SYMBOL	RATINGS	UNIT
Drain-Source Voltage		V_{DSS}	600	V
Gate-Source Voltage		V_{GSS}	± 30	V
Avalanche Current (Note 2)		I_{AR}	3.0	A
Continuous Drain Current		I_D	3.0	A
Pulsed Drain Current (Note 2)		I_{DM}	12	A
Avalanche Energy	Single Pulsed (Note 3)	E_{AS}	200	mJ
	Repetitive (Note 2)	E_{AR}	7.5	mJ
Peak Diode Recovery dv/dt (Note 4)		dv/dt	4.5	V/ns
Power Dissipation	TO-220	P_D	75	W
	TO-220F/TO-220F1		34	
	TO-220F3		50	
	TO-251/TO-252			
Junction Temperature		T_J	+150	$^\circ\text{C}$
Operating Temperature		T_{OPR}	-55 ~ +150	$^\circ\text{C}$
Storage Temperature		T_{STG}	-55 ~ +150	$^\circ\text{C}$

Notes: 1. Absolute maximum ratings are those values beyond which the device could be permanently damaged.

Absolute maximum ratings are stress ratings only and functional device operation is not implied.

2. Repetitive Rating : Pulse width limited by T_J .

3. $L=44.4\text{mH}$, $I_{AS}=3\text{A}$, $V_{DD}=50\text{V}$, $R_G=25\ \Omega$, Starting $T_J = 25^\circ\text{C}$

4. $I_{SD}\leq 3.0\text{A}$, $di/dt\leq 200\text{A}/\mu\text{s}$, $V_{DD}\leq BV_{DSS}$, Starting $T_J = 25^\circ\text{C}$

■ THERMAL DATA

PARAMETER		SYMBOL	RATING	UNIT
Junction to Ambient	TO-220	θ_{JA}	62.5	$^\circ\text{C}/\text{W}$
	TO-220F/TO-220F1		62.5	
	TO-220F3		110	
	TO-251/TO-252			
Junction to Case	TO-220	θ_{JC}	1.67	$^\circ\text{C}/\text{W}$
	TO-220F/TO-220F1		3.68	
	TO-220F3			
	TO-251/TO-252		2.5	

■ ELECTRICAL CHARACTERISTICS ($T_C=25^\circ\text{C}$, unless otherwise specified)

PARAMETER	SYMBOL	TEST CONDITIONS	MIN	TYP	MAX	UNIT
OFF CHARACTERISTICS						
Drain-Source Breakdown Voltage	BV_{DSS}	$V_{GS}=0\text{ V}, I_D=250\ \mu\text{A}$	600			V
Drain-Source Leakage Current	I_{DSS}	$V_{DS}=600\text{ V}, V_{GS}=0\text{ V}$			10	μA
Gate-Source Leakage Current	Forward	I_{GSS}			100	nA
	Reverse				$V_{GS}=-30\text{ V}, V_{DS}=0\text{ V}$	-100
Breakdown Voltage Temperature Coefficient	$\Delta BV_{DSS}/\Delta T_J$	$I_D=250\ \mu\text{A}$, Referenced to 25°C		0.6		$^\circ\text{V}/^\circ\text{C}$
ON CHARACTERISTICS						
Gate Threshold Voltage	$V_{GS(TH)}$	$V_{DS}=V_{GS}, I_D=250\ \mu\text{A}$	2.0		4.0	V
Static Drain-Source On-State Resistance	$R_{DS(ON)}$	$V_{GS}=10\text{ V}, I_D=1.5\text{ A}$		2.8	3.6	Ω
DYNAMIC CHARACTERISTICS						
Input Capacitance	C_{ISS}	$V_{DS}=25\text{ V}, V_{GS}=0\text{ V}, f=1\text{ MHz}$		350	450	pF
Output Capacitance	C_{OSS}			50	65	pF
Reverse Transfer Capacitance	C_{RSS}			5.5	7.5	pF
SWITCHING CHARACTERISTICS						
Turn-On Delay Time	$t_{D(ON)}$	$V_{DD}=30\text{ V}, I_D=0.5\text{ A}, R_G=25\ \Omega$ (Note 1, 2)		35	50	ns
Turn-On Rise Time	t_R			60	70	ns
Turn-Off Delay Time	$t_{D(OFF)}$			100	150	ns
Turn-Off Fall Time	t_F			65	75	ns
Total Gate Charge	Q_G	$V_{DS}=50\text{ V}, I_D=1.3\text{ A}, I_G=100\ \mu\text{A}$ $V_{GS}=10\text{ V}$ (Note 1, 2)		18.5	23	nC
Gate-Source Charge	Q_{GS}			5.2		nC
Gate-Drain Charge	Q_{GD}			4.9		nC
SOURCE- DRAIN DIODE RATINGS AND CHARACTERISTICS						
Drain-Source Diode Forward Voltage	V_{SD}	$V_{GS}=0\text{ V}, I_S=3.0\text{ A}$			1.4	V
Maximum Continuous Drain-Source Diode Forward Current	I_S				3.0	A
Maximum Pulsed Drain-Source Diode Forward Current	I_{SM}				12	A
Reverse Recovery Time	t_{RR}	$V_{GS}=0\text{ V}, I_S=3.0\text{ A},$		210		ns
Reverse Recovery Charge	Q_{RR}	$di/dt = 100\text{ A}/\mu\text{s}$ (Note 1)		1.2		μC

Notes: 1. Pulse Test: Pulse width $\leq 300\ \mu\text{s}$, Duty cycle $\leq 2\%$.

2. Essentially independent of operating temperature.

TEST CIRCUITS AND WAVEFORMS

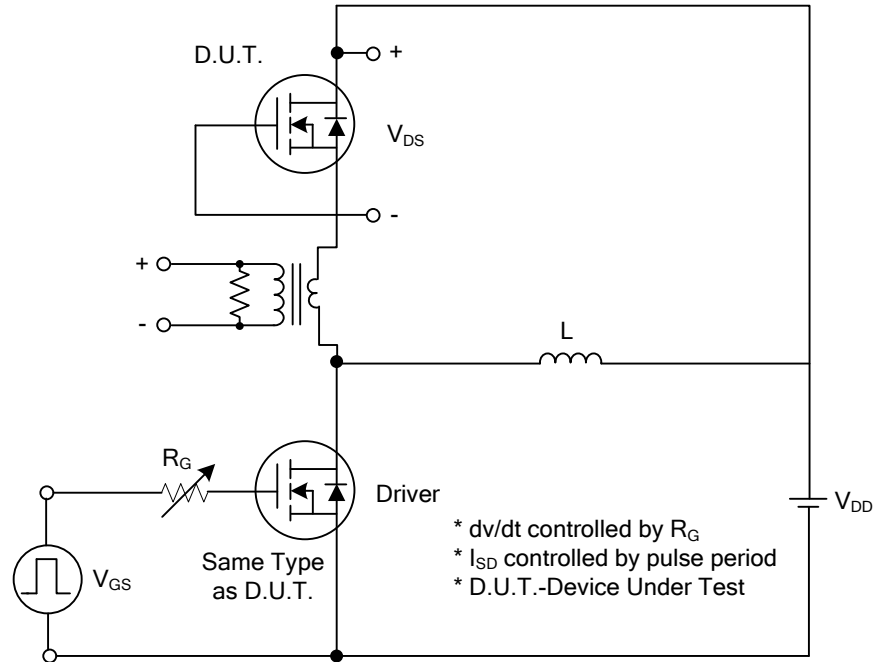

Peak Diode Recovery dv/dt Test Circuit

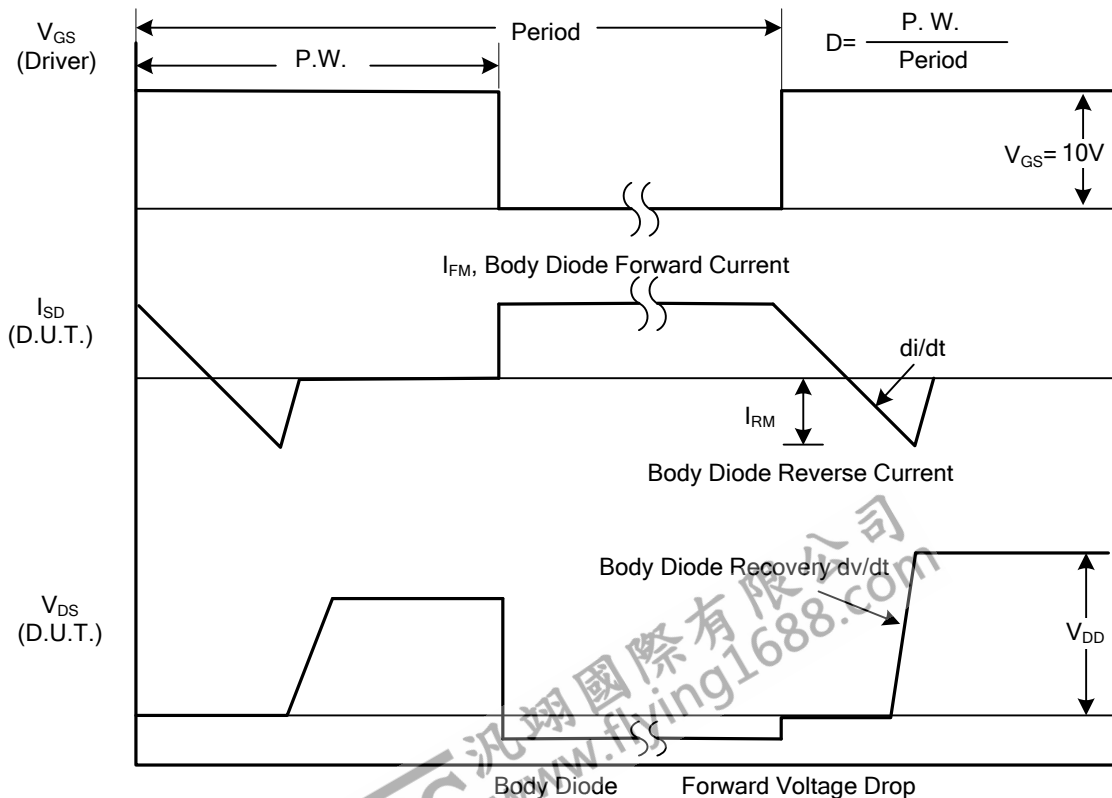

Peak Diode Recovery dv/dt Waveforms

■ TEST CIRCUITS AND WAVEFORMS (Cont.)

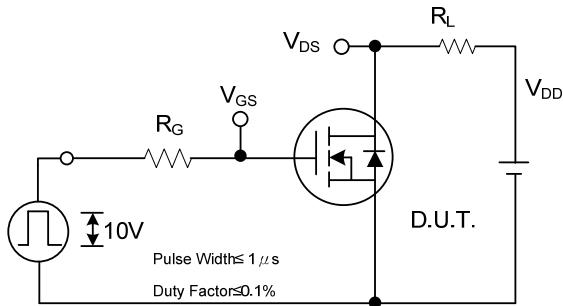

Switching Test Circuit

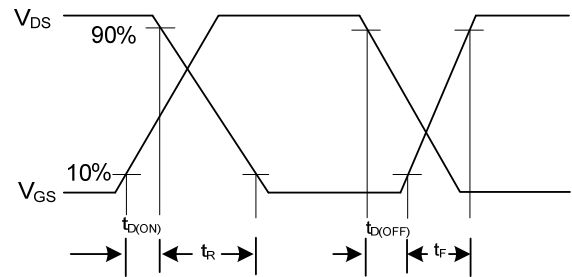

Switching Waveforms

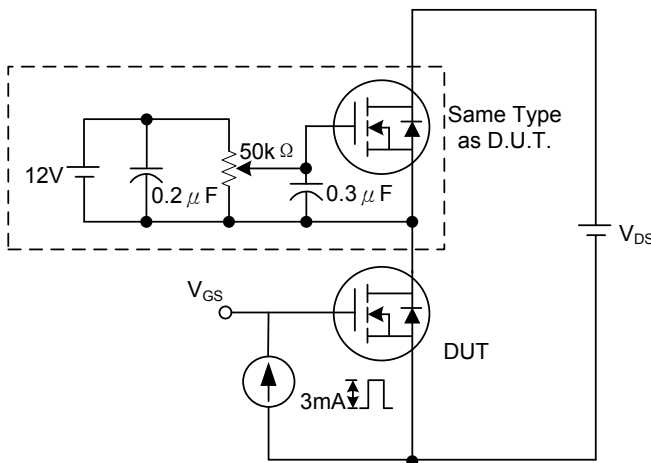

Gate Charge Test Circuit

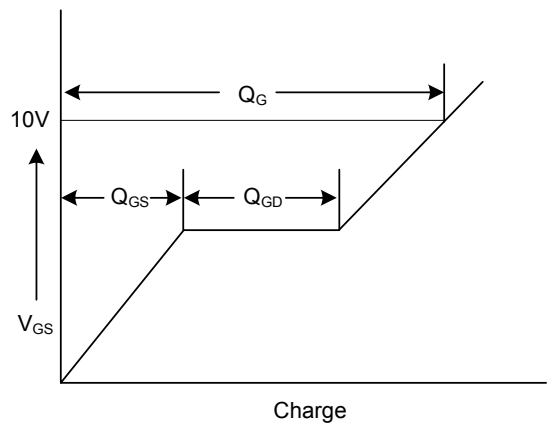

Gate Charge Waveform

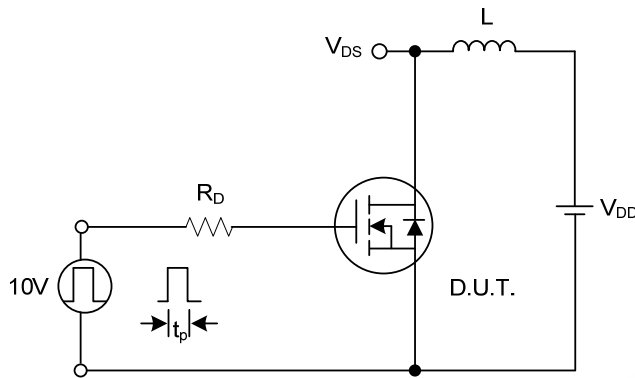

Unclamped Inductive Switching Test Circuit

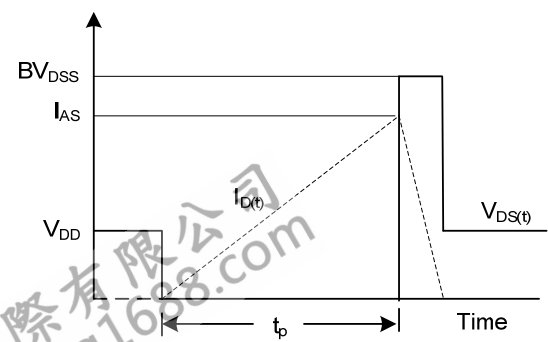

Unclamped Inductive Switching Waveforms

TYPICAL CHARACTERISTICS

On-State Characteristics

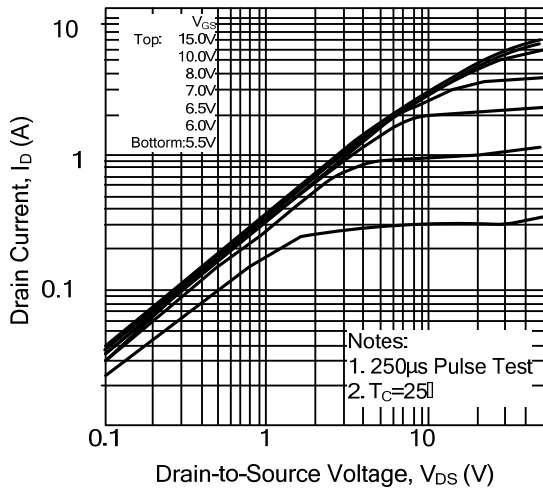

Transfer Characteristics

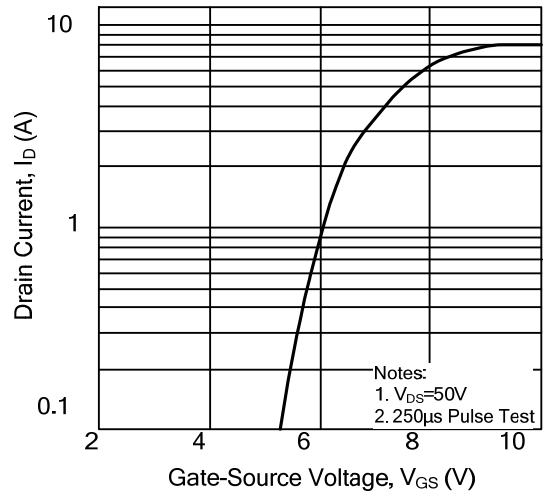

On-Resistance Variation vs. Drain Current and Gate Voltage

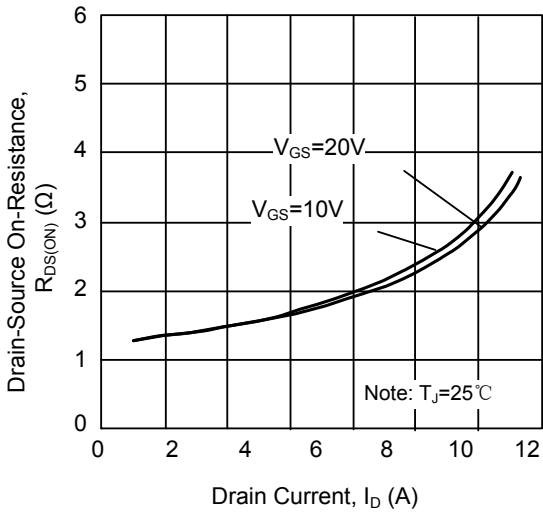

On State Current vs. Allowable Case Temperature

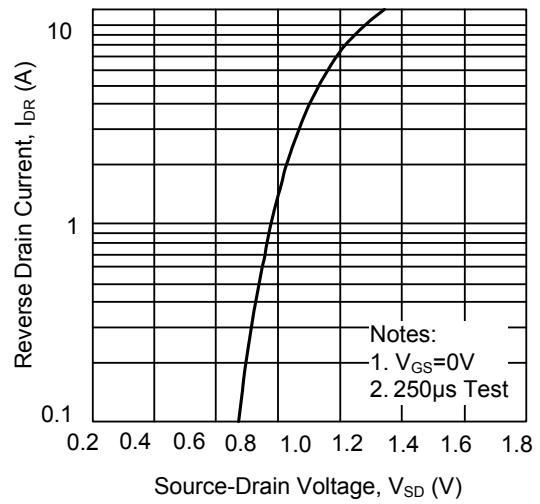

Capacitance Characteristics (Non-Repetitive)

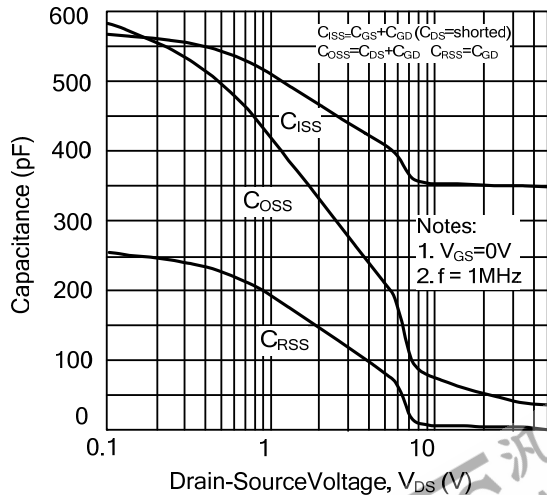

Gate Charge Characteristics

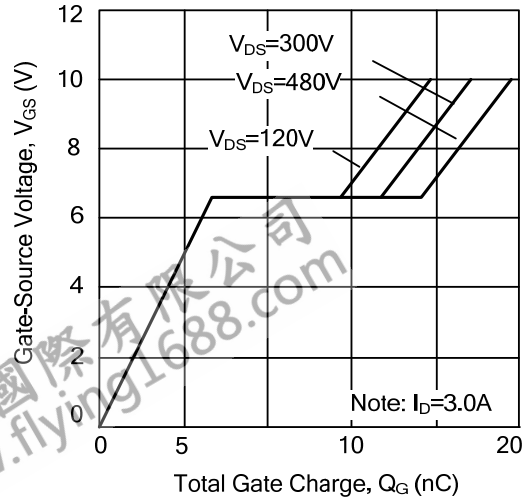

TYPICAL CHARACTERISTICS(Cont.)

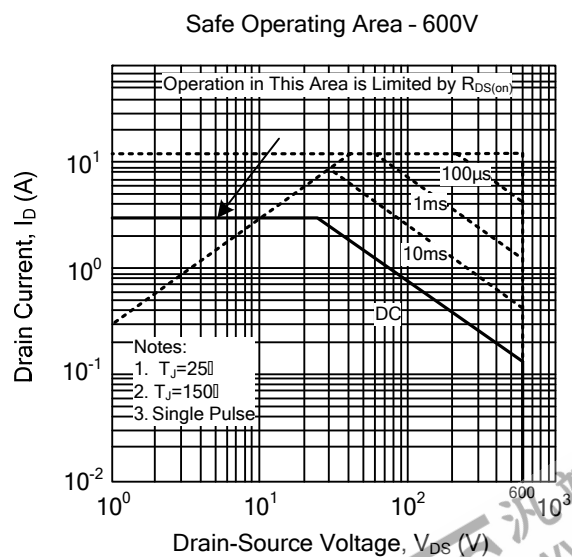
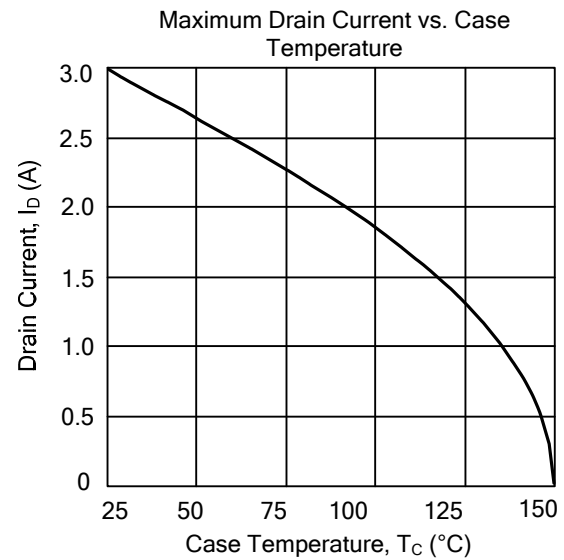
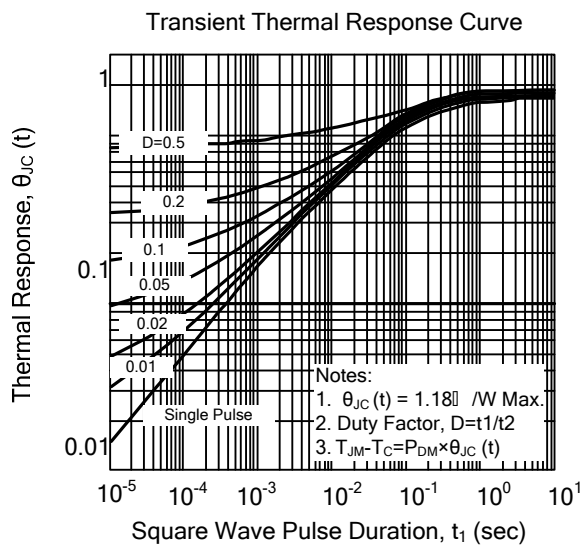
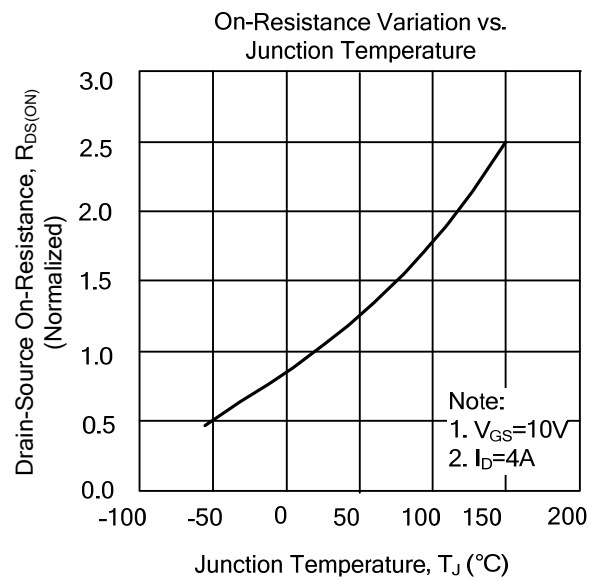
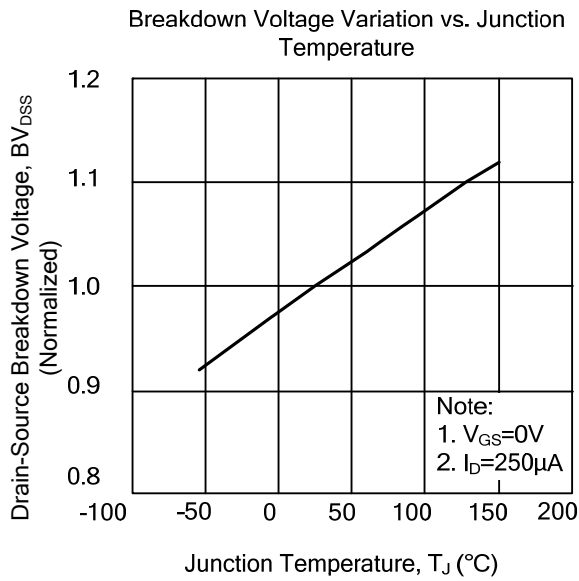

UTC assumes no responsibility for equipment failures that result from using products at values that exceed, even momentarily, rated values (such as maximum ratings, operating condition ranges, or other parameters) listed in products specifications of any and all UTC products described or contained herein. UTC products are not designed for use in life support appliances, devices or systems where malfunction of these products can be reasonably expected to result in personal injury. Reproduction in whole or in part is prohibited without the prior written consent of the copyright owner. The information presented in this document does not form part of any quotation or contract, is believed to be accurate and reliable and may be changed without notice.