



3N65K-MK4

Preliminary

Power MOSFET

3A, 650V N-CHANNEL POWER MOSFET

DESCRIPTION

The UTC 3N65K-MK4 is a high voltage and high current power MOSFET designed to have better characteristics, such as fast switching time, low gate charge, low on-state resistance and high rugged avalanche characteristics. This power MOSFET is usually used in high speed switching applications at power supplies, PWM motor controls, high efficient DC to DC converters and bridge circuits.

FEATURES

- * $R_{DS(ON)} < 3.5\Omega @ V_{GS} = 10V, I_D = 1.5A$
- * Fast switching capability
- * Avalanche energy specified
- * Improved dv/dt capability, high ruggedness

SYMBOL

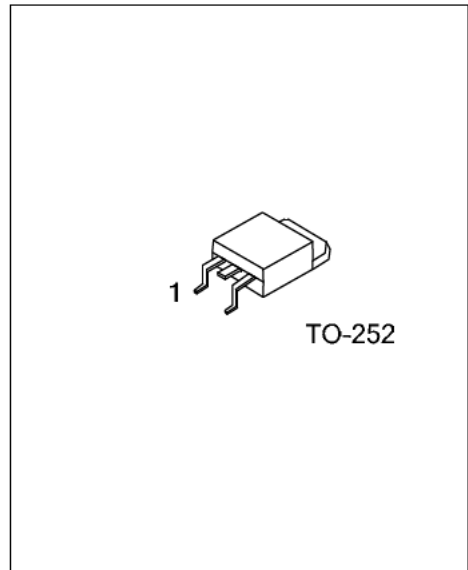
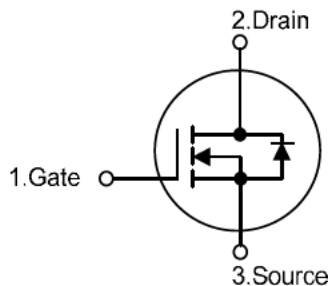

ORDERING INFORMATION

Ordering Number		Package	Pin Assignment			Packing
Lead Free	Halogen Free		1	2	3	
3N65KL-TN3-R	3N65KG-TN3-R	TO-252	G	D	S	Tape Reel

Note: Pin Assignment: G: Gate D: Drain S: Source

<p>3N65KL-TN3-R</p>	<p>(1) R: Tape Reel (2) TN3: TO-252 (3) L: Lead Free, G: Halogen Free</p>
---------------------	---

MARKING

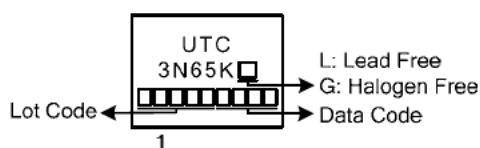

■ **ABSOLUTE MAXIMUM RATINGS** ($T_C = 25^\circ\text{C}$, unless otherwise specified)

PARAMETER	SYMBOL	RATINGS	UNIT
Drain-Source Voltage	V_{DSS}	650	V
Gate-Source Voltage	V_{GSS}	± 30	V
Avalanche Current (Note 2)	I_{AR}	3.0	A
Continuous Drain Current	I_D	3.0	A
Pulsed Drain Current (Note 2)	I_{DM}	12	A
Avalanche Energy	Single Pulsed (Note 3)	E_{AS}	130
	Repetitive (Note 2)	E_{AR}	7.5
Peak Diode Recovery dv/dt (Note 4)	dv/dt	4.5	V/ns
Power Dissipation	P_D	50	W
Derate above 25°C		0.4	W/ $^\circ\text{C}$
Junction Temperature	T_J	+150	$^\circ\text{C}$
Operating Temperature	T_{OPR}	-55 ~ +150	$^\circ\text{C}$
Storage Temperature	T_{STG}	-55 ~ +150	$^\circ\text{C}$

Notes: 1. Absolute maximum ratings are those values beyond which the device could be permanently damaged.

Absolute maximum ratings are stress ratings only and functional device operation is not implied.

2. Repetitive Rating : Pulse width limited by T_J .

3. $L=28\text{mH}$, $I_{AS}=3\text{A}$, $V_{DD}=50\text{V}$, $R_G=25\ \Omega$, Starting $T_J = 25^\circ\text{C}$

4. $I_{SD} \leq 3.0\text{A}$, $di/dt \leq 200\text{A}/\mu\text{s}$, $V_{DD} \leq BV_{DSS}$, Starting $T_J = 25^\circ\text{C}$

■ **THERMAL DATA**

PARAMETER	SYMBOL	RATINGS	UNIT
Junction to Ambient	θ_{JA}	110	$^\circ\text{C}/\text{W}$
Junction to Case	θ_{JC}	2.5	$^\circ\text{C}/\text{W}$

■ **ELECTRICAL CHARACTERISTICS** ($T_C = 25^\circ\text{C}$, unless otherwise specified)

PARAMETER	SYMBOL	TEST CONDITIONS	MIN	TYP	MAX	UNIT
OFF CHARACTERISTICS						
Drain-Source Breakdown Voltage	BV_{DSS}	$V_{GS} = 0\text{ V}, I_D = 250\ \mu\text{A}$	650			V
Drain-Source Leakage Current	I_{DSS}	$V_{DS} = 650\text{ V}, V_{GS} = 0\text{ V}$			10	μA
Gate-Source Leakage Current	Forward	I_{GSS}			100	nA
	Reverse				-100	nA
Breakdown Voltage Temperature Coefficient	$\Delta BV_{DSS}/\Delta T_J$	$I_D = 250\ \mu\text{A}$, Referenced to 25°C		0.6		$\text{V}/^\circ\text{C}$
ON CHARACTERISTICS						
Gate Threshold Voltage	$V_{GS(TH)}$	$V_{DS} = V_{GS}, I_D = 250\ \mu\text{A}$	2.5		4.5	V
Static Drain-Source On-State Resistance	$R_{DS(ON)}$	$V_{GS} = 10\text{ V}, I_D = 1.5\text{ A}$			3.5	Ω
DYNAMIC CHARACTERISTICS						
Input Capacitance	C_{ISS}	$V_{DS} = 25\text{ V}, V_{GS} = 0\text{ V},$ $f = 1\text{ MHz}$		385		pF
Output Capacitance	C_{OSS}			60		pF
Reverse Transfer Capacitance	C_{RSS}			5		pF
SWITCHING CHARACTERISTICS						
Turn-On Delay Time	$t_{D(ON)}$	$V_{DD} = 30\text{ V}, I_D = 0.5\text{ A},$ $R_G = 25\ \Omega$ (Note 1, 2)		43		ns
Turn-On Rise Time	t_R			20		ns
Turn-Off Delay Time	$t_{D(OFF)}$			90		ns
Turn-Off Fall Time	t_F			18		ns
Total Gate Charge	Q_G	$V_{DS} = 50\text{ V}, I_D = 1.3\text{ A},$ $V_{GS} = 10\text{ V}$ (Note 1, 2)		14		nC
Gate-Source Charge	Q_{GS}			5.8		nC
Gate-Drain Charge	Q_{DD}			1.7		nC
SOURCE- DRAIN DIODE RATINGS AND CHARACTERISTICS						
Drain-Source Diode Forward Voltage	V_{SD}	$V_{GS} = 0\text{ V}, I_S = 3.0\text{ A}$			1.4	V
Maximum Continuous Drain-Source Diode Forward Current	I_S				3.0	A
Maximum Pulsed Drain-Source Diode Forward Current	I_{SM}				12	A

Notes: 1. Pulse Test: Pulse width $\leq 300\ \mu\text{s}$, Duty cycle $\leq 2\%$

2. Essentially independent of operating temperature

■ TEST CIRCUITS AND WAVEFORMS

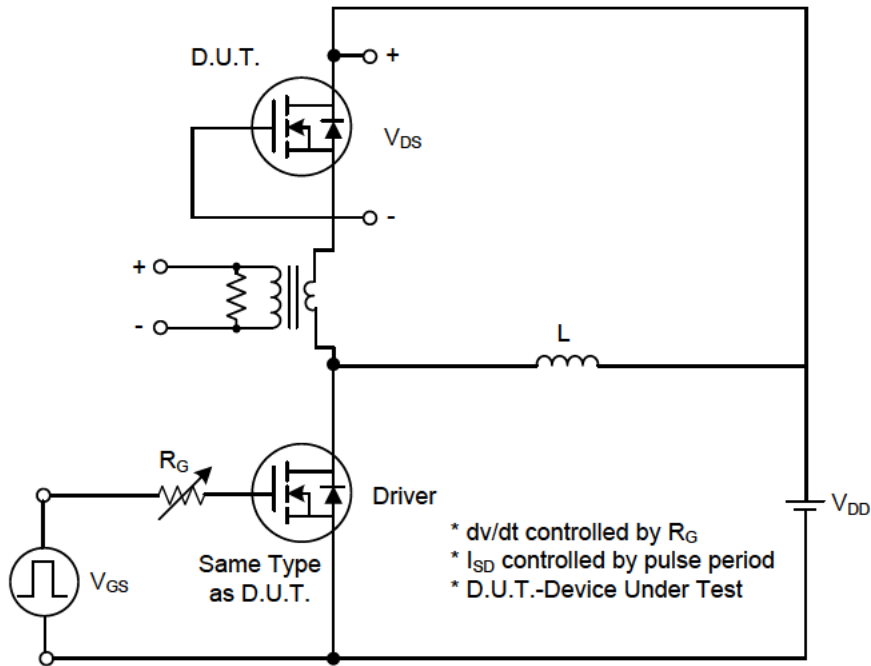

Peak Diode Recovery dv/dt Test Circuit

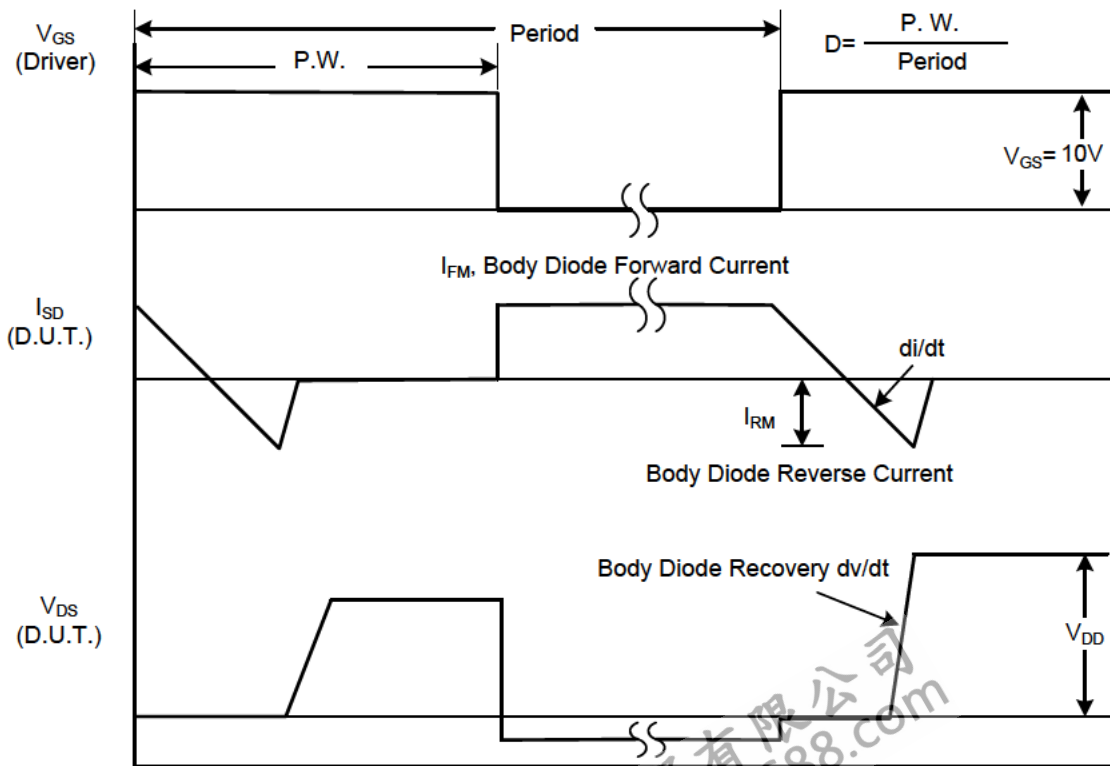

Body Diode Forward Voltage Drop
Peak Diode Recovery dv/dt Waveforms

■ TEST CIRCUITS AND WAVEFORMS (Cont.)

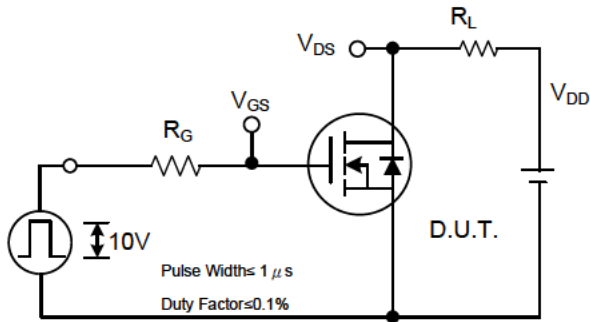

Switching Test Circuit

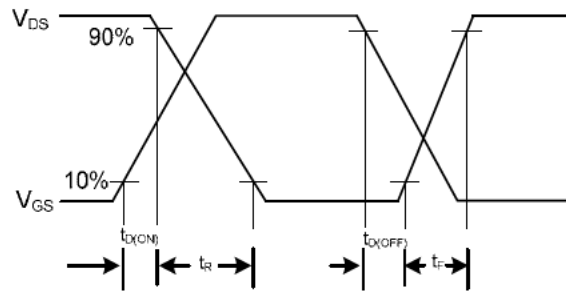

Switching Waveforms

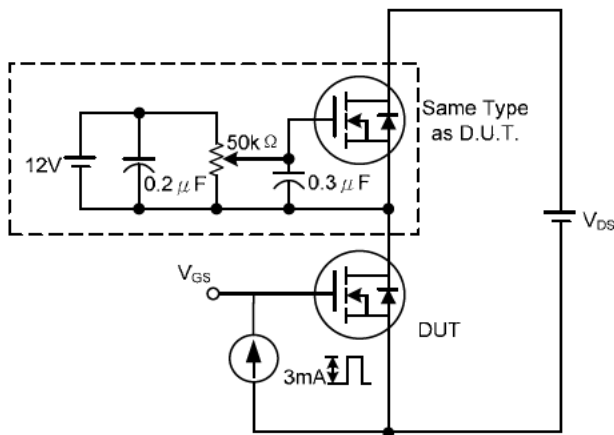

Gate Charge Test Circuit

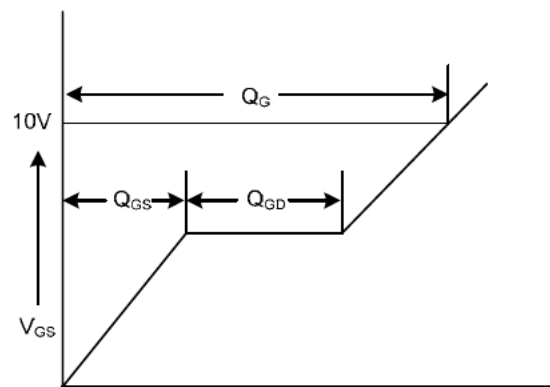

Gate Charge Waveform

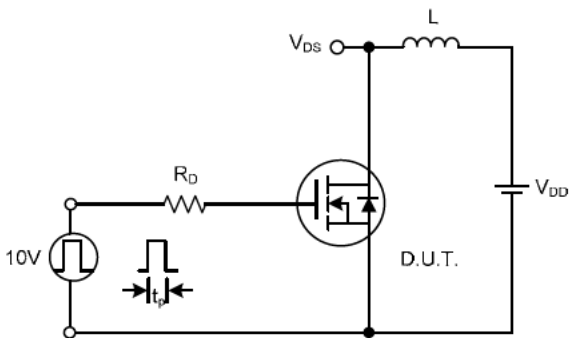

Unclamped Inductive Switching Test Circuit

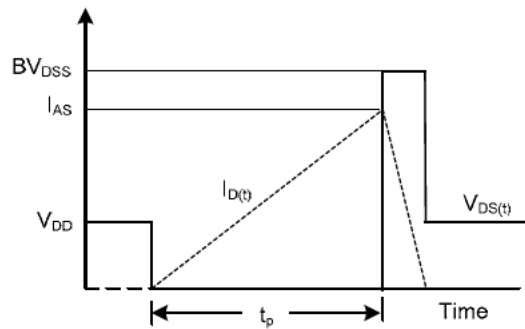

Unclamped Inductive Switching Waveforms

UTC assumes no responsibility for equipment failures that result from using products at values that exceed, even momentarily, rated values (such as maximum ratings, operating condition ranges, or other parameters) listed in products specifications of any and all UTC products described or contained herein. UTC products are not designed for use in life support appliances, devices or systems where malfunction of these products can be reasonably expected to result in personal injury. Reproduction in whole or in part is prohibited without the prior written consent of the copyright owner. The information presented in this document does not form part of any quotation or contract, is believed to be accurate and reliable and may be changed without notice.