



4N60-S

Power MOSFET

4A, 600V N-CHANNEL POWER MOSFET

DESCRIPTION

The UTC **4N60-S** is a high voltage power MOSFET and is designed to have better characteristics, such as fast switching time, low gate charge, low on-state resistance and have a high rugged avalanche characteristics. This power MOSFET is usually used at high speed switching applications in power supplies, PWM motor controls, high efficient DC to DC converters and bridge circuits.

FEATURES

- * $R_{DS(ON)} < 2.5\Omega$ @ $V_{GS}=10V$, $I_D=2.2A$
- * Fast Switching Capability
- * Avalanche Energy Specified
- * Improved dv/dt Capability, high RuggednessA

SYMBOL

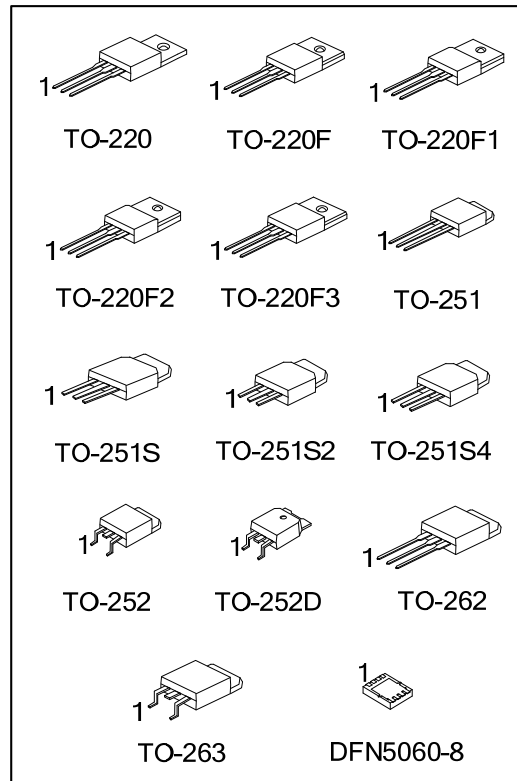
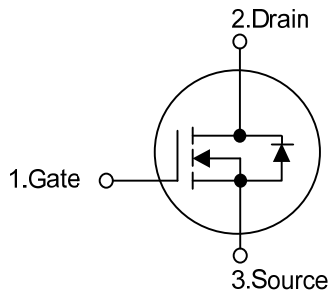

ORDERING INFORMATION

Ordering Number		Package	Pin Assignment								Packing
Lead Free	Halogen Free		1	2	3	4	5	6	7	8	
4N60L-TA3-T	4N60G-TA3-T	TO-220	G	D	S	-	-	-	-	-	Tube
4N60L-TF1-T	4N60G-TF1-T	TO-220F1	G	D	S	-	-	-	-	-	Tube
4N60L-TF2-T	4N60G-TF2-T	TO-220F2	G	D	S	-	-	-	-	-	Tube
4N60L-TF3-T	4N60G-TF3-T	TO-220F	G	D	S	-	-	-	-	-	Tube
4N60L-TF3T-T	4N60G-TF3T-T	TO-220F3	G	D	S	-	-	-	-	-	Tube
4N60L-TM3-T	4N60G-TM3-T	TO-251	G	D	S	-	-	-	-	-	Tube
4N60L-TMS-T	4N60G-TMS-T	TO-251S	G	D	S	-	-	-	-	-	Tube
4N60L-TMS2-T	4N60G-TMS2-T	TO-251S2	G	D	S	-	-	-	-	-	Tube
4N60L-TMS4-T	4N60G-TMS4-T	TO-251S4	G	D	S	-	-	-	-	-	Tube
4N60L-TN3-R	4N60G-TN3-R	TO-252	G	D	S	-	-	-	-	-	Tape Reel
4N60L-TND-R	4N60G-TND-R	TO-252D	G	D	S	-	-	-	-	-	Tape Reel
4N60L-T2Q-T	4N60G-T2Q-T	TO-262	G	D	S	-	-	-	-	-	Tube
4N60L-TQ2-R	4N60G-TQ2-R	TO-263	G	D	S	-	-	-	-	-	Tape Reel
4N60L-TQ2-T	4N60G-TQ2-T	TO-263	G	D	S	-	-	-	-	-	Tube
4N60L-K08-5060-R	4N60G-K08-5060-R	DFN-8(5x6)	S	S	S	G	D	D	D	D	Tape Reel

Note: Pin Assignment: G: Gate D: Drain S: Source

4N60G-TA3-T

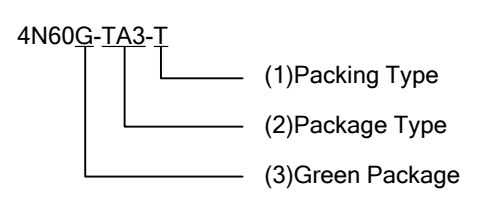

(1) Packing Type
(2) Package Type
(3) Green Package

(1) T: Tube, R: Tape Reel
 (2) TA3: TO-220, TF1: TO-220F1, TF2: TO-220F2
 TF3: TO-220F, TF3T: TO-220F3, TM3: TO-251,
 TMS: TO-251S, TMS2: TO-251S2, TN3: TO-252,
 TMS4: TO-251S4, TND: TO-252D, T2Q: TO-262,
 TQ2: TO-263, K08-5060: DFN5060-8
 (3) G: Halogen Free and Lead Free, L: Lead Free

MARKING

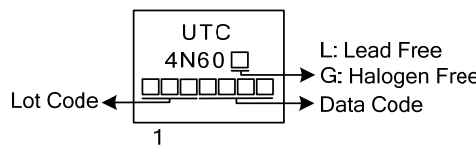
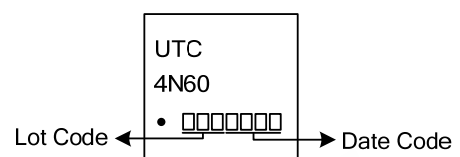
PACKAGE	MARKING
TO-220 TO-220F TO-220F1 TO-220F2 TO-220F3 TO-251 TO-251S TO-251S2 TO-251S4 TO-252 TO-252D TO-262 TO-263	 <p>UTC 4N60 Lot Code ← → Data Code</p> <p>L: Lead Free G: Halogen Free</p>
DFN5060-8	 <p>UTC 4N60 Lot Code ← → Date Code</p>

■ ABSOLUTE MAXIMUM RATINGS ($T_C = 25^\circ\text{C}$, unless otherwise specified)

PARAMETER	SYMBOL	RATINGS	UNIT	
Drain-Source Voltage	V_{DSS}	600	V	
Gate-Source Voltage	V_{GSS}	± 30	V	
Avalanche Current (Note 2)	I_{AR}	4.4	A	
Drain Current	Continuous	I_D	4.0	A
	Pulsed (Note 2)	I_{DM}	16	A
Avalanche Energy	Single Pulsed (Note 3)	E_{AS}	100	mJ
	Repetitive (Note 2)	E_{AR}	10.6	mJ
Peak Diode Recovery dv/dt (Note 4)	dv/dt	4.5	V/ns	
Power Dissipation	TO-220/TO-262/TO-263 TO-220F/TO-220F1 TO-220F2/TO-220F3	P_D	106	W
	TO-251/TO-251S TO-251S2/TO-251S4 TO-252/TO-252D		50	
	DFN5060-8		30	
Junction Temperature	T_J	+150	$^\circ\text{C}$	
Operating Temperature	T_{OPR}	-55 ~ +150	$^\circ\text{C}$	
Storage Temperature	T_{STG}	-55 ~ +150	$^\circ\text{C}$	

Notes: 1. Absolute maximum ratings are those values beyond which the device could be permanently damaged.

Absolute maximum ratings are stress ratings only and functional device operation is not implied.

2. Repetitive Rating : Pulse width limited by maximum junction temperature

3. $L = 30\text{mH}$, $I_{AS} = 2.6\text{A}$, $V_{DD} = 50\text{V}$, $R_G = 25\ \Omega$, Starting $T_J = 25^\circ\text{C}$

4. $I_{SD} \leq 4.4\text{A}$, $di/dt \leq 200\text{A}/\mu\text{s}$, $V_{DD} \leq BV_{DSS}$, Starting $T_J = 25^\circ\text{C}$

■ THERMAL DATA

PARAMETER	PACKAGE	SYMBOL	RATINGS	UNIT
Junction to Ambient	TO-220/TO-262/TO-263 TO-220F/TO-220F1 TO-220F2/TO-220F3	θ_{JA}	62.5	$^\circ\text{C}/\text{W}$
	TO-251/TO-251S TO-251S2/TO-251S4 TO-252/TO-252D		110	
	DFN5060-8		75 (Note)	
Junction to Case	TO-220/TO-262/TO-263	θ_{JC}	1.18	$^\circ\text{C}/\text{W}$
	TO-220F/TO-220F1 TO-220F3		3.47	
	TO-220F2		3.28	
	TO-251/TO-251S TO-251S2/TO-251S4 TO-252/TO-252D		2.5	
	DFN5060-8		4.17 (Note)	

Note: Note: The data tested by surface mounted on a 1 inch² FR-4 board with 2OZ copper.

■ ELECTRICAL CHARACTERISTICS (T_C=25°C, unless otherwise specified)

PARAMETER	SYMBOL	TEST CONDITIONS	MIN	TYP	MAX	UNIT	
OFF CHARACTERISTICS							
Drain-Source Breakdown Voltage	BV _{DSS}	V _{GS} = 0V, I _D = 250μA	600			V	
Drain-Source Leakage Current	I _{DSS}	V _{DS} = 600V, V _{GS} = 0V			10	μA	
Gate-Source Leakage Current	Forward	I _{GSS}			100	nA	
	Reverse				-100	nA	
Breakdown Voltage Temperature Coefficient	ΔBV _{DSS} /ΔT _J	I _D =250μA, Referenced to 25°C		0.6		V/°C	
ON CHARACTERISTICS							
Gate Threshold Voltage	V _{GS(TH)}	V _{DS} = V _{GS} , I _D = 250μA	3.0		5.0	V	
Static Drain-Source On-State Resistance	R _{DS(ON)}	V _{GS} = 10 V, I _D = 2.2A		2.2	2.5	Ω	
DYNAMIC CHARACTERISTICS							
Input Capacitance	C _{ISS}	V _{DS} = 25V, V _{GS} = 0V, f = 1MHz		440	520	pF	
Output Capacitance	C _{OSS}				45	60	pF
Reverse Transfer Capacitance	C _{RSS}				8	11	pF
SWITCHING CHARACTERISTICS							
Turn-On Delay Time	t _{D(ON)}	V _{DD} = 300V, I _D = 4.0A, R _G = 25Ω (Note 1, 2)		40	60	ns	
Turn-On Rise Time	t _R			40	60	ns	
Turn-Off Delay Time	t _{D(OFF)}			35	55	ns	
Turn-Off Fall Time	t _F			80	100	ns	
Total Gate Charge	Q _G	V _{DS} = 480V, I _D = 4.0A, V _{GS} = 10V (Note 1, 2)		35		nC	
Gate-Source Charge	Q _{GS}			5		nC	
Gate-Drain Charge	Q _{GD}			3		nC	
SOURCE- DRAIN DIODE RATINGS AND CHARACTERISTICS							
Drain-Source Diode Forward Voltage	V _{SD}	V _{GS} = 0V, I _S = 4.4A			1.4	V	
Maximum Continuous Drain-Source Diode Forward Current	I _S				4.4	A	
Maximum Pulsed Drain-Source Diode Forward Current	I _{SM}				17.6	A	
Reverse Recovery Time	t _{rr}	V _{GS} = 0 V, I _S = 4.4A, dI _F /dt = 100 A/μs (Note 1)		250		ns	
Reverse Recovery Charge	Q _{RR}			1.5		μC	

Notes: 1. Pulse Test: Pulse width ≤ 300μs, Duty cycle ≤ 2%
2. Essentially independent of operating temperature

TEST CIRCUITS AND WAVEFORMS (Cont.)

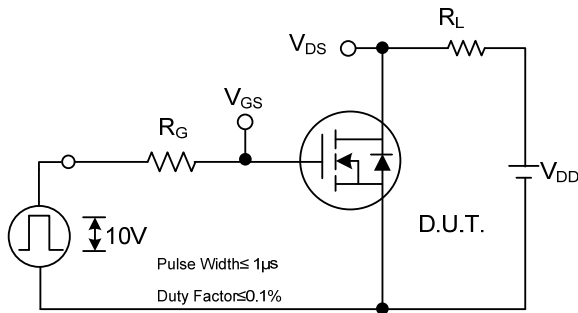

Switching Test Circuit

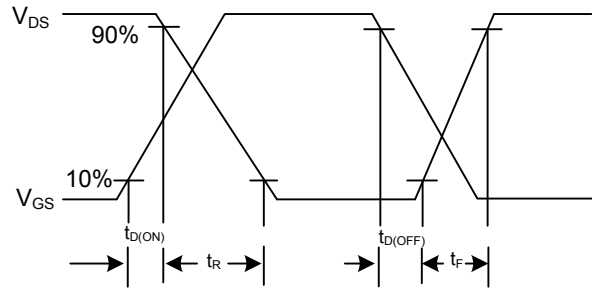

Switching Waveforms

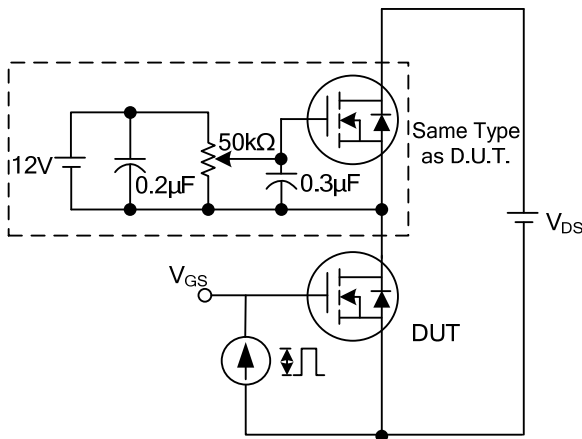

Gate Charge Test Circuit

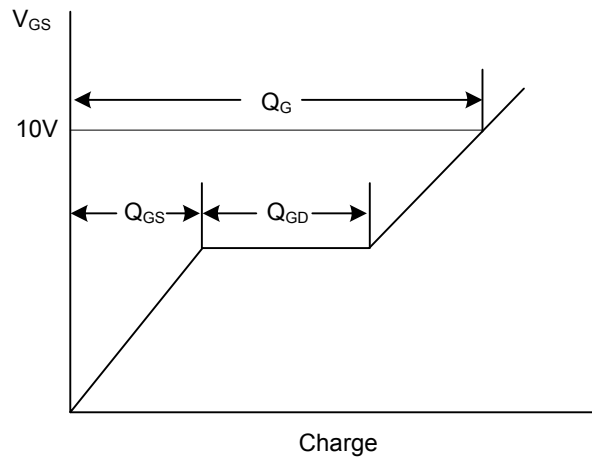

Gate Charge Waveform

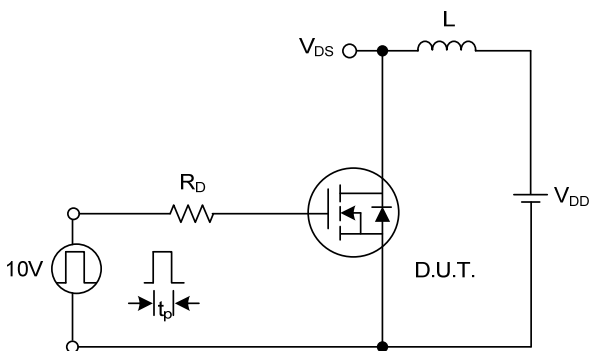

Unclamped Inductive Switching Test Circuit

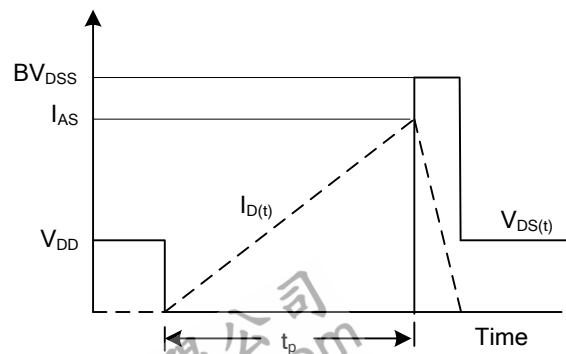

Unclamped Inductive Switching Waveforms

UTC assumes no responsibility for equipment failures that result from using products at values that exceed, even momentarily, rated values (such as maximum ratings, operating condition ranges, or other parameters) listed in products specifications of any and all UTC products described or contained herein. UTC products are not designed for use in life support appliances, devices or systems where malfunction of these products can be reasonably expected to result in personal injury. Reproduction in whole or in part is prohibited without the prior written consent of the copyright owner. The information presented in this document does not form part of any quotation or contract, is believed to be accurate and reliable and may be changed without notice.