



4N60K-MTQ

Preliminary

Power MOSFET

4.0A, 600V N-CHANNEL
POWER MOSFET

DESCRIPTION

The UTC **4N60K-MTQ** is a high voltage power MOSFET and is designed to have better characteristics, such as fast switching time, low gate charge, low on-state resistance and have a high rugged avalanche characteristics. This power MOSFET is usually used at high speed switching applications in power supplies, PWM motor controls, high efficient DC to DC converters and bridge circuits.

FEATURES

- * $R_{DS(ON)} < 2.5\Omega @ V_{GS} = 10V, I_D = 2.2A$
- * Fast Switching Capability
- * Avalanche Energy Specified
- * Improved dv/dt Capability, high Ruggedness

SYMBOL

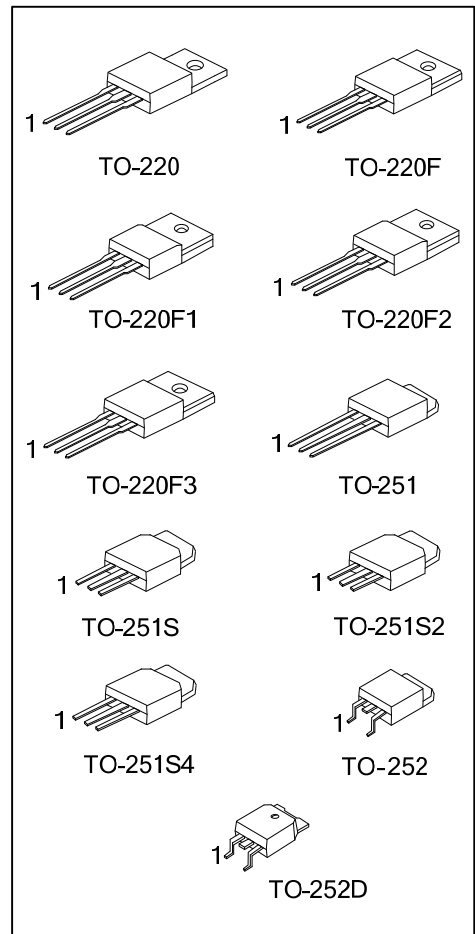
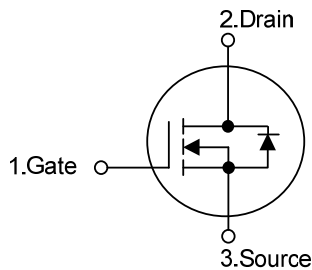

ORDERING INFORMATION

Ordering Number		Package	Pin Assignment			Packing
Lead Free	Halogen Free		1	2	3	
4N60KL-TA3-T	4N60KG-TA3-T	TO-220	G	D	S	Tube
4N60KL-TF3-T	4N60KG-TF3-T	TO-220F	G	D	S	Tube
4N60KL-TF1-T	4N60KG-TF1-T	TO-220F1	G	D	S	Tube
4N60KL-TF2-T	4N60KG-TF2-T	TO-220F2	G	D	S	Tube
4N60KL-TF3T-T	4N60KG-TF3T-T	TO-220F3	G	D	S	Tube
4N60KL-TM3-T	4N60KG-TM3-T	TO-251	G	D	S	Tube
4N60KL-TMS-T	4N60KG-TMS-T	TO-251S	G	D	S	Tube
4N60KL-TMS2-T	4N60KG-TMS2-T	TO-251S2	G	D	S	Tube
4N60KL-TMS4-T	4N60KG-TMS4-T	TO-251S4	G	D	S	Tube
4N60KL-TN3-R	4N60KG-TN3-R	TO-252	G	D	S	Tape Reel
4N60KL-TND-R	4N60KG-TND-R	TO-252D	G	D	S	Tape Reel

Note: Pin Assignment: G: Gate D: Drain S: Source

<p>4N60KL-TA3-T</p> <p>(1) Packing Type (2) Package Type (3) Green Package</p>	<p>(1) T: Tube, R: Tape Reel (2) TA3: TO-220, TF3: TO-220F, TF1: TO-220F1, TF2: TO-220F2, TF3T: TO-220F3, TM3: TO-251 TMS: TO-251S, TMS2: TO-251S2, TMS4: TO-251S4, TN3: TO-252, TND: TO-252D (3) L: Lead Free, G: Halogen Free and Lead Free</p>
--	---

MARKING

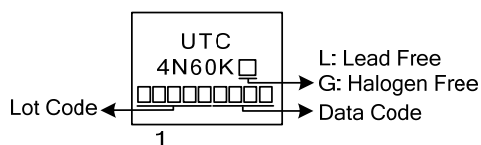

■ ABSOLUTE MAXIMUM RATINGS ($T_C = 25^\circ\text{C}$, unless otherwise specified)

PARAMETER		SYMBOL	RATINGS	UNIT
Drain-Source Voltage		V_{DSS}	600	V
Gate-Source Voltage		V_{GSS}	± 30	V
Drain Current	Continuous	I_D	4.0	A
	Pulsed (Note 2)	I_{DM}	16	A
Avalanche Energy	Single Pulsed (Note 3)	E_{AS}	133	mJ
Peak Diode Recovery dv/dt (Note 4)		dv/dt	3.74	V/ns
Power Dissipation	TO-220	P_D	106	W
	TO-220F/TO-220F1 TO-220F2/TO-220F3		36	
	TO-251/TO-251S TO-251S2/TO-251S4 TO-252/TO-252D		50	
Junction Temperature		T_J	+150	$^\circ\text{C}$
Operating Temperature		T_{OPR}	-55 ~ +150	$^\circ\text{C}$
Storage Temperature		T_{STG}	-55 ~ +150	$^\circ\text{C}$

- Notes: 1. Absolute maximum ratings are those values beyond which the device could be permanently damaged. Absolute maximum ratings are stress ratings only and functional device operation is not implied.
 2. Repetitive Rating : Pulse width limited by maximum junction temperature
 3. $L = 26\text{mH}$, $I_{AS} = 3.2\text{A}$, $V_{DD} = 50\text{V}$, $R_G = 25\ \Omega$, Starting $T_J = 25^\circ\text{C}$
 4. $I_{SD} \leq 4.0\text{A}$, $di/dt \leq 200\text{A}/\mu\text{s}$, $V_{DD} \leq BV_{DSS}$, Starting $T_J = 25^\circ\text{C}$

■ THERMAL DATA

PARAMETER		SYMBOL	RATINGS	UNIT
Junction to Ambient	TO-220/TO-220F TO-220F1/TO-220F2 TO-220F3	θ_{JA}	62.5	$^\circ\text{C}/\text{W}$
	TO-251/TO-251S TO-251S2/TO-251S4 TO-252/TO-252D		110	$^\circ\text{C}/\text{W}$
Junction to Case	TO-220	θ_{JC}	1.18	$^\circ\text{C}/\text{W}$
	TO-220F/TO-220F1 TO-220F3		3.47	$^\circ\text{C}/\text{W}$
	TO-220F2		3.4	$^\circ\text{C}/\text{W}$
	TO-251/TO-251S TO-251S2/TO-251S4 TO-252/TO-252D		2.50	$^\circ\text{C}/\text{W}$

■ ELECTRICAL CHARACTERISTICS (T_C=25°C, unless otherwise specified)

PARAMETER	SYMBOL	TEST CONDITIONS	MIN	TYP	MAX	UNIT
OFF CHARACTERISTICS						
Drain-Source Breakdown Voltage	BV _{DSS}	V _{GS} =0V, I _D =250μA	600			V
Drain-Source Leakage Current	I _{DSS}	V _{DS} =600V, V _{GS} =0V			10	μA
		V _{DS} =600V, V _{GS} =0V, T _C =125°C			10	μA
Gate-Source Leakage Current	Forward	I _{GSS}			100	nA
	Reverse					
					-100	nA
Breakdown Voltage Temperature Coefficient	ΔBV _{DSS} /ΔT _J	I _D =250μA, Referenced to 25°C		0.6		V/°C
ON CHARACTERISTICS						
Gate Threshold Voltage	V _{GS(TH)}	V _{DS} =V _{GS} , I _D =250μA	2.0		4.5	V
Static Drain-Source On-State Resistance	R _{DS(ON)}	V _{GS} =10 V, I _D =2.2A			3.5	Ω
DYNAMIC CHARACTERISTICS						
Input Capacitance	C _{ISS}	V _{DS} =25V, V _{GS} =0V, f=1MHz		350		pF
Output Capacitance	C _{OSS}			260		pF
Reverse Transfer Capacitance	C _{RSS}			56		pF
SWITCHING CHARACTERISTICS						
Total Gate Charge	Q _G	V _{DS} =50V, V _{GS} =10V, I _D =1.3A, I _G =100μA (Note 1, 2)		37		nC
Gate-Source Charge	Q _{GS}			4.8		nC
Gate-Drain Charge	Q _{GD}			5.8		nC
Turn-On Delay Time	t _{D(ON)}	V _{DD} =30V, V _{GS} =10V, I _D =0.5A, R _G =25Ω (Note 1, 2)		50		ns
Turn-On Rise Time	t _R			33		ns
Turn-Off Delay Time	t _{D(OFF)}			74		ns
Turn-Off Fall Time	t _F			27		ns
SOURCE- DRAIN DIODE RATINGS AND CHARACTERISTICS						
Maximum Continuous Drain-Source Diode Forward Current	I _S				4.0	A
Maximum Pulsed Drain-Source Diode Forward Current	I _{SM}				17.6	A
Drain-Source Diode Forward Voltage	V _{SD}	V _{GS} = 0V, I _S = 4.0A			1.4	V
Reverse Recovery Time	t _{rr}	I _S =4.0A, V _{GS} =0V,		470		ns
Reverse Recovery Charge	Q _{RR}	dI _F /dt=100A/μs (Note 1)		2.2		μC

Notes: 1. Pulse Test: Pulse width≤300μs, Duty cycle≤2%

2. Essentially independent of operating temperature

■ TEST CIRCUITS AND WAVEFORMS

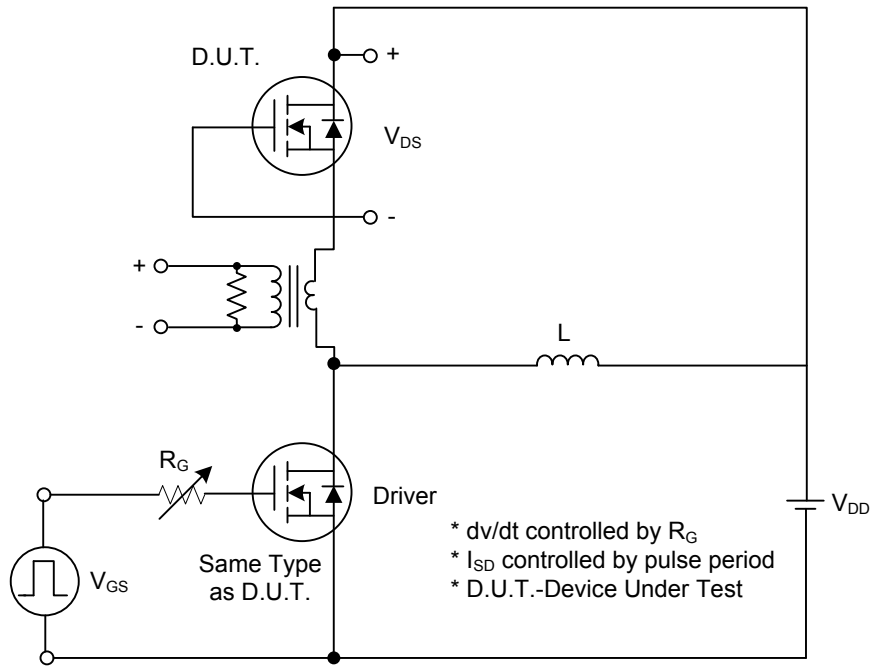

Peak Diode Recovery dv/dt Test Circuit

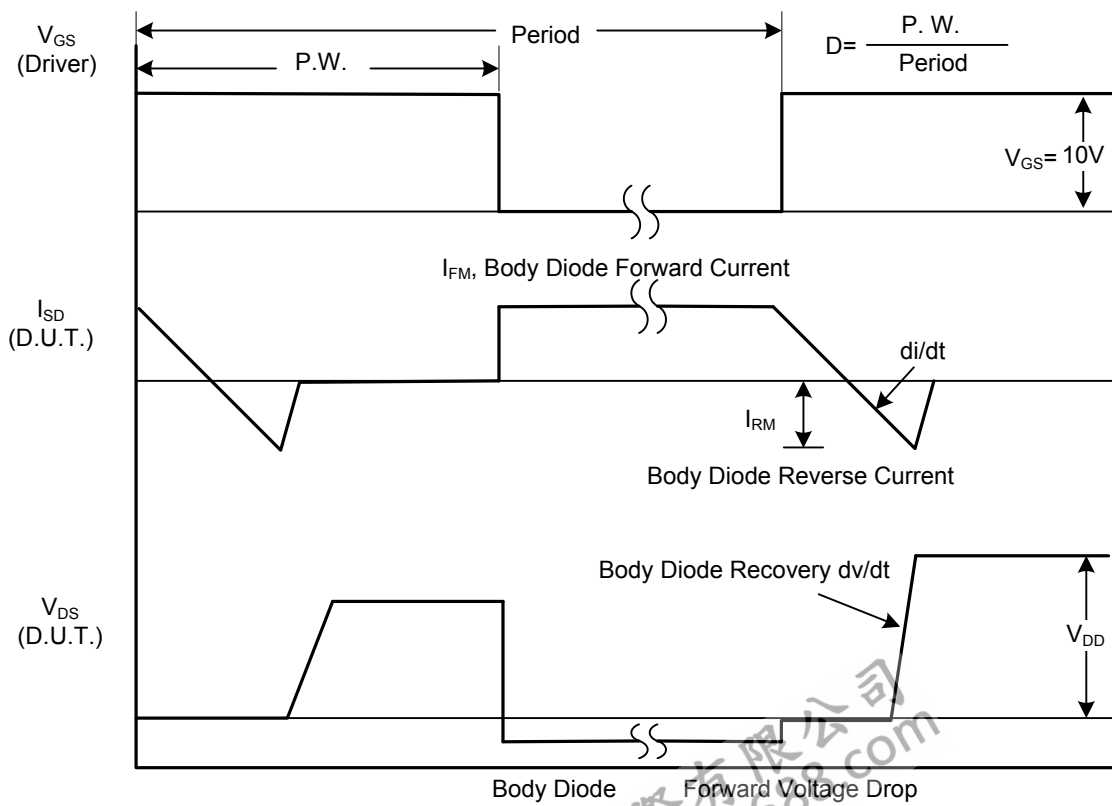

Peak Diode Recovery dv/dt Waveforms

■ TEST CIRCUITS AND WAVEFORMS (Cont.)

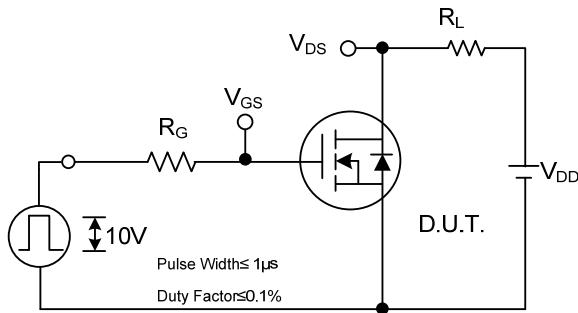

Switching Test Circuit

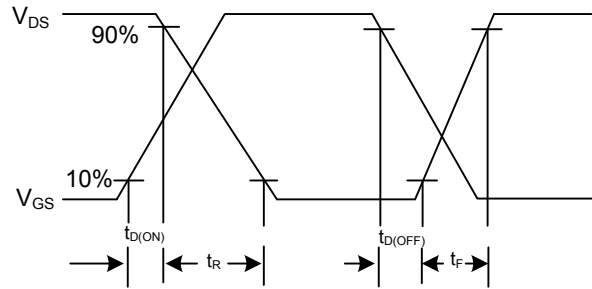

Switching Waveforms

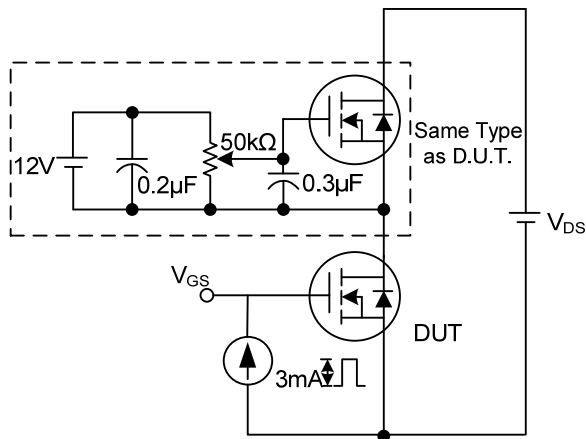

Gate Charge Test Circuit

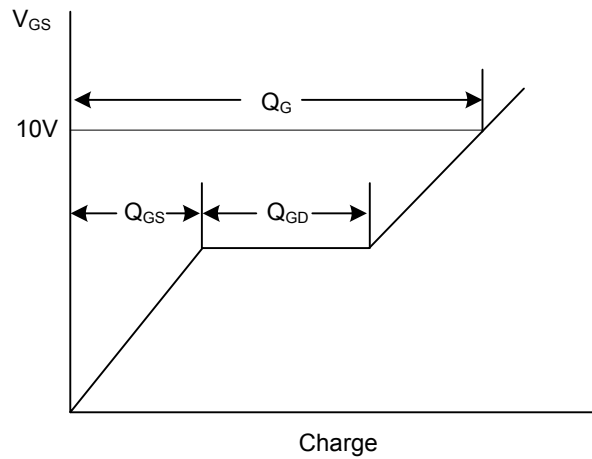

Gate Charge Waveform

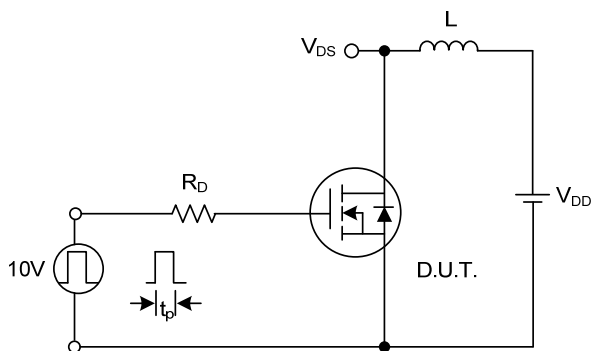

Unclamped Inductive Switching Test Circuit

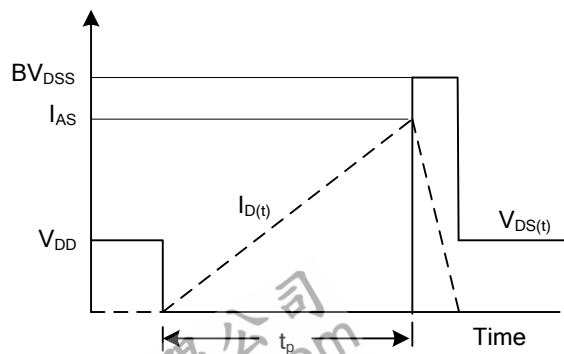

Unclamped Inductive Switching Waveforms

UTC assumes no responsibility for equipment failures that result from using products at values that exceed, even momentarily, rated values (such as maximum ratings, operating condition ranges, or other parameters) listed in products specifications of any and all UTC products described or contained herein. UTC products are not designed for use in life support appliances, devices or systems where malfunction of these products can be reasonably expected to result in personal injury. Reproduction in whole or in part is prohibited without the prior written consent of the copyright owner. The information presented in this document does not form part of any quotation or contract, is believed to be accurate and reliable and may be changed without notice.