



4N80-CS

Power MOSFET

4A, 800V N-HANNEL POWER MOSFET

■ DESCRIPTION

The UTC **4N80-CS** is a high voltage power MOSFET combines advanced trench MOSFET designed to have better characteristics, such as fast switching time, low gate charge, low on-state resistance and high rugged avalanche characteristics. This power MOSFET is usually used in high speed switching applications of switching power supplies and adaptors.

■ FEATURES

- * $R_{DS(ON)} \leq 3.8\Omega @ V_{GS}=10V, I_D=2.0A$
- * Low Reverse Transfer Capacitance
- * Fast Switching Capability
- * Avalanche Energy Specified
- * Improved dv/dt Capability, High Ruggedness

■ SYMBOL

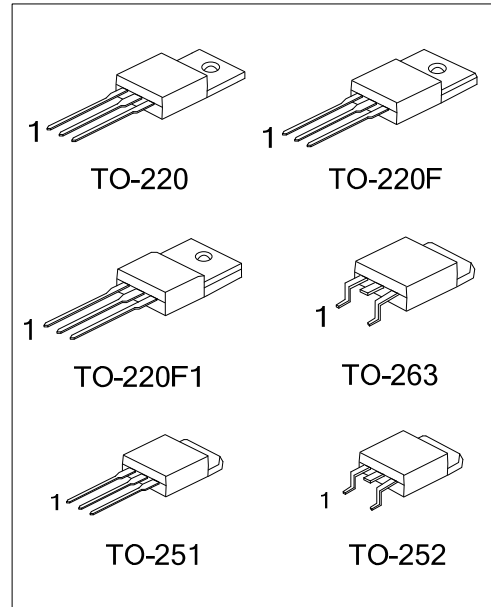
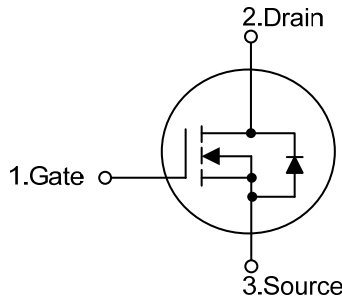

■ ORDERING INFORMATION

Ordering Number		Package	Pin Assignment			Packing
Lead Free	Halogen Free		1	2	3	
4N80L-TA3-T	4N80G-TA3-T	TO-220	G	D	S	Tube
4N80L-TF3-T	4N80G-TF3-T	TO-220F	G	D	S	Tube
4N80L-TF1-T	4N80G-TF1-T	TO-220F1	G	D	S	Tube
4N80L-TM3-T	4N80G-TM3-T	TO-251	G	D	S	Tube
4N80L-TN3-R	4N80G-TN3-R	TO-252	G	D	S	Tape Reel
4N80L-TQ2-T	4N80G-TQ2-T	TO-263	G	D	S	Tube
4N80L-TQ2-R	4N80G-TQ2-R	TO-263	G	D	S	Tape Reel

Note: Pin Assignment: G: Gate D: Drain S: Source

<p>4N80G-TA3-T</p> <p>(1)Packing Type</p> <p>(2)Package Type</p> <p>(3)Green Package</p>	<p>(1) T: Tube, R: Tape Reel</p> <p>(2) TA3: TO-220, TF3: TO-220F, TF1: TO-220F1, TM3: TO-251, TN3: TO-252, TQ2: TO-263</p> <p>(3) G: Halogen Free and Lead Free, L: Lead Free</p>
--	--

MARKING

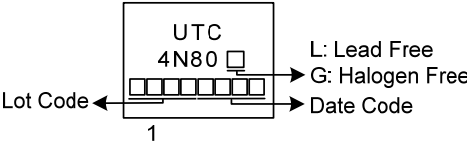

FLYING 汎翔國際有限公司
www.flying1688.com

■ ABSOLUTE MAXIMUM RATINGS ($T_C = 25^\circ\text{C}$, unless otherwise specified)

PARAMETER		SYMBOL	RATINGS	UNIT
Drain-Source Voltage		V_{DSS}	800	V
Gate-Source Voltage		V_{GSS}	± 30	V
Drain Current	Continuous	I_D	4	A
	Pulsed (Note 2)	I_{DM}	8	A
Avalanche Energy	Single Pulsed (Note 3)	E_{AS}	90	mJ
Peak Diode Recovery dv/dt (Note 4)		dv/dt	2.86	V/ns
Power Dissipation	TO-220/TO-263	P_D	85	W
	TO-220F/TO-220F1		31	W
	TO-251/TO-252		45	W
Junction Temperature		T_J	+150	$^\circ\text{C}$
Storage Temperature		T_{STG}	-55 ~ +150	$^\circ\text{C}$

Notes: 1. Absolute maximum ratings are those values beyond which the device could be permanently damaged.

Absolute maximum ratings are stress ratings only and functional device operation is not implied.

2. Repetitive Rating : Pulse width limited by maximum junction temperature.

3. $L=10\text{mH}$, $I_{AS}=4.24\text{A}$, $V_{DD}=50\text{V}$, $R_G=25\ \Omega$, Starting $T_J = 25^\circ\text{C}$

4. $I_{SD}\leq 4.0\text{A}$, $di/dt\leq 200\text{A}/\mu\text{s}$, $V_{DD}\leq BV_{DSS}$, Starting $T_J = 25^\circ\text{C}$

■ THERMAL DATA

PARAMETER		SYMBOL	RATINGS	UNIT
Junction to Ambient	TO-220/TO-220F	θ_{JA}	62.5	$^\circ\text{C}/\text{W}$
	TO-220F1/TO-263			
	TO-251/TO-252			
Junction to Case	TO-220/TO-263	θ_{JC}	1.47	$^\circ\text{C}/\text{W}$
	TO-220F/TO-220F1		4.03	$^\circ\text{C}/\text{W}$
	TO-251/TO-252		2.7 (Note)	$^\circ\text{C}/\text{W}$

Note: The data tested by surface mounted on a 1 inch² FR-4 board with 2OZ copper.

■ ELECTRICAL CHARACTERISTICS ($T_J = 25^\circ\text{C}$, unless otherwise specified)

PARAMETER	SYMBOL	TEST CONDITIONS	MIN	TYP	MAX	UNIT
OFF CHARACTERISTICS						
Drain-Source Breakdown Voltage	BV_{DSS}	$V_{GS}=0V, I_D=250\mu A$	800			V
Drain-Source Leakage Current	I_{DSS}	$V_{DS}=800V, V_{GS}=0V$			10	μA
Gate-Source Leakage Current	I_{GSS}	$V_{GS}=\pm 30V, V_{DS}=0V$			± 100	nA
ON CHARACTERISTICS						
Gate Threshold Voltage	$V_{GS(TH)}$	$V_{DS}=V_{GS}, I_D=250\mu A$	3.0		5.0	V
Static Drain-Source On-State Resistance	$R_{DS(ON)}$	$V_{GS}=10V, I_D=2.0A$			3.8	Ω
DYNAMIC CHARACTERISTICS						
Input Capacitance	C_{ISS}	$V_{DS}=25V, V_{GS}=0V, f=1MHz$		525		pF
Output Capacitance	C_{OSS}			70		pF
Reverse Transfer Capacitance	C_{RSS}			7.7		pF
SWITCHING CHARACTERISTICS						
Total Gate Charge (Note 1)	Q_G	$V_{DS}=640V, V_{GS}=10V, I_D=4A$ $I_G=1mA$ (Note 1, 2)		15		nC
Gate-Source Charge	Q_{GS}			5.4		nC
Gate-Drain Charge	Q_{GD}			4		nC
Turn-On Delay Time (Note 1)	$t_{D(ON)}$	$V_{DD}=100V, V_{GS}=10V, I_D=4A,$ $R_G=25\Omega$ (Note 1, 2)		12		ns
Turn-On Rise Time	t_R			42		ns
Turn-Off Delay Time	$t_{D(OFF)}$			50		ns
Turn-Off Fall Time	t_F			30		ns
SOURCE- DRAIN DIODE RATINGS AND CHARACTERISTICS						
Maximum Continuous Drain-Source Diode Forward Current	I_S				4	A
Maximum Pulsed Drain-Source Diode Forward Current	I_{SM}				8	A
Drain-Source Diode Forward Voltage (Note 1)	V_{SD}	$I_S=4.0A, V_{GS}=0V$			1.4	V
Body Diode Reverse Recovery Time (Note 1)	t_{rr}	$I_S=4.0A, V_{GS}=0V,$ $dI_F/dt=100A/\mu s$		620		ns
Body Diode Reverse Recovery Charge	Q_{rr}			3.2		μC

Notes: 1. Pulse Test: Pulse width $\leq 300\mu s$, Duty cycle $\leq 2\%$.

2. Essentially independent of operating temperature.

■ TEST CIRCUITS AND WAVEFORMS

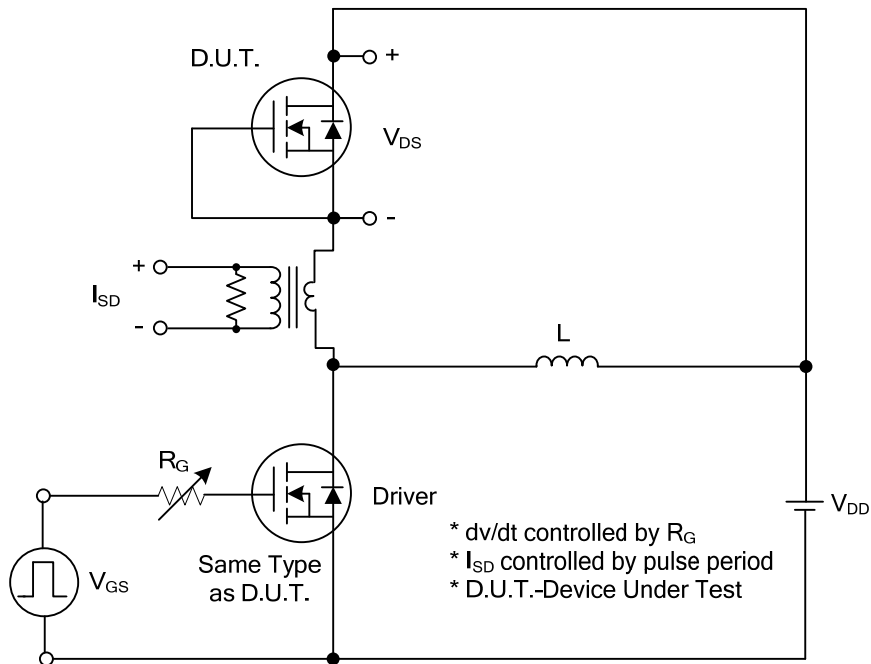

Peak Diode Recovery dv/dt Test Circuit

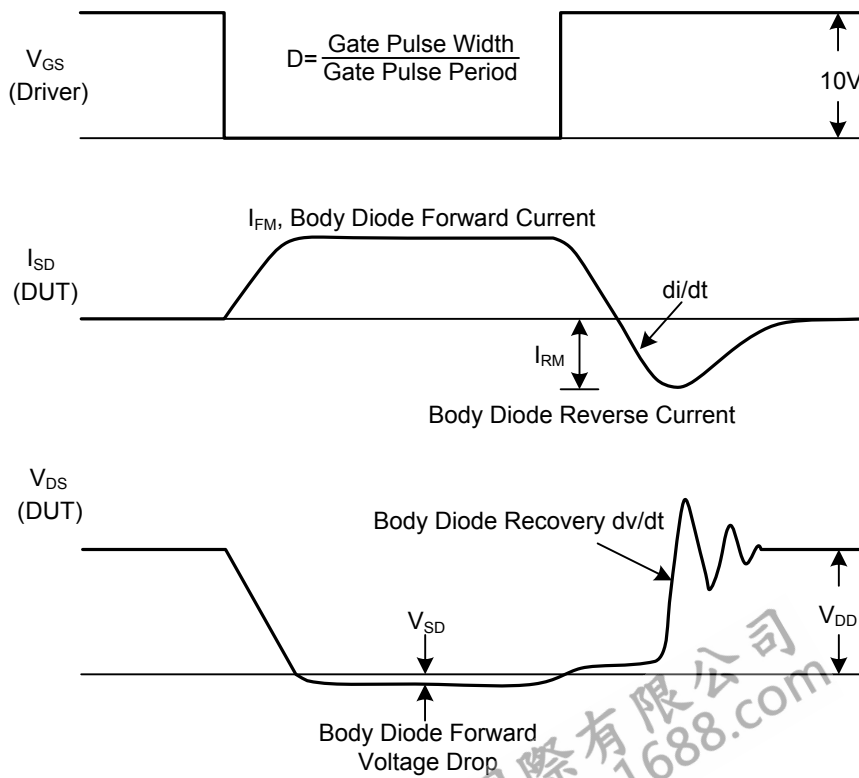

Peak Diode Recovery dv/dt Waveforms

TEST CIRCUITS AND WAVEFORMS

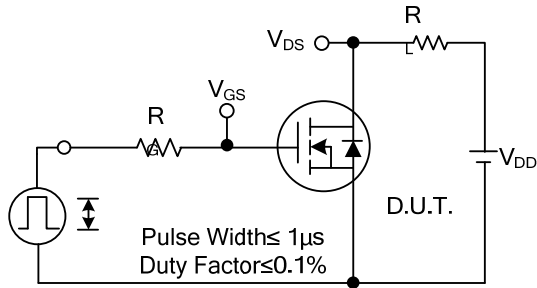

Switching Test Circuit

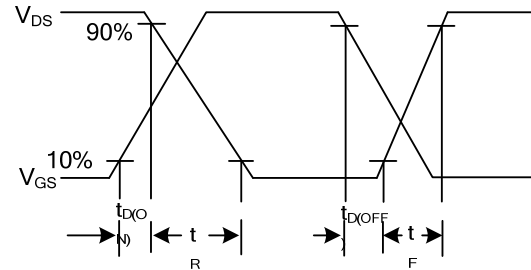

Switching Waveforms

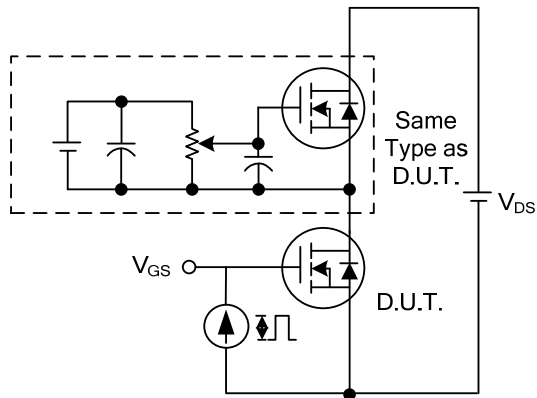

Gate Charge Test Circuit

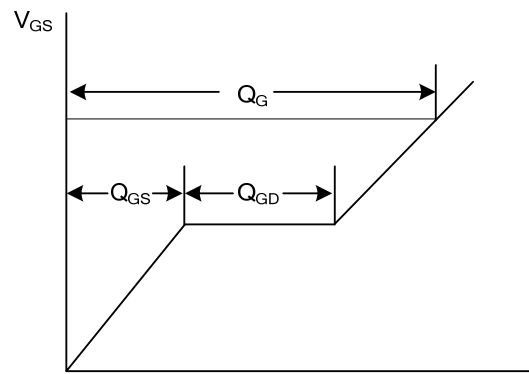

Charge

Gate Charge Waveform

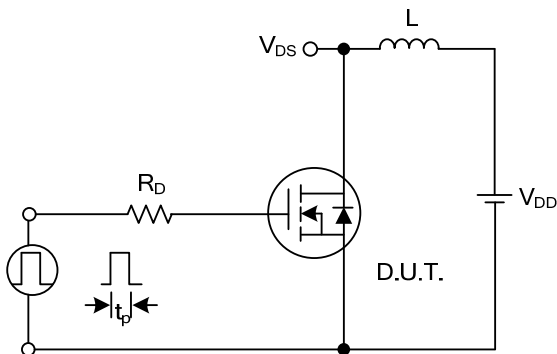

Unclamped Inductive Switching Test Circuit

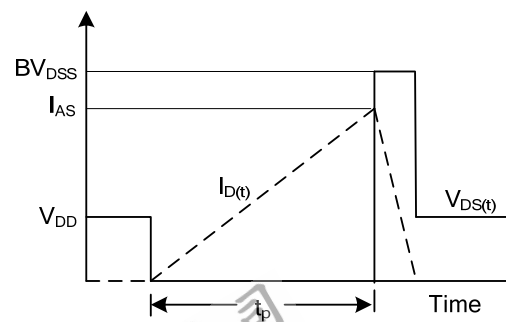

Unclamped Inductive Switching Waveforms

TYPICAL CHARACTERISTICS

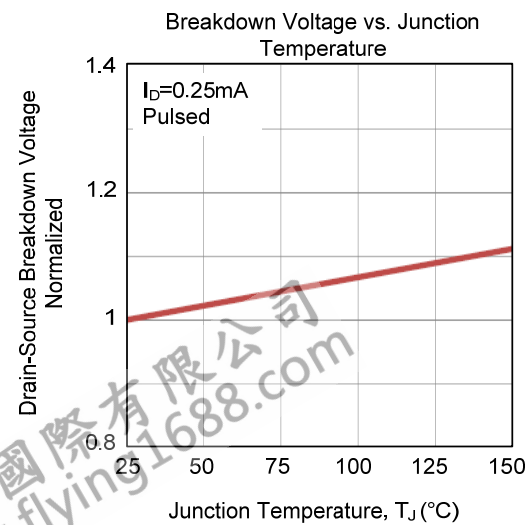
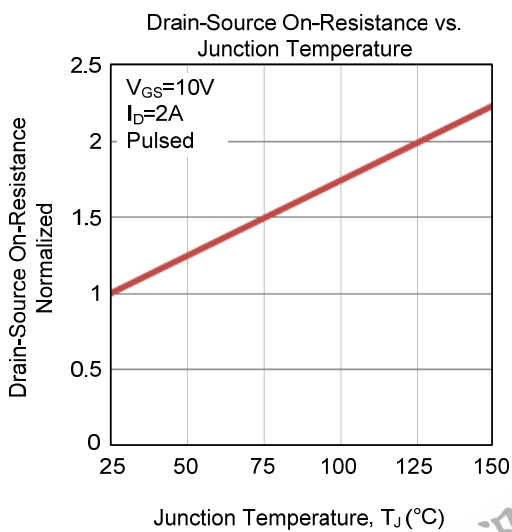
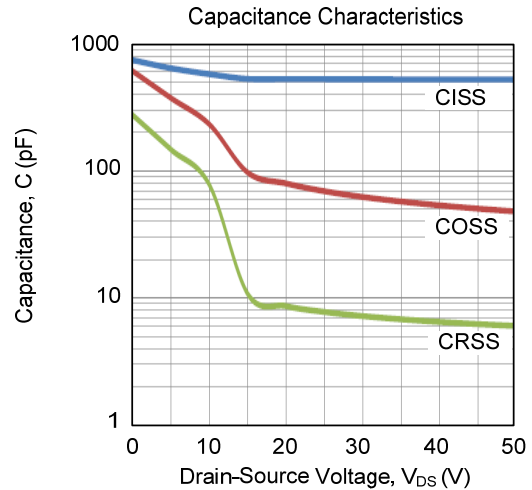
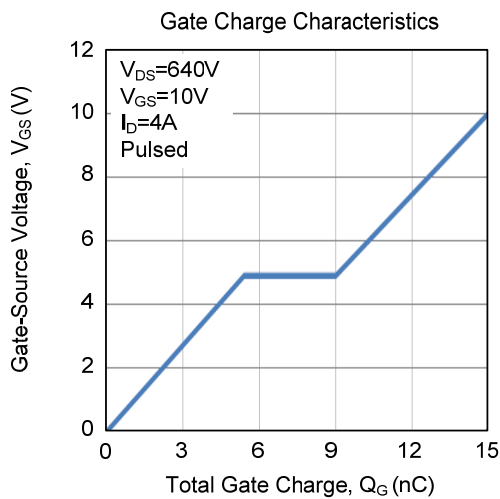
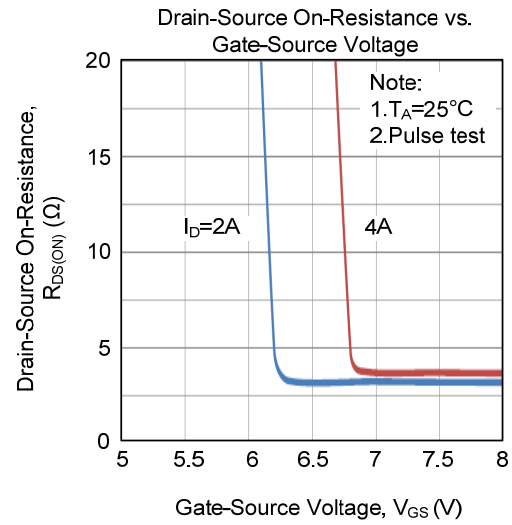
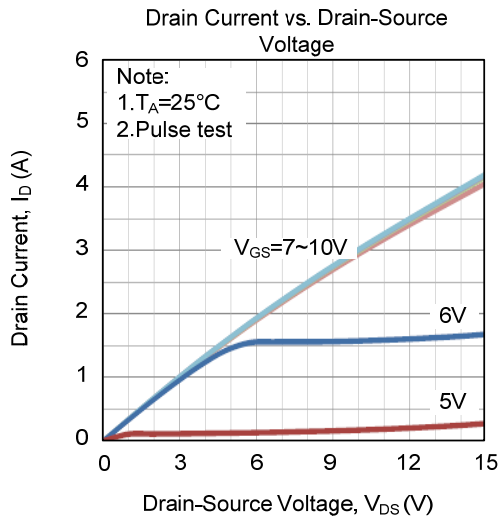

TYPICAL CHARACTERISTICS (Cont.)

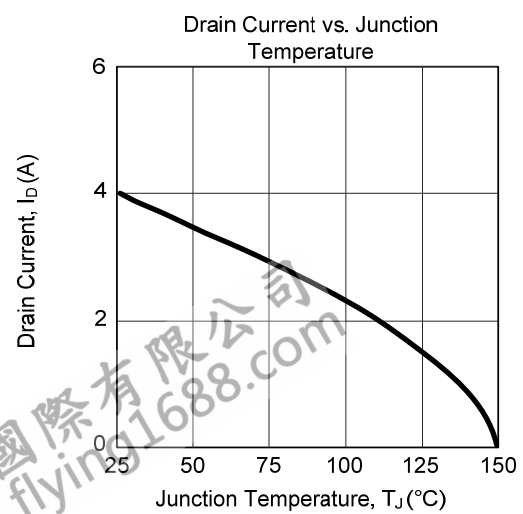
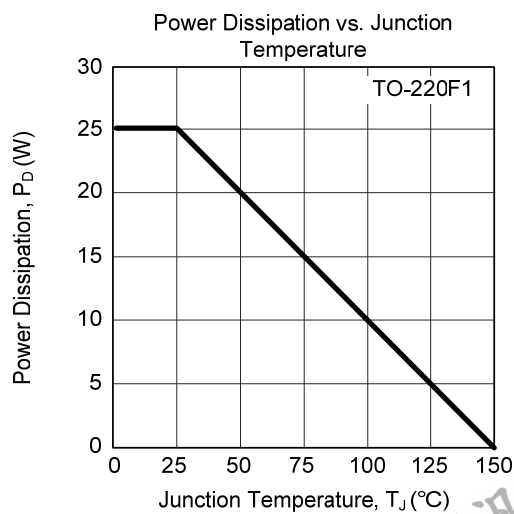
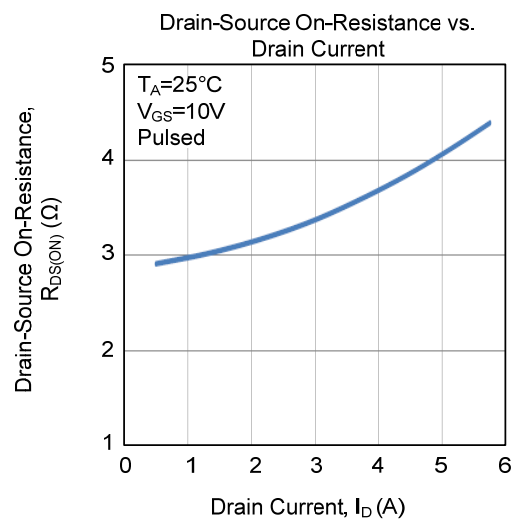
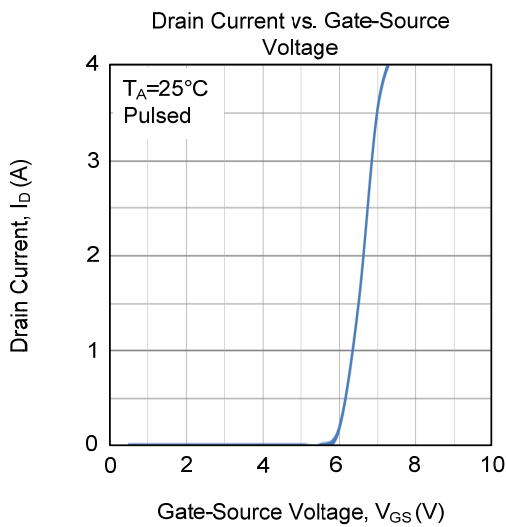
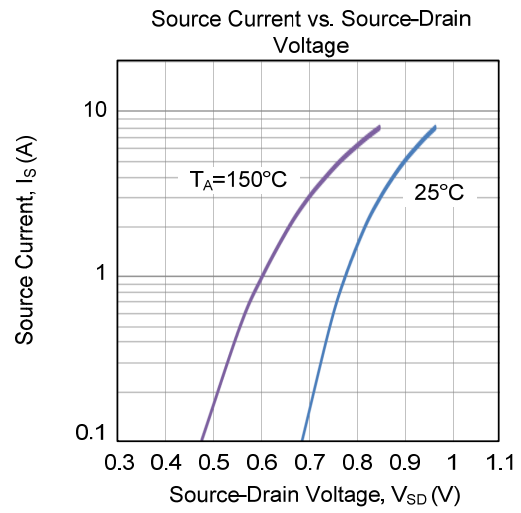
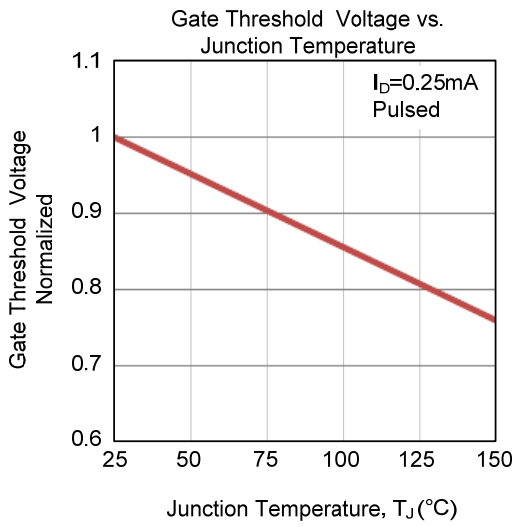

■ TYPICAL CHARACTERISTICS (Cont.)

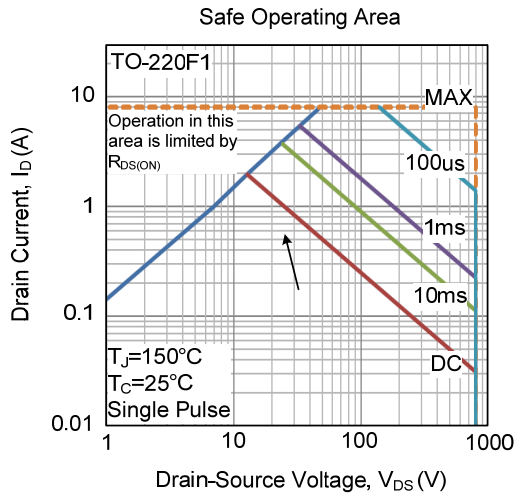

UTC assumes no responsibility for equipment failures that result from using products at values that exceed, even momentarily, rated values (such as maximum ratings, operating condition ranges, or other parameters) listed in products specifications of any and all UTC products described or contained herein. UTC products are not designed for use in life support appliances, devices or systems where malfunction of these products can be reasonably expected to result in personal injury. Reproduction in whole or in part is prohibited without the prior written consent of the copyright owner. UTC reserves the right to make changes to information published in this document, including without limitation specifications and product descriptions, at any time and without notice. This document supersedes and replaces all information supplied prior to the publication hereof.