



4N90-FCQ

Preliminary

Power MOSFET

4A, 900V N-CHANNEL POWER MOSFET

DESCRIPTION

The UTC 4N90-FCQ provide excellent $R_{DS(ON)}$, low gate charge and operation with low gate voltages. This device is suitable for use as a load switch or in PWM applications.

FEATURES

- * $R_{DS(ON)} \leq 5.4 \Omega @ V_{GS}=10V, I_D=2.0A$
- * Fast switching capability
- * Avalanche energy specified
- * Improved dv/dt capability, high ruggedness

SYMBOL

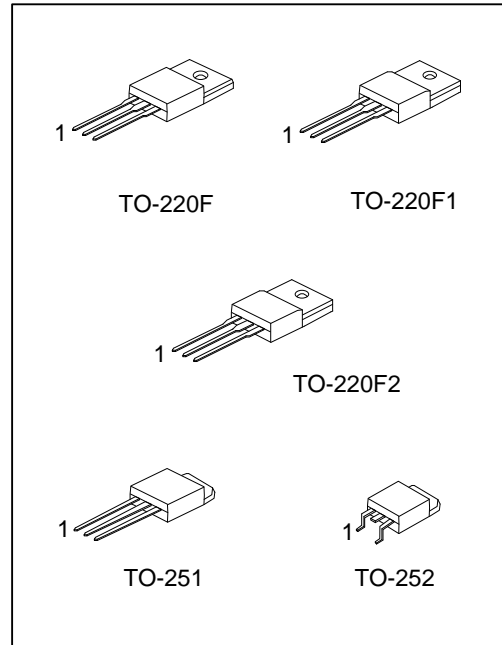
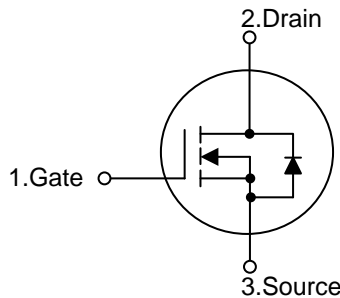

ORDERING INFORMATION

Ordering Number		Package	Pin Assignment			Packing
Lead Free	Halogen Free		1	2	3	
4N90L-TF1-T	4N90G-TF1-T	TO-220F1	G	D	S	Tube
4N90L-TF2-T	4N90G-TF2-T	TO-220F2	G	D	S	Tube
4N90L-TF3-T	4N90G-TF3-T	TO-220F	G	D	S	Tube
4N90L-TM3-T	4N90G-TM3-T	TO-251	G	D	S	Tube
4N90L-TN3-R	4N90G-TN3-R	TO-252	G	D	S	Tape Reel

Note: Pin Assignment: G: Gate D: Drain S: Source

<p>4N90G-TF1-T</p> <p>(1) Packing Type (2) Package Type (3) Green Package</p>	<p>(1) T: Tube, R: Tape Reel (2) TF3: TO-220F, TF1: TO-220F1, TF2: TO-220F2 TM3: TO-251, TN3: TO-252 (3) G: Halogen Free and Lead Free, L: Lead Free</p>
---	--

MARKING

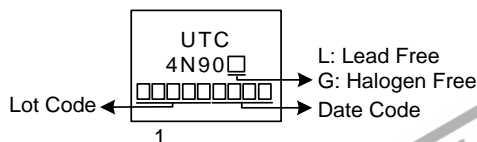

■ **ABSOLUTE MAXIMUM RATINGS** ($T_C=25^{\circ}\text{C}$, unless otherwise specified)

PARAMETER		SYMBOL	RATINGS	UNIT
Drain-Source Voltage		V_{DSS}	900	V
Gate-Source Voltage		V_{GSS}	± 30	V
Continuous Drain Current		I_D	4	A
Pulsed Drain Current (Note 2)		I_{DM}	8	A
Avalanche Energy (Note 3)	Single Pulsed	E_{AS}	126	mJ
Peak Diode Recovery dv/dt (Note 4)		dv/dt	2.9	V/ns
Power Dissipation	TO-220F/TO-220F1	P_D	26	W
	TO-220F2			
	TO-251/TO-252		46	W
Junction Temperature		T_J	+150	$^{\circ}\text{C}$
Storage Temperature		T_{STG}	-55 ~ +150	$^{\circ}\text{C}$

Notes: 1. Absolute maximum ratings are those values beyond which the device could be permanently damaged.

Absolute maximum ratings are stress ratings only and functional device operation is not implied.

2. Repetitive Rating: Pulse width limited by maximum junction temperature.

3. $L=30\text{mH}$, $I_{AS}=2.9\text{A}$, $V_{DD}=100\text{V}$, $R_G=25\ \Omega$, Starting $T_J = 25^{\circ}\text{C}$

4. $I_{SD}\leq 4.0\text{A}$, $di/dt\leq 200\text{A}/\mu\text{s}$, $V_{DD}\leq BV_{DSS}$, Starting $T_J = 25^{\circ}\text{C}$

■ **THERMAL DATA**

PARAMETER		SYMBOL	RATING	UNIT
Junction to Ambient	TO-220F/TO-220F1	θ_{JA}	62.5	$^{\circ}\text{C}/\text{W}$
	TO-220F2			
	TO-251/TO-252		110	$^{\circ}\text{C}/\text{W}$
Junction to Case	TO-220F/TO-220F1	θ_{JC}	4.81	$^{\circ}\text{C}/\text{W}$
	TO-220F2			
	TO-251/TO-252		2.7 (Note)	$^{\circ}\text{C}/\text{W}$

Note: Device mounted on FR-4 substrate PC board, 2oz copper, with 1inch square copper plate.

■ **ELECTRICAL CHARACTERISTICS** ($T_J=25^{\circ}\text{C}$, unless otherwise specified)

PARAMETER	SYMBOL	TEST CONDITIONS	MIN	TYP	MAX	UNIT
OFF CHARACTERISTICS						
Drain-Source Breakdown Voltage	BV_{DSS}	$V_{GS}=0V, I_D=250\mu A$	900			V
Drain-Source Leakage Current	I_{DSS}	$V_{DS}=900V, V_{GS}=0V$			10	μA
Gate-Source Leakage Current	Forward	$V_{GS}=30V, V_{DS}=0V$ $V_{GS}=-30V, V_{DS}=0V$			100	nA
	Reverse				-100	nA
ON CHARACTERISTICS						
Gate Threshold Voltage	$V_{GS(TH)}$	$V_{DS}=V_{GS}, I_D=250\mu A$	3.0		5.0	V
Static Drain-Source On-State Resistance	$R_{DS(ON)}$	$V_{GS}=10V, I_D=2.0A$			5.4	Ω
DYNAMIC CHARACTERISTICS						
Input Capacitance	C_{ISS}	$V_{DS}=25V, V_{GS}=0V, f=1\text{MHz}$		516		pF
Output Capacitance	C_{OSS}			52		pF
Reverse Transfer Capacitance	C_{RSS}			1.9		pF
SWITCHING CHARACTERISTICS						
Total Gate Charge	Q_G	$V_{DS}=720V, V_{GS}=10V,$ $I_D=4A, I_G=1\text{mA}$ (Note 1, 2)		9		nC
Gate-Source Charge	Q_{GS}			4.6		nC
Gate-Drain Charge	Q_{GD}			0.6		nC
Turn-On Delay Time	$t_{D(ON)}$	$V_{DD}=100V, V_{GS}=10V, I_D=4A,$ $R_G=25\Omega$ (Note 1, 2)		6.4		ns
Turn-On Rise Time	t_R			14.5		ns
Turn-Off Delay Time	$t_{D(OFF)}$			10		ns
Turn-Off Fall Time	t_F			19		ns
DRAIN-SOURCE DIODE CHARACTERISTICS						
Maximum Body-Diode Continuous Current	I_S				4	A
Continuous Drain-Source Current	I_{SD}				8	A
Drain-Source Diode Forward Voltage	V_{SD}	$I_S=4A, V_{GS}=0V$			1.4	V
Reverse Recovery Time	t_{rr}	$I_F=4A, di/dt=100A/\mu s$		450		ns
Reverse Recovery Charge	Q_{rr}				6.9	

Notes: 1. Pulse Test: Pulse width $\leq 300\mu s$, Duty cycle $\leq 2\%$.

2. Essentially independent of operating temperature.

■ TEST CIRCUITS AND WAVEFORMS

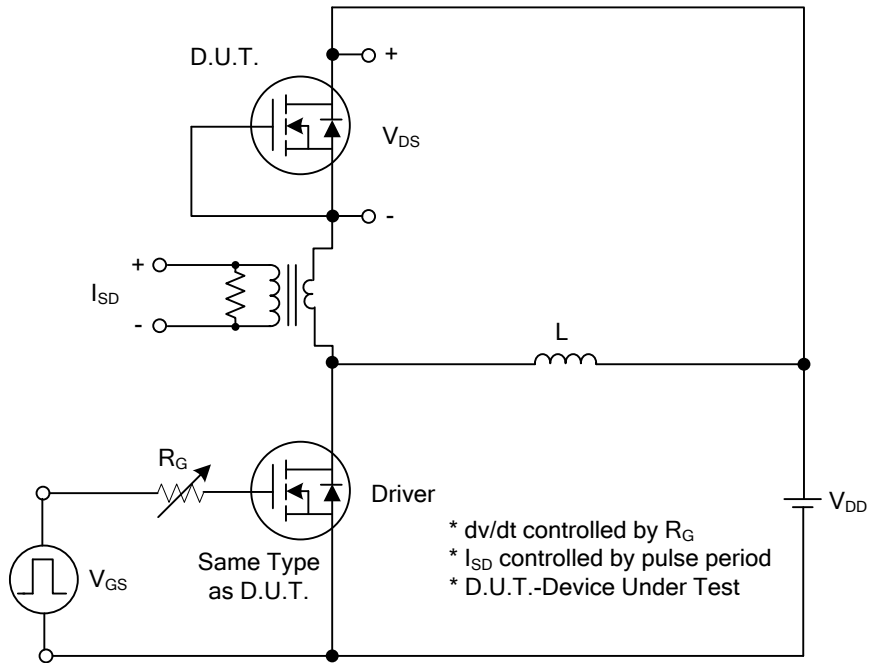

Peak Diode Recovery dv/dt Test Circuit

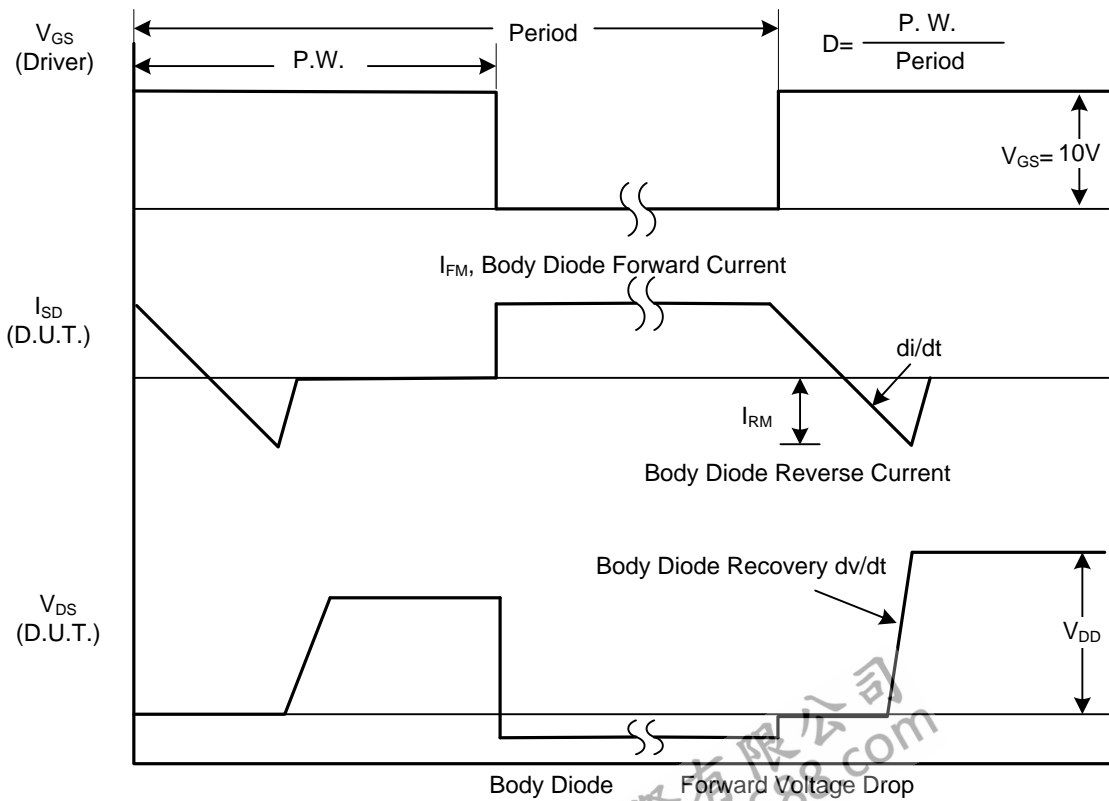

Peak Diode Recovery dv/dt Waveforms

TEST CIRCUITS AND WAVEFORMS

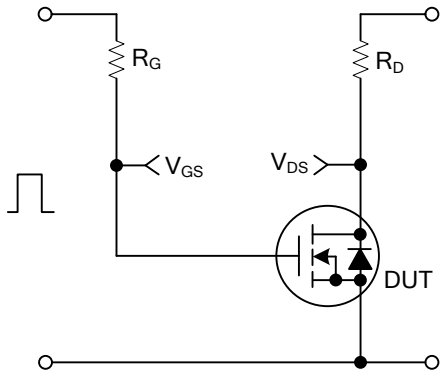

Switching Test Circuit

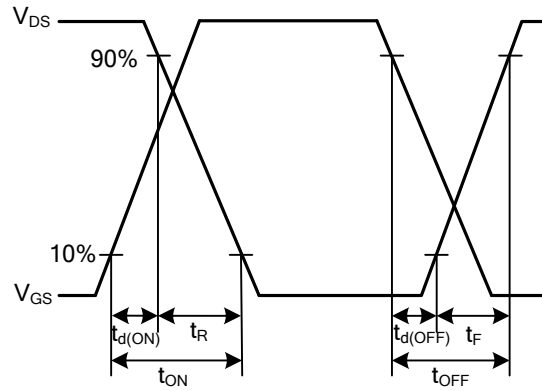

Switching Waveforms

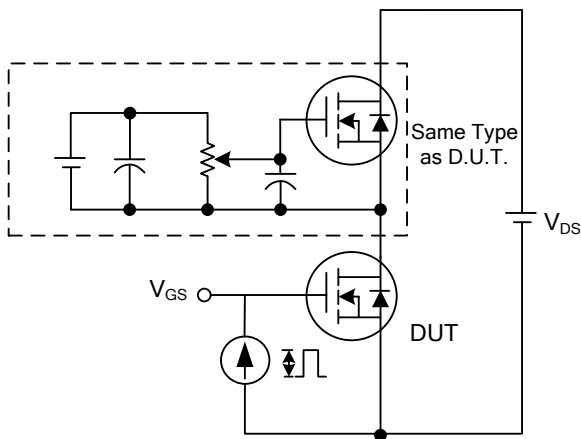

Gate Charge Test Circuit

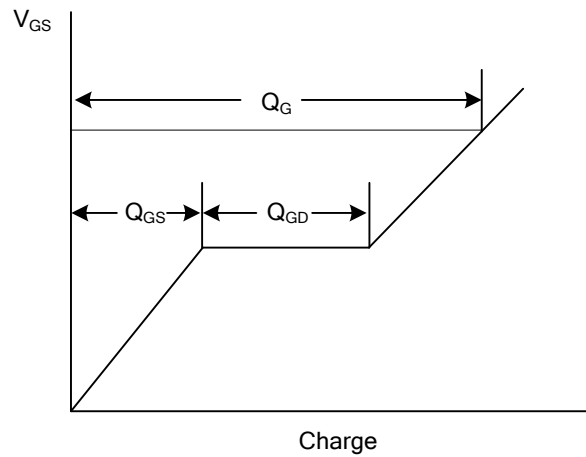

Gate Charge Waveform

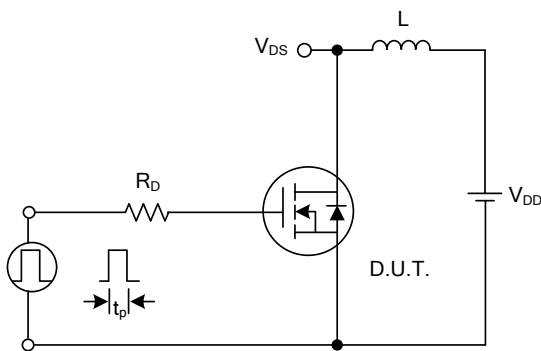

Unclamped Inductive Switching Test Circuit

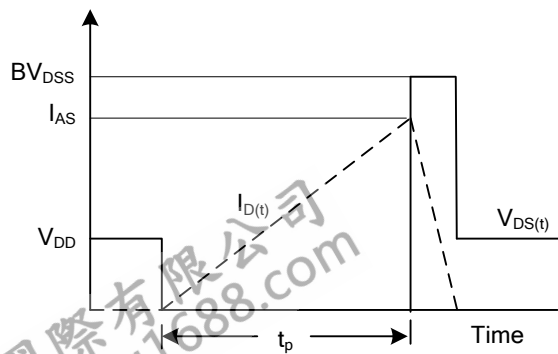

Unclamped Inductive Switching Waveforms

UTC assumes no responsibility for equipment failures that result from using products at values that exceed, even momentarily, rated values (such as maximum ratings, operating condition ranges, or other parameters) listed in products specifications of any and all UTC products described or contained herein. UTC products are not designed for use in life support appliances, devices or systems where malfunction of these products can be reasonably expected to result in personal injury. Reproduction in whole or in part is prohibited without the prior written consent of the copyright owner. UTC reserves the right to make changes to information published in this document, including without limitation specifications and product descriptions, at any time and without notice. This document supersedes and replaces all information supplied prior to the publication hereof.