



6610

CMOS IC

FREQUENCY AND CLOCK DISPLAY DRIVER

DESCRIPTION

The UTC **6610** is a frequency and clock display driver used for displaying FM/AM radio frequency or a 12 hour alarm clock. By using CMOS technology, it consumes very low power in clock display mode.

FEATURES

- * FM input with pre-scalar for radio frequency up to 150 MHz
- * AM input for radio frequency up to 30 MHz
- * 3 common, 13 segment, 1/3 bias LCD display drivers which supports 4 digits LCD display
- * On chip oscillator for external 32.768kHz crystal
- * 10.7 MHz / 70 kHz I.F. frequency offset for FM signal and 455kHz I.F. frequency offset for AM signal
- * Internal real time clock in 12 hour display mode
- * Selectable clock or frequency display
- * 1.8V to 3.3V supply voltage

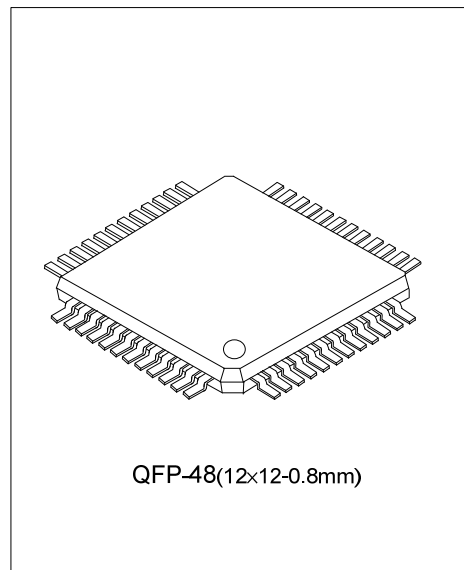

ORDERING INFORMATION

Ordering Number		Package	Packing
Lead Free	Halogen Free		
6610L-QM2-Y	6610G-QM2-Y	QFP-48	Tray

<p>6610L-QM2-Y</p> <p>(1)Packing Type (2)Package Type (3)Lead Free</p>	<p>(1) Y: Tray (2) QM2: QFP-48 (3) G: Halogen Free, L: Lead Free</p>
--	--



■ PIN CONFIGROTION

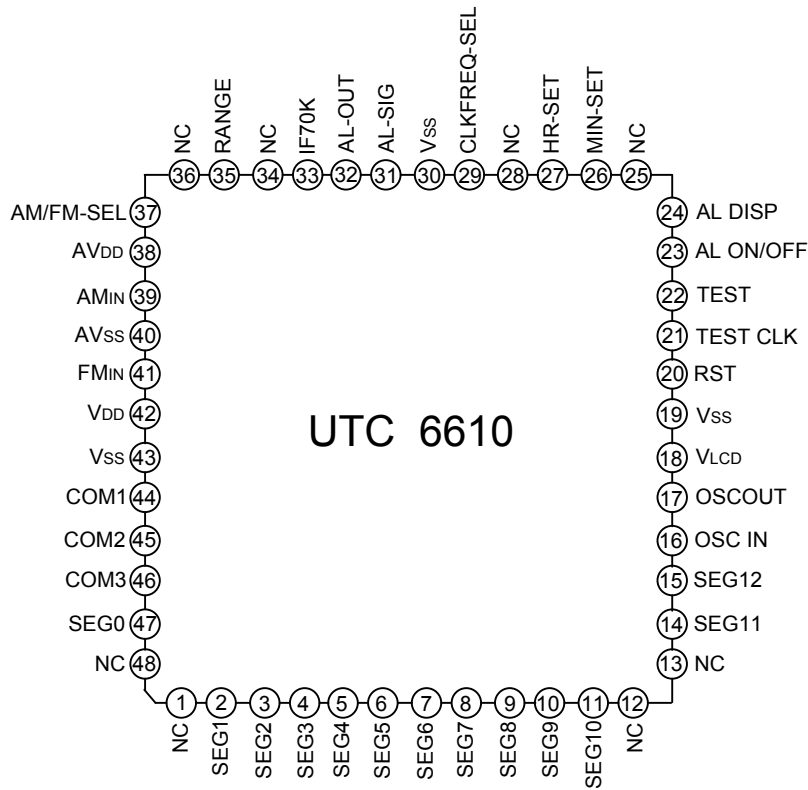

■ BLOCK DIAGRAM

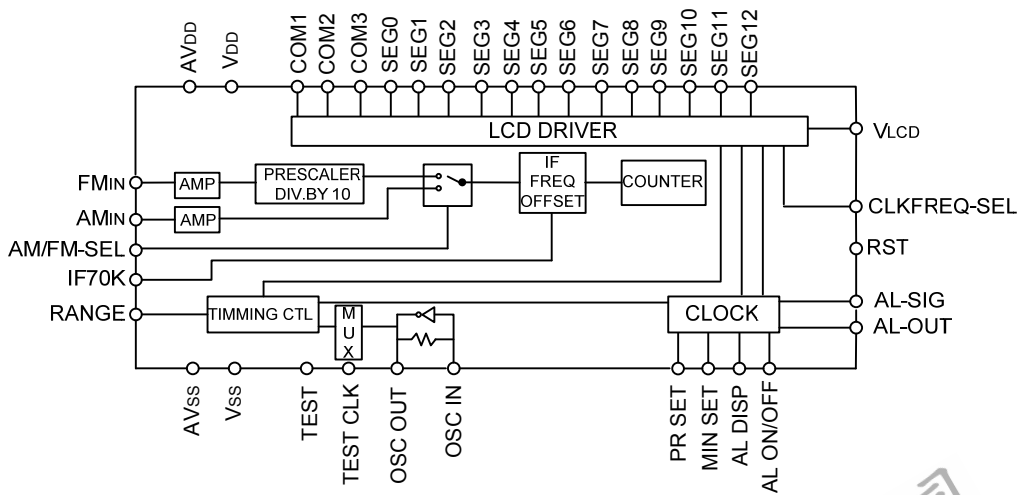

■ ABSOLUTE MAXIMUM RATINGS (Ta=25°C ,unless otherwise specified)

PARAMETER	SYMBOL	RATING	UNIT
Supply Voltage	V _{DD}	0.5 ~ 7.0	V
Input Voltage	V _{IN}	-0.5 ~ V _{DD} +0.5	V
Output Voltage	V _{OUT}	-0.5 ~ V _{DD} +0.5	V
Junction Temperature	T _J	+85	°C
Operating Temperature	T _{OPR}	-20 ~ +70	°C
Storage Temperature	T _{STG}	-40 ~ +125	°C

■ ELECTRICAL CHARACTERISTICS(Ta=25°C, V_{DD}= 3,Unless otherwise specified)

Parameter	Symbol	Test conditions	MIN	TYP	MAX	UNIT
Internal LCD Reference Voltage	V _{LCD}	respect to V _{DD}	2	2.25	2.5	V
Open Drain Low Level Voltage	V _{OLOC}	V _{DD} =3V, I _{SINK} =10mA			0.5	V
Low Level Input Voltage	V _{IL}				0.3V _{DD}	V
High Level Input Voltage	V _{IH}		0.7V _{DD}			V
Low Level Output Voltage	V _{OL}	V _{DD} =3V, I _{SINK} =4mA			0.4	V
High Level Output Voltage	V _{OH}	V _{DD} =3V, I _{SOURCE} =-4mA	V _{DD} -0.5			V
Schmitt Trigger Positive Threshold	V _{T+}	V _{DD} =3V		2.3	2.4	V
Schmitt Trigger Negative Threshold	V _{T-}	V _{DD} =3V	0.6	0.9		V
Supply Voltage	V _{DD}					
VDD Supply Current Consumption	I _{DD1}	frequency mode		1.8	3.6	mA
	I _{DD2}	clock mode		55	110	μA
LCD Drive Current consumption	I _{LCD}	all segments on			5	μA
LCD Frame Frequency	F _{LCD}			32		Hz
Oscillator Frequency	F _{OSC}			32.768		kHz
FM Input Frequency	F _{FM}	V _{IN} = 0.3 V _{PP}	11.0		150	MHz
AM Input Frequency	F _{AM}	V _{IN} = 0.3 V _{PP}	0.5		30	MHz
FM Input impedance	R _{IN(FM)}	F _{FM} =120MHz		150		Ω
AM Input impedance	R _{IN(AM)}	F _{AM} =12MHz		2.0		kΩ
Schmitt Trigger Input Resistance	R _{IN+/-}	pull-up or pull-down		75		kΩ
Reset Pin pull-up Resistance	R _{IN-UP}			750		kΩ

■ FUNCTIONAL DESCRIPTION

1. RADIO FREQUENCY DISPLAY OPERATION (DTS MODE):

The FM and AM local oscillator output generated from the external RF receiver enters a high gain input comparator through the FMIN and the AMIN pins respectively. The FM signal then routes through a divide-by-10 dynamic pre-scalar. Depending on the state of the AM/FM-SEL pin, the FM and AM signal will be selected and enters the IF frequency offset block. Depending on the FM/AM selection, 10.7MHz/70kHz or 455kHz

I.F. frequency will be subtracted or added from the input signal.

■ LCD DISPLAY RANGE:

MODE	RANGE	DISPLAY RANGE (ON LCD)	STEP	RESOLUTION
FM	H	11.00 MHz to 99.99 MHz	10kHz	1kHz
	L	11.00 MHz to 149.9 kHz	100kHz	10kHz
AM	H	500 kHz to 9999 kHz	1kHz	100kHz
	L	0.5 MHz to 29.99 MHz	10kHz	1kHz

Note:1 When counter frequency overflow, MSB will not be displayed.

■ IF OFFSET FOR DIFFERENT APPLICATION:

IF70K	AM/FM-SEL	IF Offset	Operation
0	0	+10.7MHz	Display FM input frequency 10.7MHz
0	1	+455kHz	Display AM input frequency 455kHz
1	0	-70 kHz*	Display FM input frequency +70kHz
1	1	+455kHz	Display AM input frequency 455kHz

* Suitable to use with TDA7088.

2. CLOCK FUNCTION:

(1) The clock will be advanced in the following flow:

PM 12:00 . PM 11:59 . AM 12:00 . 11:59

(2) The [.] sign is the second indicator and will blink at a rate of 2Hz

(3) TIME SETTING:

-- Pressing the keys combination of [TIME SET] [HR SET] or [TIME SET] [MIN SET] will enter the time setting mode.

-- One digit will be incremented after entering the alarm setting mode. Keep pressing the keys combination for more than 0.5 seconds will make the digit to be advanced at a rate of 2Hz.

(4) ALARM TIME SETTING:

-- Pressing the keys combination of [AL DISP] [HR SET] or [AL DISP] [MIN SET] will enter the alarm time setting mode. The [AL] indicator will turn on and the [.] sign will stop blinking.

-- One digit will be incremented after entering the alarm setting mode. Keep pressing the keys combination for more than 0.5 seconds will make the digit to be advanced at a rate of 2Hz.

(5) ALARM FUNTION:

-- AL OUT output pin will output an alarm frequency of 1024Hz at 0.2 sec on and 0.2 sec off.

-- AL OUT pin can be used to direct drive a piezo buzzer.

-- When alarm is active, AL OUT output can be disabled by pressing the [AL-ON/OFF] key or it will turn off automatically after 3 minutes lapse.

-- AL-SIG pin is an open drain output (active low). Once alarm is activated, AL-SIG can be disabled by pressing [AL-ON/OFF] key or it will turn off automatically after one hour time lapse.

-- When [AL DISP] is pressed, alarm setting time will be displayed on the LCD and the [AL] indicator will be on.

-- The [AL-ON/OFF] pin will toggle the [] indicator to turn on of off the alarm function. When the indicator is on, alarm function is on.

■ IF OFFSET FOR DIFFERENT APPLICATION(Cont.):

(6) 32.768kHz crystal is used for the reference frequency.

(7) After Power-on-reset (RST):

- [HR SET] and [MIN SET] keys will be disabled.
- [AL-DISP] KEY,[AL-ON/OFF] KEY AND AL-SIG output will be enabled.

3. After POWER-ON-SET(RST):

- When in clock mode, it will display and start at AM 7:00.
- When in DTS frequency mode, if CLKFREQ-SEL = High, and FMIN & AMIN pins are grounded, all LCD segments will be turned on(LCD test mode).

4. LCD pin configuration and 0 to 9 digits segments display configuration.

PIN	FUNCTION	LCD MAPPING		
		COM1	COM2	COM3
1	COM1	COM1		
2	COM2		COM2	
3	COM3			COM3
4	SEG0	kHz	MHz	
5	SEG1	AL	DIG1-c	DIG1-b
6	SEG2	DIG1-d	DIG1-g	DIG1-a
7	SEG3	DP1	DIG1-e	DIG1-f
8	SEG4	DP2	DIG2-c	DIG2-b
9	SEG5	DIG2-d	DIG2-g	DIG2-a
10	SEG6	:	DIG2-e	DIG2-f
11	SEG7	AM	DIG3-c	DIG3-b
12	SEG8	DIG3-d	DIG3-g	DIG3-a
13	SEG9		DIG3-e	DIG3-f
14	SEG10	FM	DIG4-c	DIG4-b
15	SEG11	DIG4-d	DIG4-g	DIG4-a
16	SEG12	PM	DIG4-e	DIG4-f

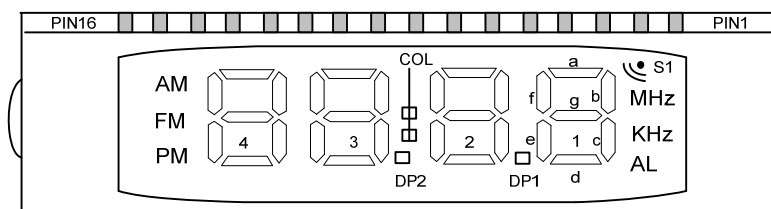

FLYING 汎翔國際有限公司
www.flying1688.com

■ LCD TIMMING WAVEFORMS

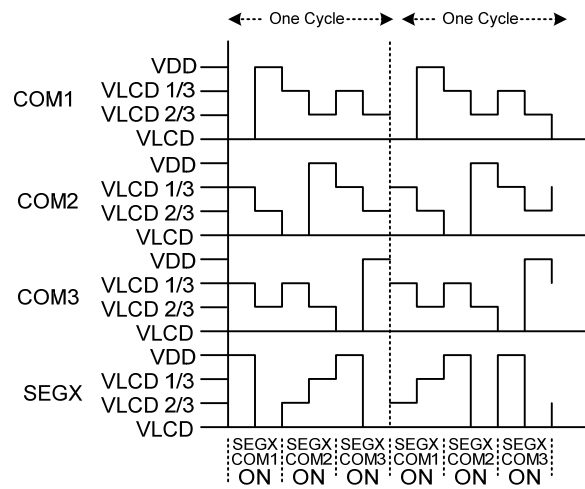

■ SUGGESTED APPLICATION

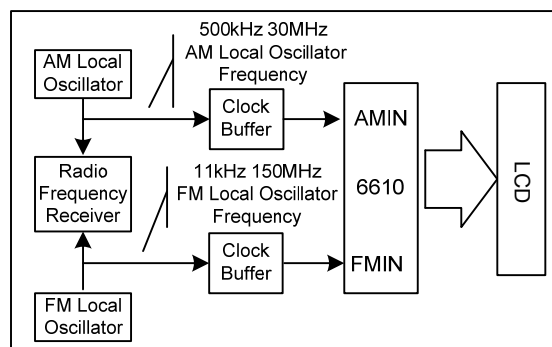

■ TYPICAL LCD LAYOUT

Counter Only Mode

PIN	COM1	COM2	COM3
1	COM1		
2		COM2	
3			COM3
4	KHz	MHz	S1
5	AL	1C	1B
6	1D	1G	1A
7	DP1	1E	1F
8	DP2	2C	2B
9	2D	2G	2A
10	COL	2E	2F
11	AM	3C	3B
12	3D	3G	3A
13		3E	3F
14	FM	4C	4B
15	4D	4G	4A
16	PM	4E	4F

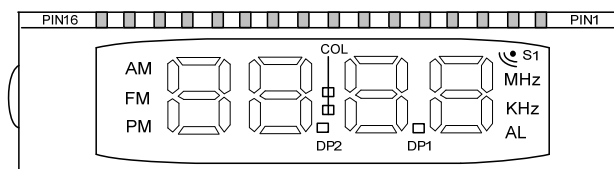

Clock and Counter Mode

PIN	COM1	COM2	COM3
1	COM1		
2		COM2	
3			COM3
4	KHz	MHz	TK
5	TS	1C	1B
6	1D	1G	1A
7	1P	1E	1F
8	2P	2C	2B
9	2D	2G	2A
10	COL	2E	2F
11		3C	3B
12	3D	3G	3A
13	S1	3E	3F
14	FM	4C	4B
15	4D	4G	4A
16	PM	4E	4F
17	AM		
18		AL	
19	MW		
20	LW		
21	SW		

■ TYPICAL LCD LAYOUT

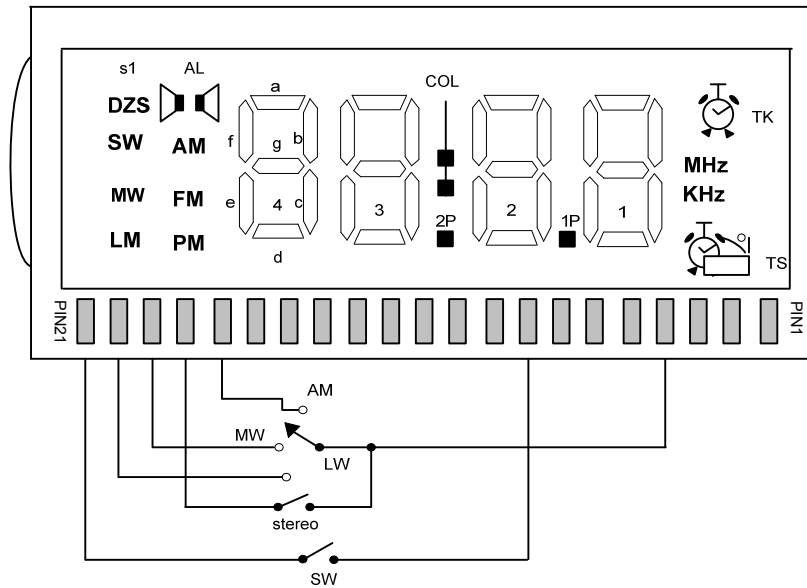

■ TYPICAL APPLICATION CIRCUITS

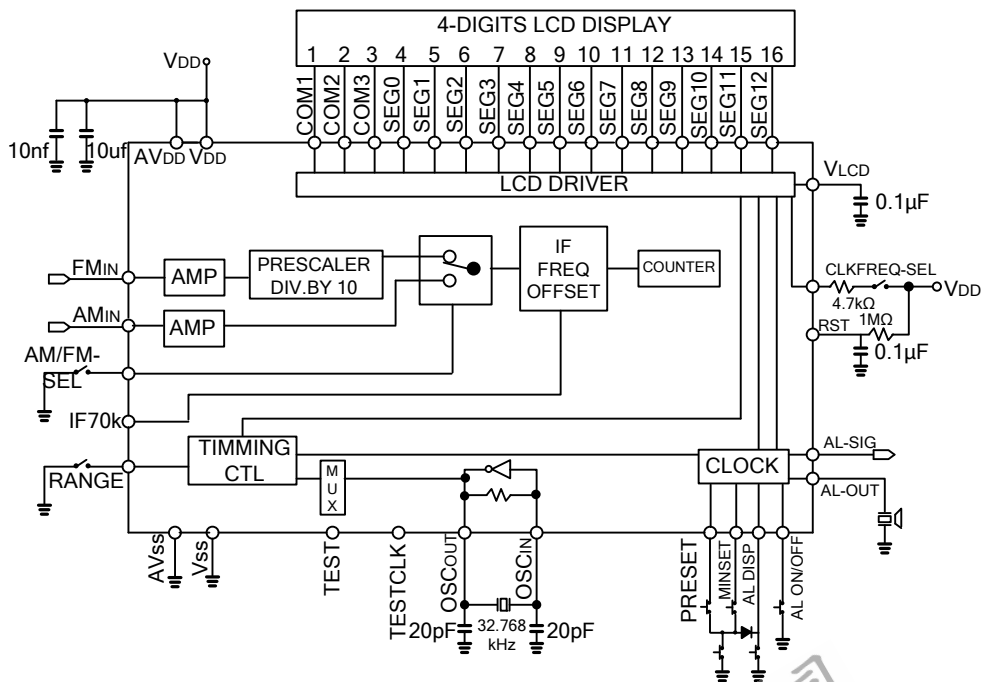

UTC assumes no responsibility for equipment failures that result from using products at values that exceed, even momentarily, rated values (such as maximum ratings, operating condition ranges, or other parameters) listed in products specifications of any and all UTC products described or contained herein. UTC products are not designed for use in life support appliances, devices or systems where malfunction of these products can be reasonably expected to result in personal injury. Reproduction in whole or in part is prohibited without the prior written consent of the copyright owner. The information presented in this document does not form part of any quotation or contract, is believed to be accurate and reliable and may be changed without notice.