



7NM90

Power MOSFET

7A, 900V N-CHANNEL SUPER-JUNCTION MOSFET

DESCRIPTION

The UTC 7NM90 is a Super Junction MOSFET Structure and is designed to have better characteristics, such as fast switching time, low gate charge, low on-state resistance and a high rugged avalanche characteristics. This power MOSFET is usually used at AC-DC converters for power applications.

FEATURES

- * $R_{DS(ON)} \leq 1.4 \Omega @ V_{GS}=10V, I_D=3.5A$
- * Fast switching capability
- * Avalanche energy tested
- * Improved dv/dt capability, high ruggedness

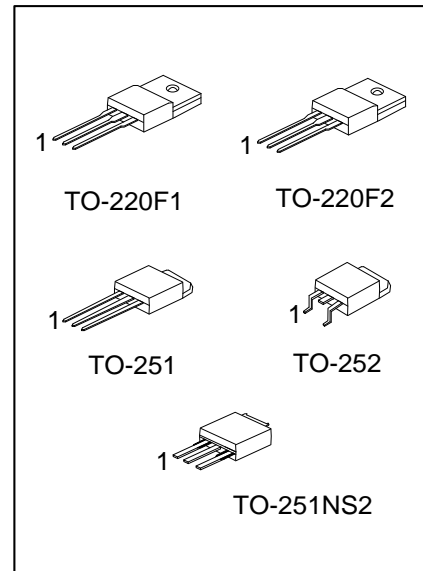

SYMBOL

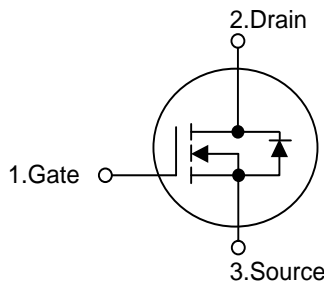

ORDERING INFORMATION

Ordering Number		Package	Pin Assignment			Packing
Lead Free	Halogen Free		1	2	3	
7NM90L-TF1-T	7NM90G-TF1-T	TO-220F1	G	D	S	Tube
7NM90L-TF2-T	7NM90G-TF2-T	TO-220F2	G	D	S	Tube
7NM90L-TM3-T	7NM90G-TM3-T	TO-251	G	D	S	Tube
7NM90L-TMN2-T	7NM90G-TMN2-T	TO-251NS2	G	D	S	Tube
7NM90L-TN3-R	7NM90G-TN3-R	TO-252	G	D	S	Tape Reel

Note: Pin Assignment: G: Gate D: Drain S: Source

<p>7NM90G-TF1-T</p> <p>(1) Packing Type</p> <p>(2) Package Type</p> <p>(3) Green Package</p>	<p>(1) T: Tube, R: Tape Reel</p> <p>(2) TF1: TO-220F1, TF2: TO-220F2, TM3: TO-251 TMN2: TO-251NS2, TN3: TO-252</p> <p>(3) G: Halogen Free and Lead Free, L: Lead Free</p>
--	---

MARKING

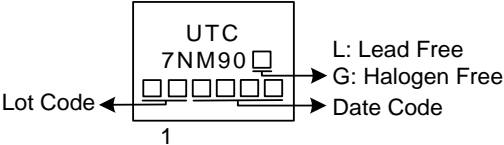

FLYING 汎翔國際有限公司
www.flying1688.com

■ **ABSOLUTE MAXIMUM RATINGS** ($T_C = 25^\circ\text{C}$, unless otherwise specified)

PARAMETER		SYMBOL	RATINGS	UNIT
Drain-Source Voltage		V_{DSS}	900	V
Gate-Source Voltage		V_{GSS}	± 30	V
Continuous Drain Current	Continuous	I_D	7	A
Pulsed Drain Current	Pulsed (Note 2)	I_{DM}	14	A
Single Pulsed Avalanche Energy	Single Pulsed (Note 3)	E_{AS}	51	mJ
Peak Diode Recovery dv/dt (Note 4)		dv/dt	2.04	V/ns
Power Dissipation	TO-220F1/TO-220F2	P_D	27	W
	TO-251/TO-251NS2		52	W
	TO-252			
Junction Temperature		T_J	+150	$^\circ\text{C}$
Storage Temperature		T_{STG}	-55 ~ +150	$^\circ\text{C}$

Notes: 1. Absolute maximum ratings are those values beyond which the device could be permanently damaged.

Absolute maximum ratings are stress ratings only and functional device operation is not implied.

2. Repetitive Rating: Pulse width limited by maximum junction temperature.

3. $L = 10\text{mH}$, $I_{AS} = 3.2\text{A}$, $V_{DD} = 50\text{V}$, $R_G = 25\Omega$, Starting $T_J = 25^\circ\text{C}$.

4. $I_{SD} \leq 7.0\text{A}$, $di/dt \leq 200\text{A}/\mu\text{s}$, $V_{DD} \leq BV_{DSS}$, Starting $T_J = 25^\circ\text{C}$.

■ **THERMAL DATA**

PARAMETER		SYMBOL	RATING	UNIT
Junction to Ambient	TO-220F1/TO-220F2	θ_{JA}	62.5	$^\circ\text{C}/\text{W}$
	TO-251/TO-251NS2		110	$^\circ\text{C}/\text{W}$
	TO-252			
Junction to Case	TO-220F1/TO-220F2	θ_{JC}	4.63	$^\circ\text{C}/\text{W}$
	TO-251/TO-251NS2		2.4	$^\circ\text{C}/\text{W}$
	TO-252			

Note: Device mounted on FR-4 substrate PC board, 2oz copper, with 1inch square copper plate.

ELECTRICAL CHARACTERISTICS ($T_J=25^{\circ}\text{C}$, unless otherwise specified)

PARAMETER	SYMBOL	TEST CONDITIONS	MIN	TYP	MAX	UNIT
OFF CHARACTERISTICS						
Drain-Source Breakdown Voltage	BV_{DSS}	$V_{GS}=0V, I_D=250\mu A$	900			V
Drain-Source Leakage Current	I_{DSS}	$V_{DS}=900V, V_{GS}=0V$			10	μA
Gate-Source Leakage Current	Forward	$V_{GS}=30V, V_{DS}=0V$			100	nA
	Reverse	$V_{GS}=-30V, V_{DS}=0V$			-100	nA
ON CHARACTERISTICS						
Gate Threshold Voltage	$V_{GS(TH)}$	$V_{DS}=V_{GS}, I_D=250\mu A$	2.5		4.5	V
Static Drain-Source On-State Resistance	$R_{DS(ON)}$	$V_{GS}=10V, I_D=3.5A$			1.4	Ω
DYNAMIC CHARACTERISTICS						
Input Capacitance	C_{ISS}	$V_{GS}=0V, V_{DS}=25V, f=1.0\text{MHz}$		670		pF
Output Capacitance	C_{OSS}			160		pF
Reverse Transfer Capacitance	C_{RSS}			1.7		pF
SWITCHING CHARACTERISTICS						
Total Gate Charge (Note 1)	Q_G	$V_{DS}=720V, V_{GS}=10V, I_D=7A$ $I_G=1\text{mA}$ (Note 1,2)		25		nC
Gate to Source Charge	Q_{GS}			6		nC
Gate to Drain Charge	Q_{GD}			7		nC
Turn-ON Delay Time (Note 1)	$t_{D(ON)}$	$V_{DD}=100V, V_{GS}=10V, I_D=7A$ $R_G=25\Omega$ (Note 1,2)		8		nS
Rise Time	t_R			18		nS
Turn-OFF Delay Time	$t_{D(OFF)}$			70		nS
Fall-Time	t_F			36		nS
SOURCE- DRAIN DIODE RATINGS AND CHARACTERISTICS						
Maximum Body-Diode Continuous Current	I_S				7	A
Maximum Body-Diode Pulsed Current	I_{SM}				14	A
Drain-Source Diode Forward Voltage (Note 1)	V_{SD}	$I_S=7A, V_{GS}=0V$			1.4	V
Body Diode Reverse Recovery Time (Note 1)	t_{rr}	$I_S=7A, V_{GS}=0V,$ $di_f/dt=100A/\mu s$		500		nS
Body Diode Reverse Recovery Charge	Q_{rr}			6.6		μC

Notes: 1. Pulse Test : Pulse width $\leq 300\mu s$, Duty cycle $\leq 2\%$.

2. Essentially independent of operating ambient temperature.

■ TEST CIRCUITS AND WAVEFORMS

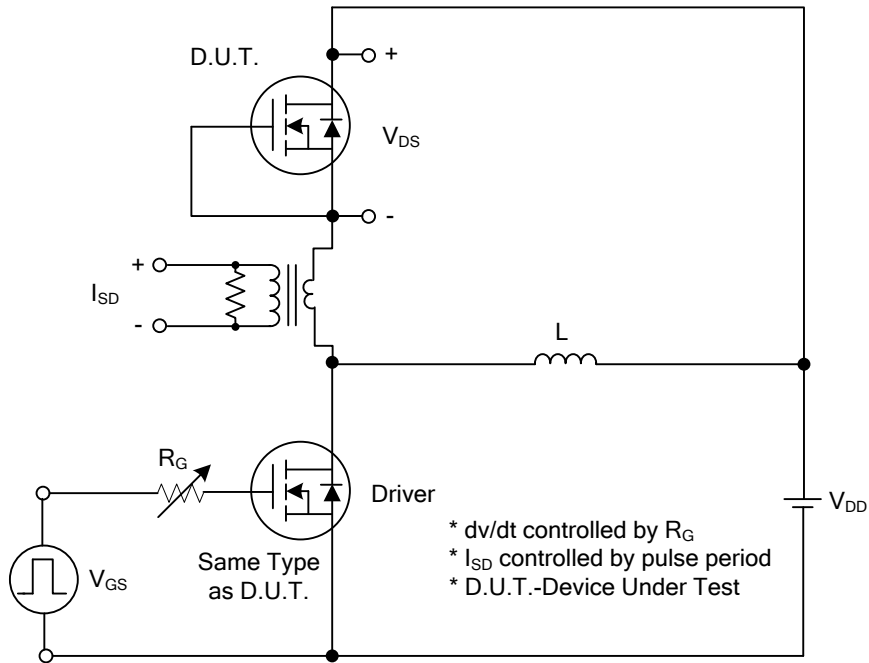

Peak Diode Recovery dv/dt Test Circuit

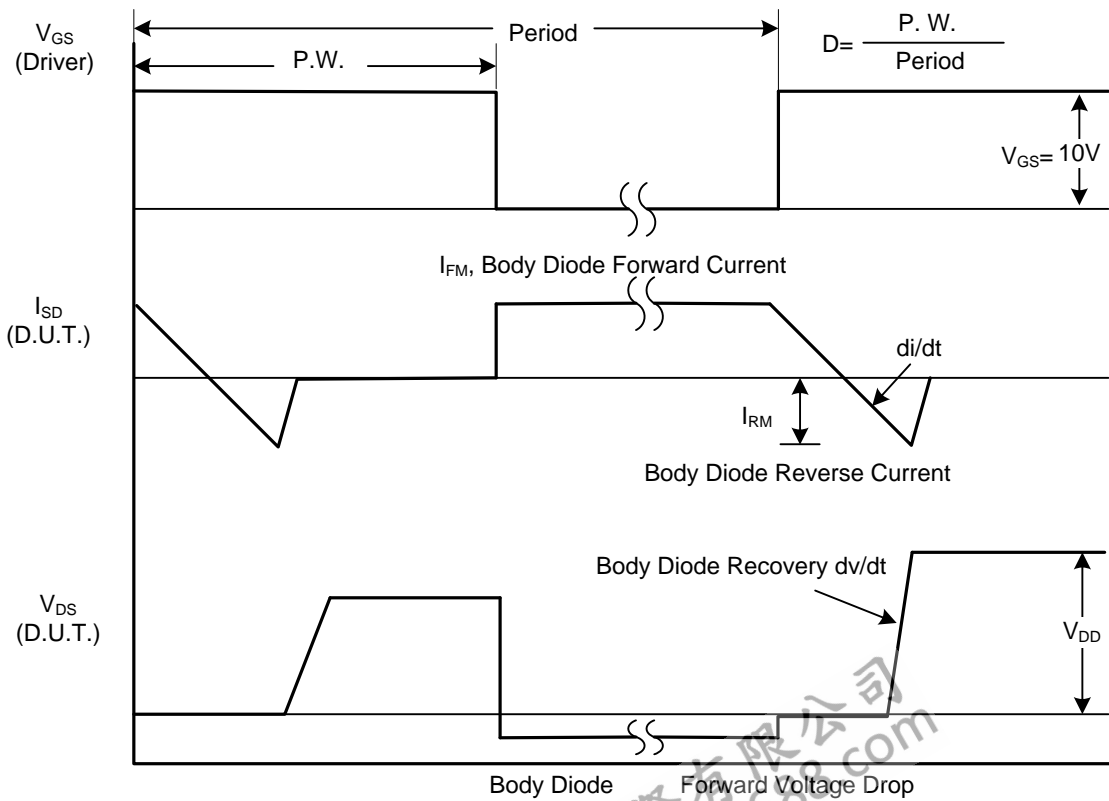

Peak Diode Recovery dv/dt Waveforms

■ TEST CIRCUITS AND WAVEFORMS

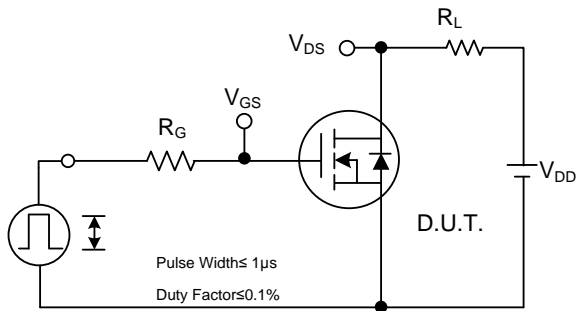

Switching Test Circuit

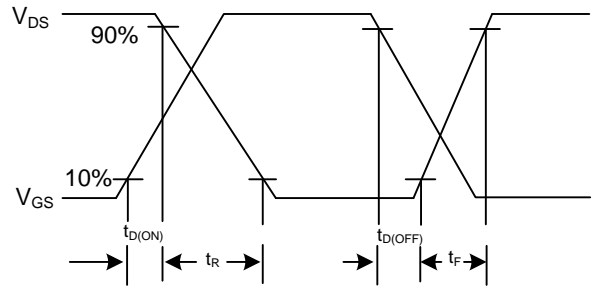

Switching Waveforms

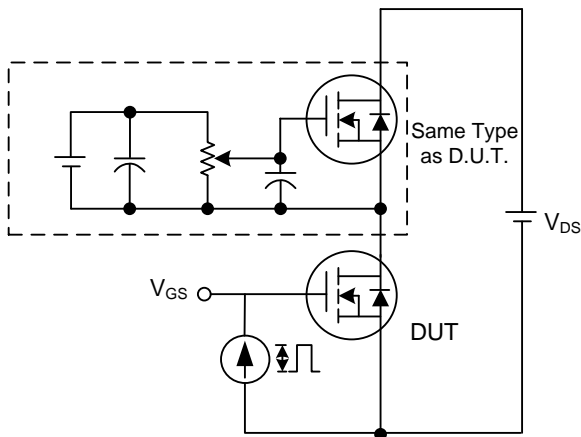

Gate Charge Test Circuit

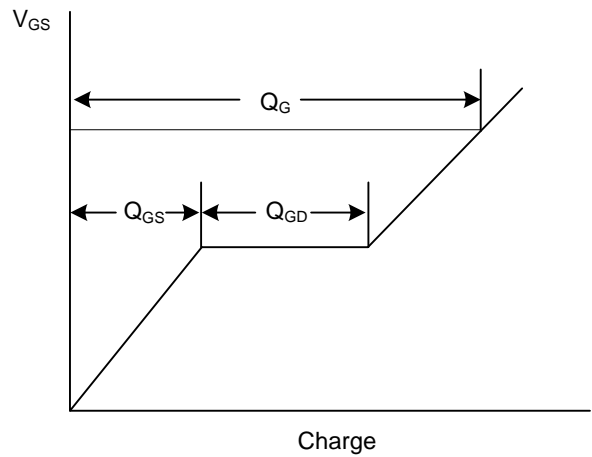

Gate Charge Waveform

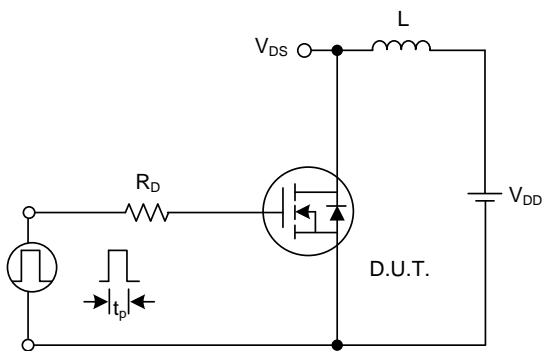

Unclamped Inductive Switching Test Circuit

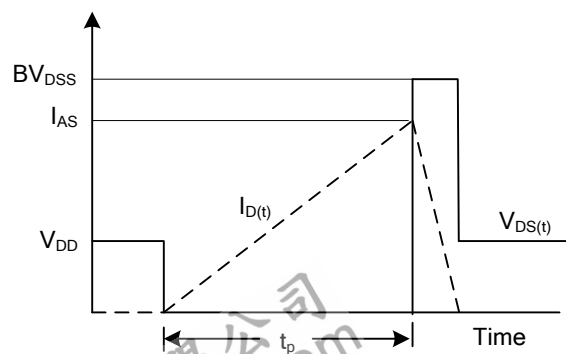

Unclamped Inductive Switching Waveforms

TYPICAL CHARACTERISTICS

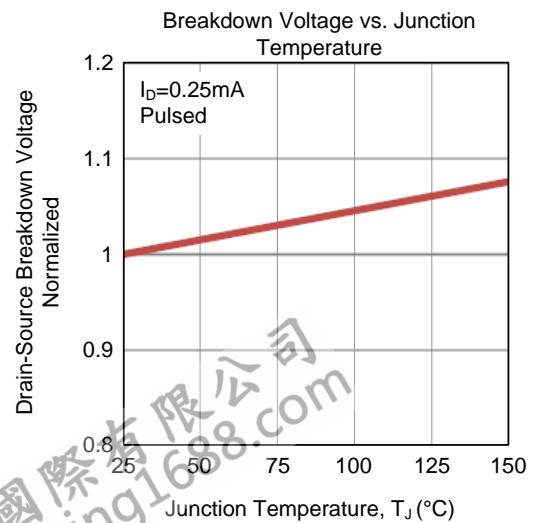
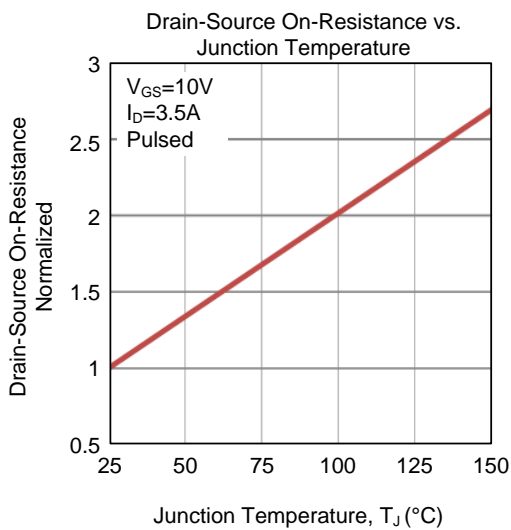
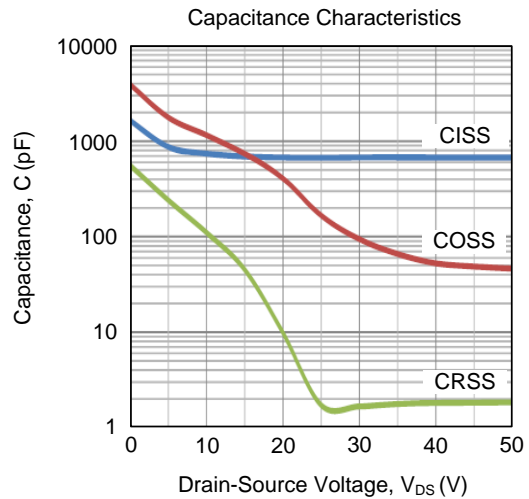
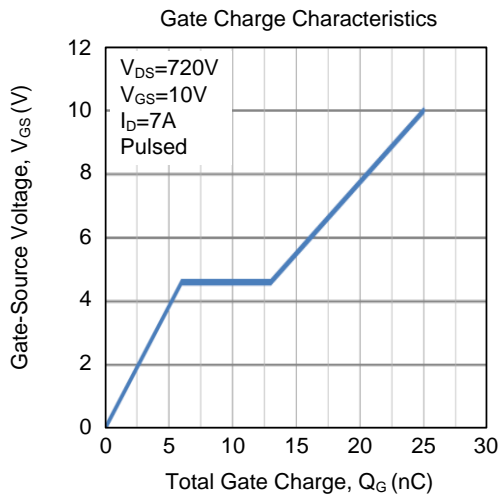
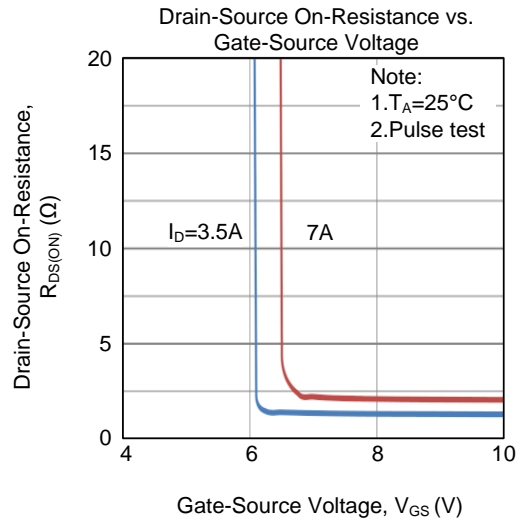
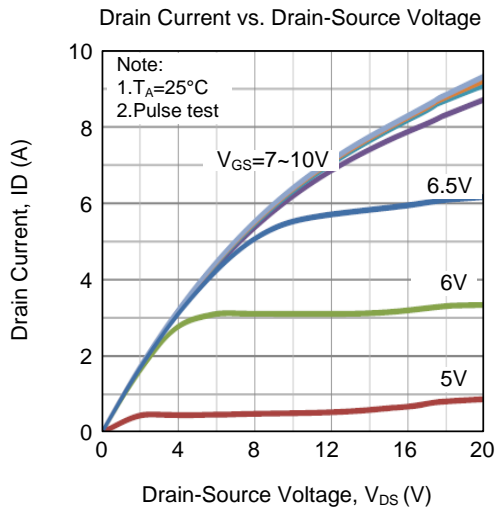

■ TYPICAL CHARACTERISTICS (Cont.)

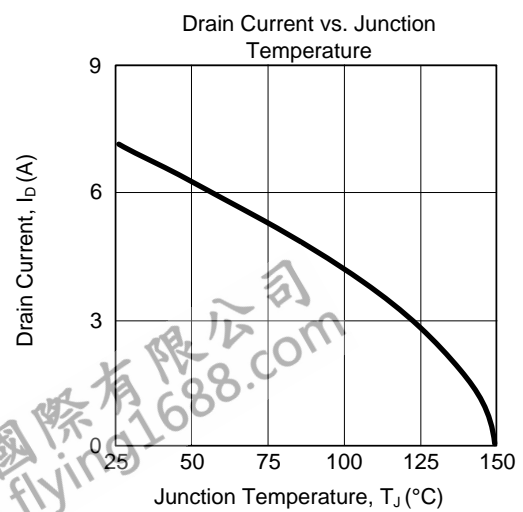
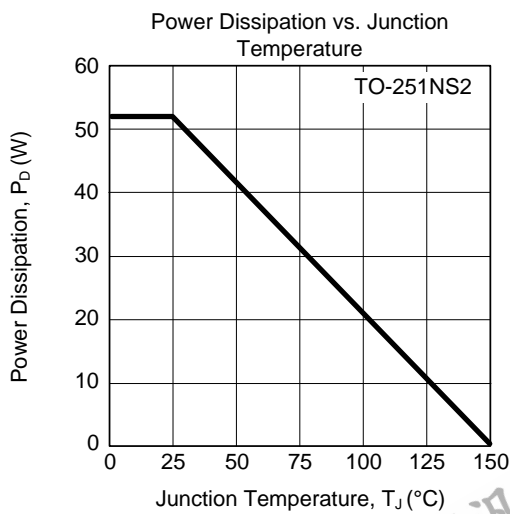
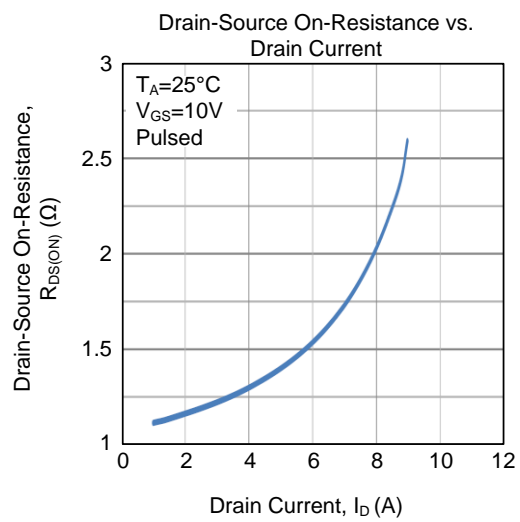
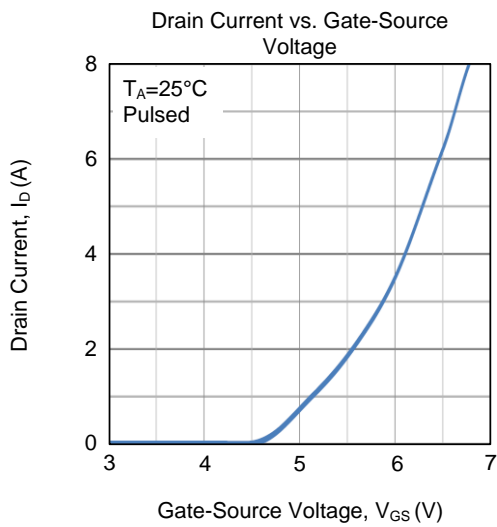
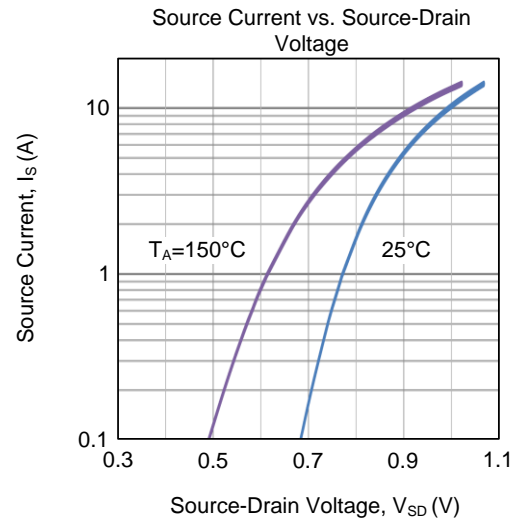
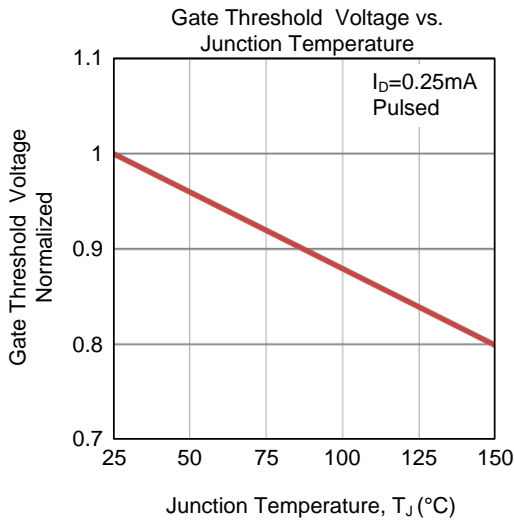

■ TYPICAL CHARACTERISTICS (Cont.)

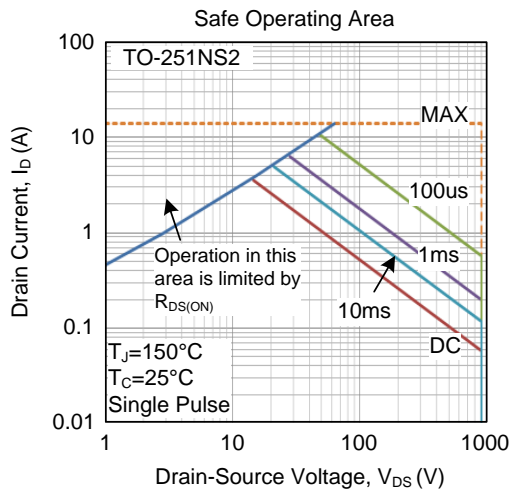

UTC assumes no responsibility for equipment failures that result from using products at values that exceed, even momentarily, rated values (such as maximum ratings, operating condition ranges, or other parameters) listed in products specifications of any and all UTC products described or contained herein. UTC products are not designed for use in life support appliances, devices or systems where malfunction of these products can be reasonably expected to result in personal injury. Reproduction in whole or in part is prohibited without the prior written consent of the copyright owner. UTC reserves the right to make changes to information published in this document, including without limitation specifications and product descriptions, at any time and without notice. This document supersedes and replaces all information supplied prior to the publication hereof.