



8N65-MH

Power MOSFET

8A, 650V N-CHANNEL POWER MOSFET

DESCRIPTION

The UTC 8N65-MH is a high voltage power MOSFET combines advanced trench MOSFET designed to have better characteristics, such as fast switching time, low gate charge, low on-state resistance and high rugged avalanche characteristics. This power MOSFET is usually used in high speed switching applications of switching power supplies and adaptors.

FEATURES

- * $R_{DS(ON)} \leq 1.2 \Omega @ V_{GS}=10V, I_D=4.0A$
- * Fast switching capability
- * Avalanche energy tested
- * Improved dv/dt capability, high ruggedness

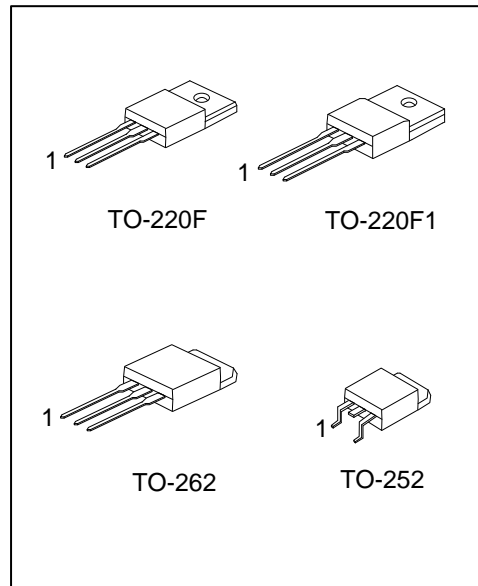

SYMBOL

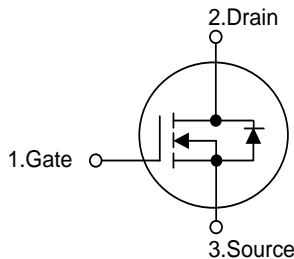

ORDERING INFORMATION

Ordering Number		Package	Pin Assignment			Packing
Lead Free	Halogen Free		1	2	3	
8N65L-TF1-T	8N65G-TF1-T	TO-220F1	G	D	S	Tube
8N65L-TF3-T	8N65G-TF3-T	TO-220F	G	D	S	Tube
8N65L-TN3-R	8N65G-TN3-R	TO-252	G	D	S	Tape Reel
8N65L-T2Q-T	8N65G-T2Q-T	TO-262	G	D	S	Tube

Note: Pin Assignment: G: Gate D: Drain S: Source

<p>8N65G-TF1-T</p> <p>(1)Packing Type (2)Package Type (3)Green Package</p>	<p>(1) T: Tube, R: Tape Reel (2) TF1: TO-220F1, TF3: TO-220F, TN3: TO-252 T2Q: TO-262 (3) G: Halogen Free and Lead Free, L: Lead Free</p>
--	---

MARKING

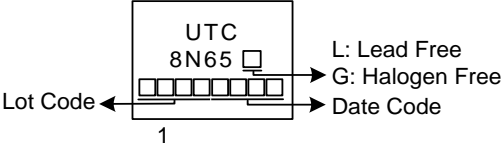

FLYING 汎翔國際有限公司
www.flying1688.com

■ ABSOLUTE MAXIMUM RATINGS (T_c=25°C, unless otherwise specified)

PARAMETER		SYMBOL	RATINGS	UNIT
Drain-Source Voltage		V _{DSS}	650	V
Gate-Source Voltage		V _{GSS}	±30	V
Continuous Drain Current		I _D	8	A
Pulsed Drain Current (Note 2)		I _{DM}	16	A
Avalanche Energy	Single Pulsed (Note 3)	E _{AS}	320	mJ
Peak Diode Recovery dv/dt (Note 4)		dv/dt	2.1	V/ns
Power Dissipation	TO-220F/TO-220F1	P _D	36	W
	TO-252		50	W
	TO-262		130	W
Junction Temperature		T _J	+150	°C
Storage Temperature		T _{STG}	-55 ~ +150	°C

Notes: 1. Absolute maximum ratings are those values beyond which the device could be permanently damaged.

Absolute maximum ratings are stress ratings only and functional device operation is not implied.

2. Repetitive Rating: Pulse width limited by maximum junction temperature.

3. L = 10mH, I_{AS} = 8.0A, V_{DD} = 50V, R_G = 25 Ω, Starting T_J = 25°C

4. I_{SD} ≤ 8.0A, di/dt ≤ 200A/μs, V_{DD} ≤ BV_{DSS}, Starting T_J = 25°C

■ THERMAL DATA

PARAMETER		SYMBOL	RATING	UNIT
Junction to Ambient	TO-220F/TO-220F1	θ _{JA}	62.5	°C/W
	TO-262		100	°C/W
	TO-252			
Junction to Case	TO-220F/TO-220F1	θ _{JC}	3.47	°C/W
	TO-252		2.5 (Note)	°C/W
	TO-262		0.96	°C/W

Note: Device mounted on FR-4 substrate PC board, 2oz copper, with 1inch square copper plate.

■ **ELECTRICAL CHARACTERISTICS** ($T_J=25^\circ\text{C}$, unless otherwise specified)

PARAMETER	SYMBOL	TEST CONDITIONS	MIN	TYP	MAX	UNIT
OFF CHARACTERISTICS						
Drain-Source Breakdown Voltage	BV_{DSS}	$V_{GS}=0V, I_D=250\mu A$	650			V
Drain-Source Leakage Current	I_{DSS}	$V_{DS}=650V, V_{GS}=0V$			10	μA
Gate- Source Leakage Current	Forward	$V_{GS}=30V, V_{DS}=0V$			100	nA
	Reverse		$V_{GS}=-30V, V_{DS}=0V$			-100
ON CHARACTERISTICS						
Gate Threshold Voltage	$V_{GS(TH)}$	$V_{DS}=V_{GS}, I_D=250\mu A$	2.0		4.0	V
Static Drain-Source On-State Resistance	$R_{DS(ON)}$	$V_{GS}=10V, I_D=4.0A$			1.2	Ω
DYNAMIC CHARACTERISTICS						
Input Capacitance	C_{ISS}	$V_{DS}=25V, V_{GS}=0V, f=1.0\text{MHz}$		1070		pF
Output Capacitance	C_{OSS}			114		pF
Reverse Transfer Capacitance	C_{RSS}			15.5		pF
SWITCHING CHARACTERISTICS						
Total Gate Charge (Note 1)	Q_G	$V_{DS}=520V, V_{GS}=10V, I_D=8.0A$ $I_G=1\text{mA}$ (Note 1, 2)		29		nC
Gate-Source Charge	Q_{GS}			5.5		nC
Gate-Drain Charge	Q_{GD}			9.2		nC
Turn-On Delay Time (Note 1)	$t_{D(ON)}$	$V_{DS}=100V, V_{GS}=10V,$ $I_D=8.0A, R_G=25\Omega$ (Note 1, 2)		12		ns
Turn-On Rise Time	t_R			23		ns
Turn-Off Delay Time	$t_{D(OFF)}$			105		ns
Turn-Off Fall Time	t_F			43		ns
DRAIN-SOURCE DIODE CHARACTERISTICS AND MAXIMUM RATINGS						
Maximum Body-Diode Continuous Current	I_S				8	A
Maximum Body-Diode Pulsed Current	I_{SM}				16	A
Drain-Source Diode Forward Voltage (Note 1)	V_{SD}	$I_S=8.0A, V_{GS}=0V$			1.4	V
Reverse Recovery Time (Note 1)	t_{rr}	$I_S=8.0A, V_{GS}=0V$ $di/dt=100A/\mu s$		384		ns
Reverse Recovery Charge	Q_{rr}				3.4	

Notes: 1. Pulse Test: Pulse width $\leq 300\mu s$, Duty cycle $\leq 2\%$.

2. Essentially independent of operating temperature.

■ TEST CIRCUITS AND WAVEFORMS

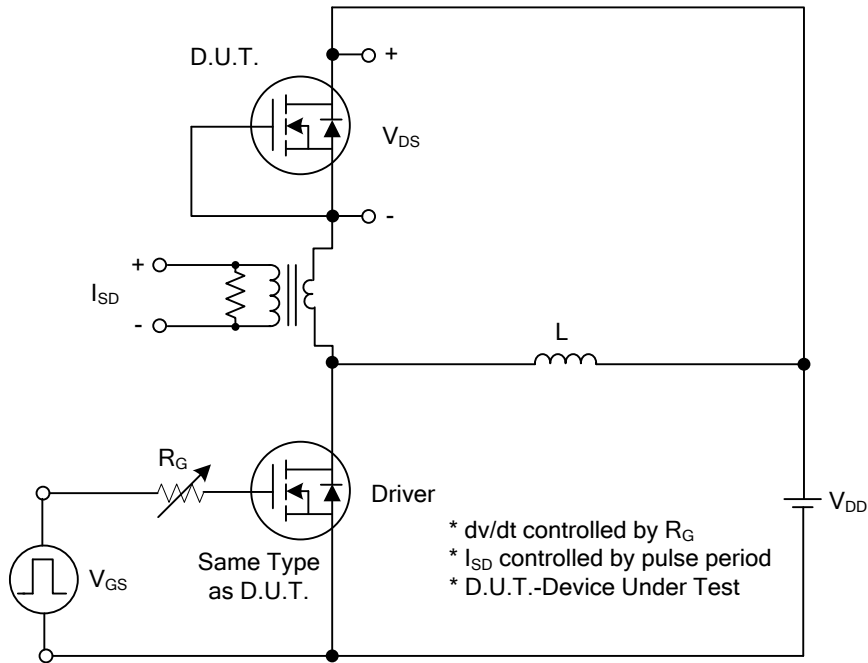

Peak Diode Recovery dv/dt Test Circuit

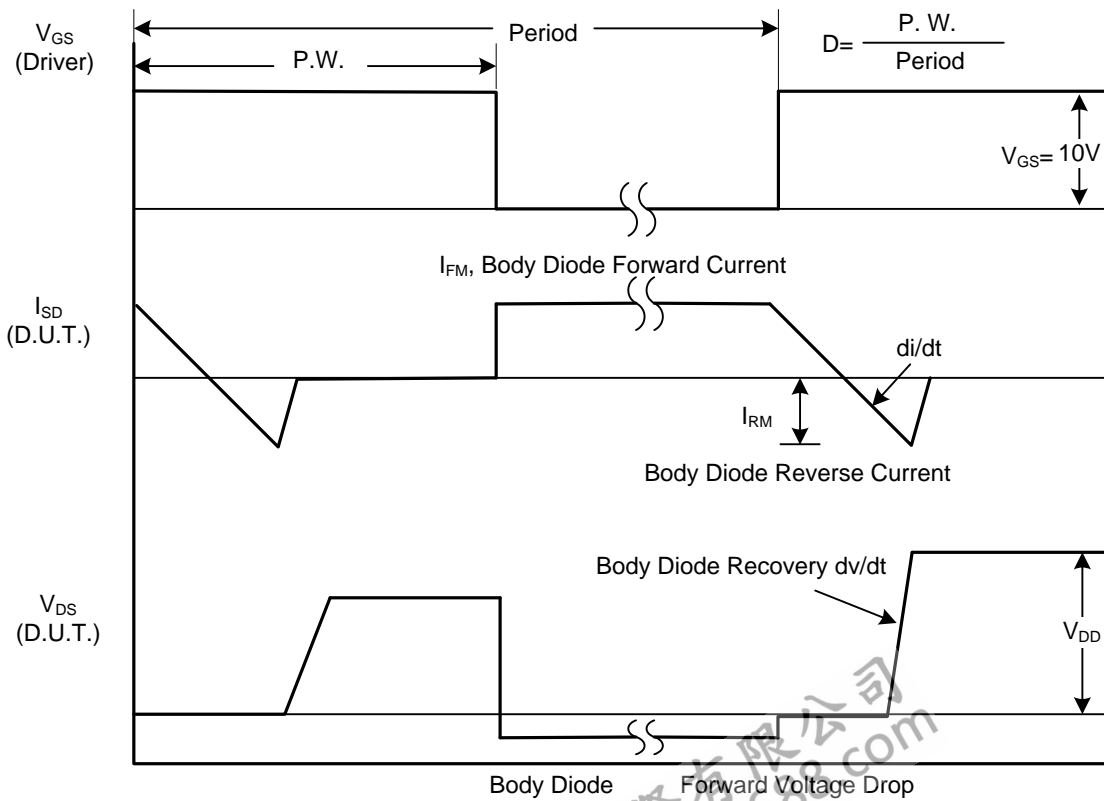

Peak Diode Recovery dv/dt Waveforms

TEST CIRCUITS AND WAVEFORMS

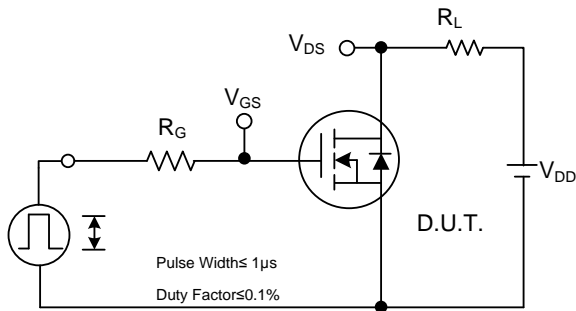

Switching Test Circuit

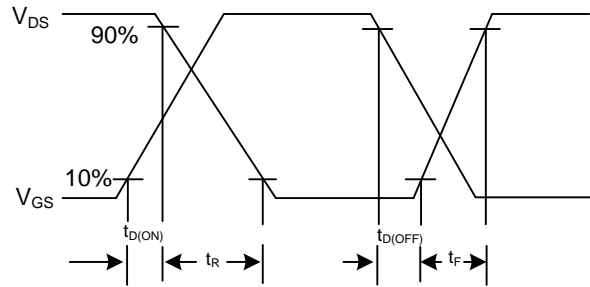

Switching Waveforms

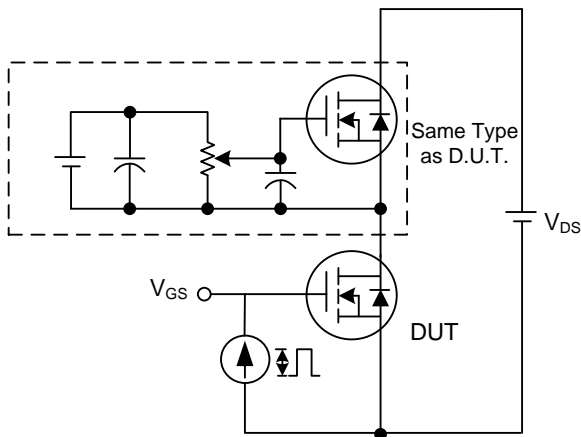

Gate Charge Test Circuit

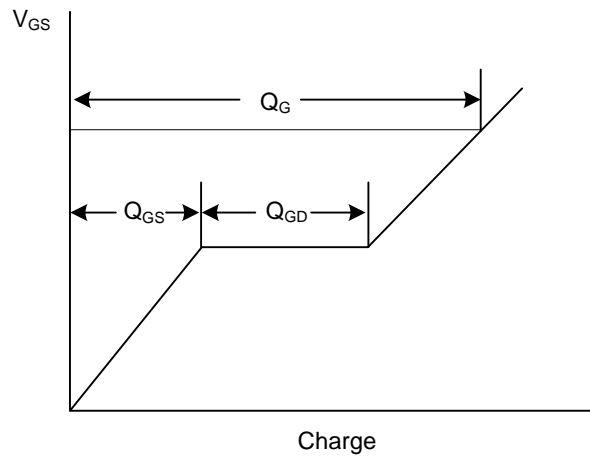

Gate Charge Waveform

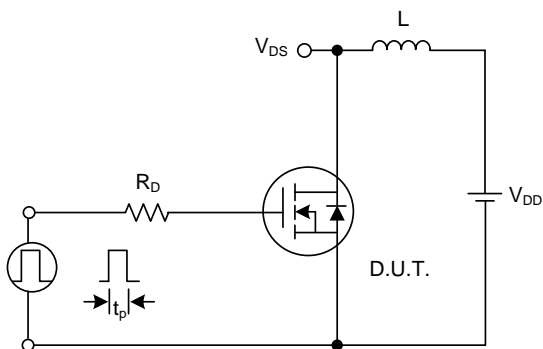

Unclamped Inductive Switching Test Circuit

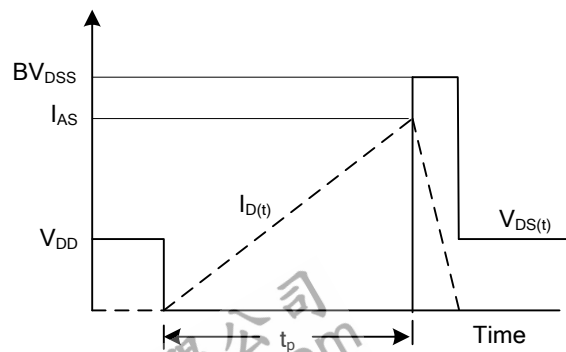

Unclamped Inductive Switching Waveforms

TYPICAL CHARACTERISTICS

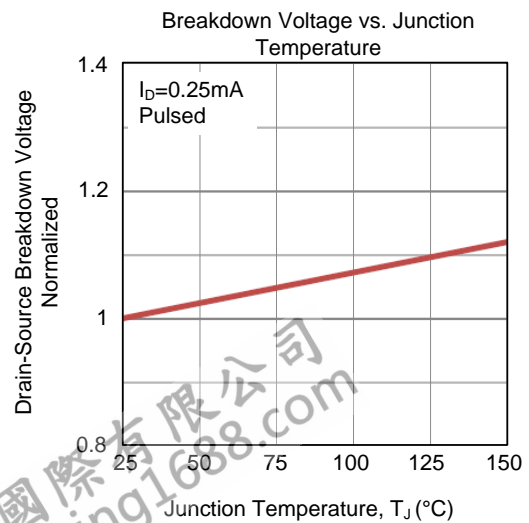
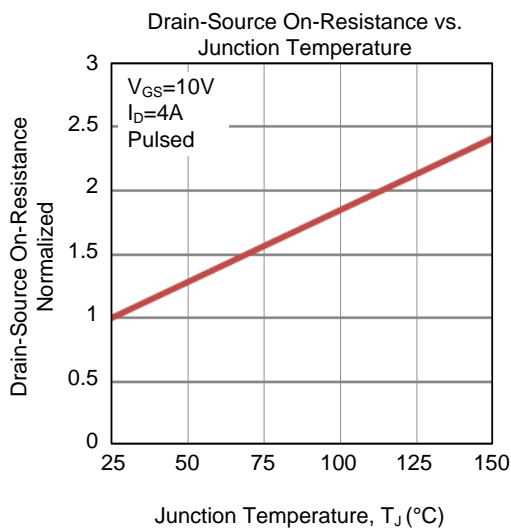
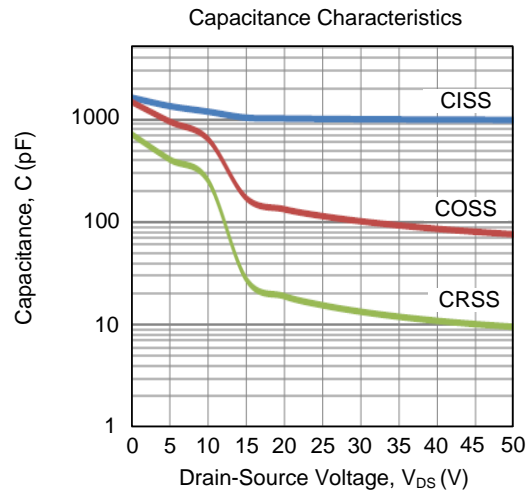
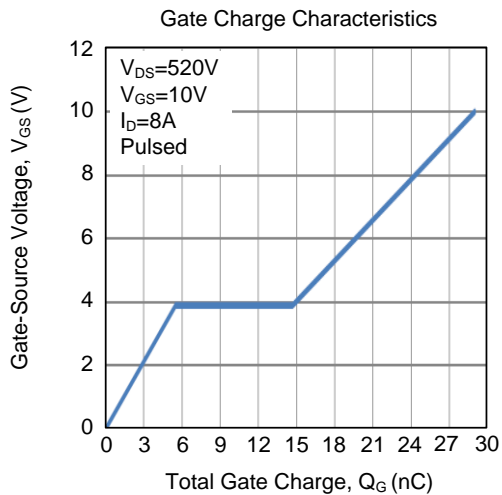
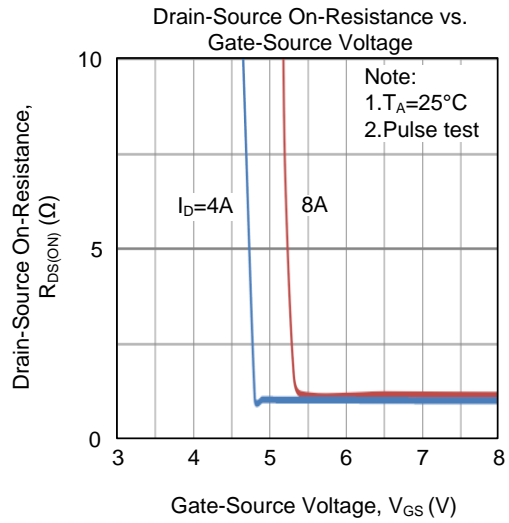
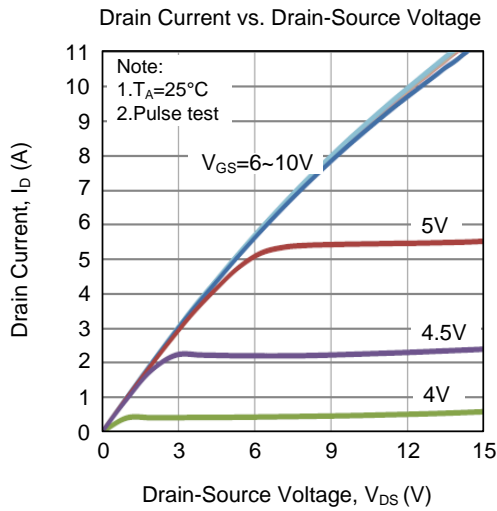

■ TYPICAL CHARACTERISTICS (Cont.)

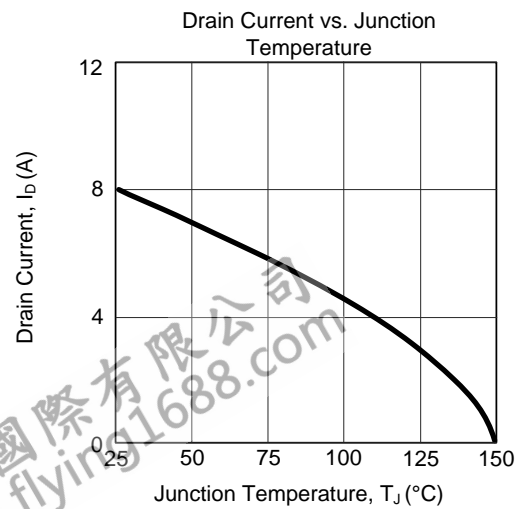
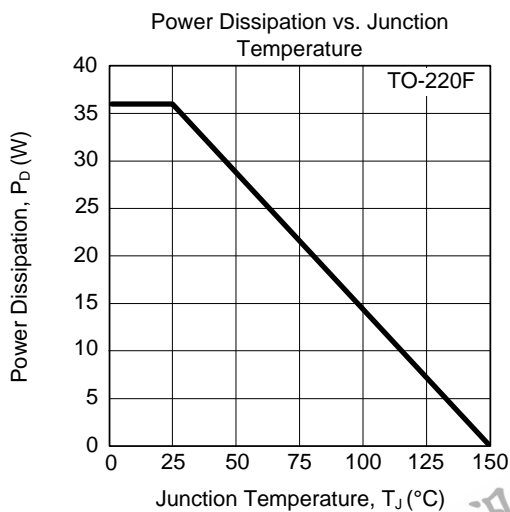
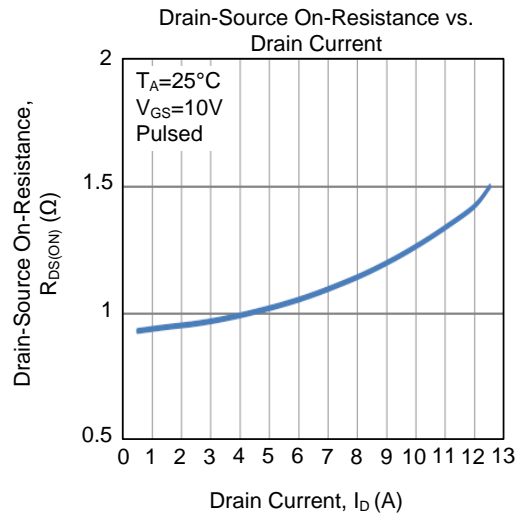
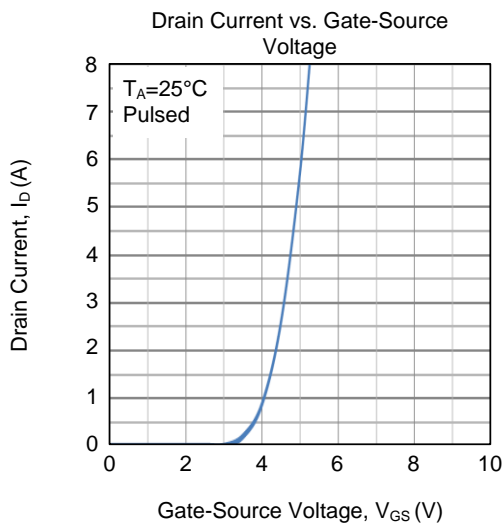
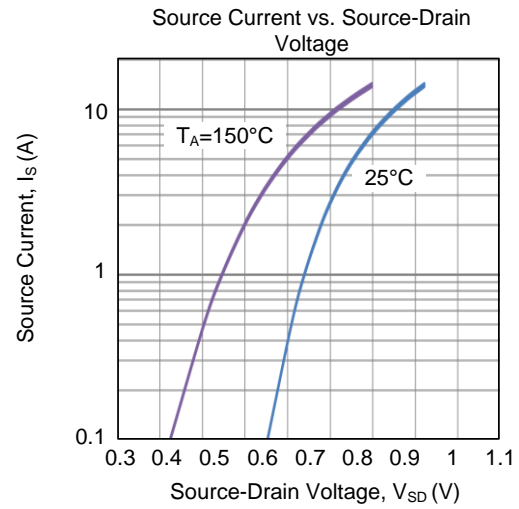
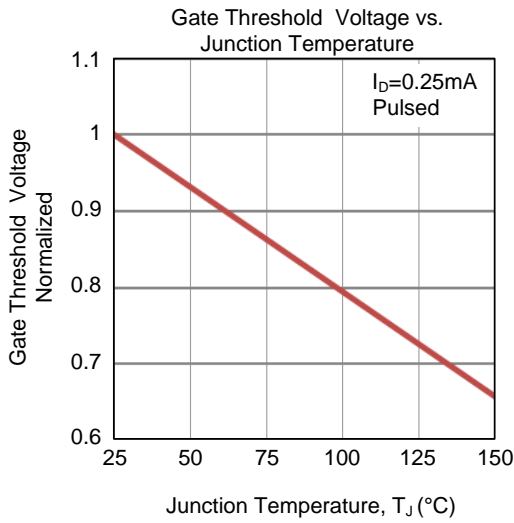

■ TYPICAL CHARACTERISTICS (Cont.)

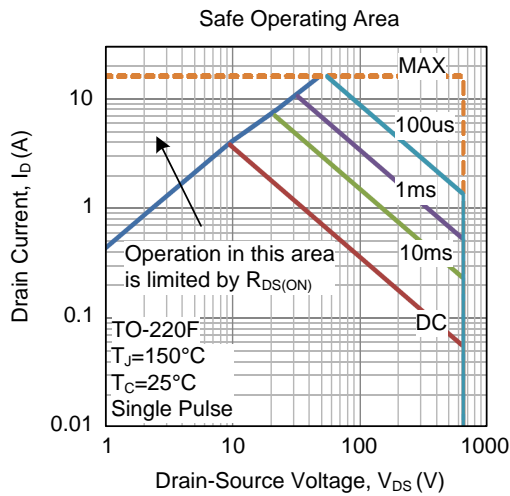

UTC assumes no responsibility for equipment failures that result from using products at values that exceed, even momentarily, rated values (such as maximum ratings, operating condition ranges, or other parameters) listed in products specifications of any and all UTC products described or contained herein. UTC products are not designed for use in life support appliances, devices or systems where malfunction of these products can be reasonably expected to result in personal injury. Reproduction in whole or in part is prohibited without the prior written consent of the copyright owner. UTC reserves the right to make changes to information published in this document, including without limitation specifications and product descriptions, at any time and without notice. This document supersedes and replaces all information supplied prior to the publication hereof.