



9NM70-S

Power MOSFET

9A, 700V N-CHANNEL SUPER-JUNCTION MOSFET

DESCRIPTION

The UTC 9NM70-S is a Super Junction MOSFET Structure and is designed to have better characteristics, such as fast switching time, low gate charge, low on-state resistance and a high rugged avalanche characteristics. This power MOSFET is usually used at AC-DC converters for power applications.

FEATURES

- * $R_{DS(ON)} \leq 0.65 \Omega @ V_{GS}=10V, I_D=1.5A$
- * High switching Speed
- * 100% avalanche tested
- * Improved dv/dt capability

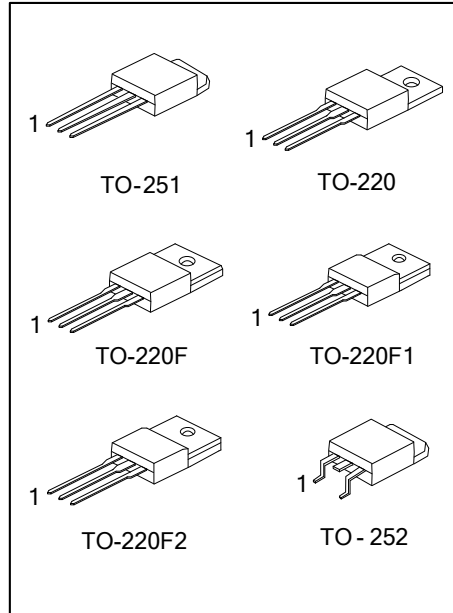

SYMBOL

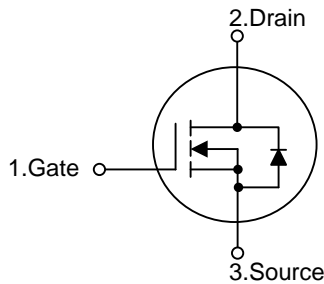

ORDERING INFORMATION

Ordering Number		Package	Pin Assignment			Packing
Lead Free	Halogen Free		1	2	3	
9NM70L-TA3-T	9NM70G-TA3-T	TO-220	G	D	S	Tube
9NM70L-TF1-T	9NM70G-TF1-T	TO-220F1	G	D	S	Tube
9NM70L-TF2-T	9NM70G-TF2-T	TO-220F2	G	D	S	Tube
9NM70L-TF3-T	9NM70G-TF3-T	TO-220F	G	D	S	Tube
9NM70L-TM3-T	9NM70G-TM3-T	TO-251	G	D	S	Tube
9NM70L-TN3-R	9NM70G-TN3-R	TO-252	G	D	S	Tape Reel

Note: Pin Assignment: G: Gate D: Drain S: Source

<p>9NM70G-TA3-T</p> <p>(1) Packing Type</p> <p>(2) Package Type</p> <p>(3) Green Package</p>	<p>(1) T: Tube, R: Tape Reel</p> <p>(2) TA3: TO-220, TF3: TO-220F, TF1: TO-220F1, TF2: TO-220F2, TM3: TO-251, TN3: TO-252</p> <p>(3) G: Halogen Free and Lead Free, L: Lead Free</p>
--	--

MARKING

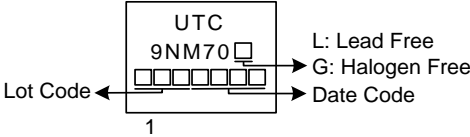

FLYING 汎翔國際有限公司
www.flying1688.com

■ ABSOLUTE MAXIMUM RATINGS (T_C = 25°C, unless otherwise specified)

PARAMETER		SYMBOL	RATINGS	UNIT
Drain-Source Voltage		V _{DSS}	700	V
Gate-Source Voltage		V _{GSS}	±30	V
Drain Current	Continuous	I _D	9	A
	Pulsed (Note 2)	I _{DM}	36	A
Avalanche Current		I _{AR}	2.2	A
Avalanche Energy	Single Pulsed (Note 3)	E _{AS}	242	mJ
Peak Diode Recovery dv/dt (Note 4)		dv/dt	4.55	V/ns
Power Dissipation	TO-220	P _D	79	W
	TO-220F/TO-220F1		30	W
	TO-220F2			
	TO-251/TO-252		57	W
Junction Temperature		T _J	+150	°C
Storage Temperature		T _{STG}	-55 ~ +150	°C

Notes: 1. Absolute maximum ratings are those values beyond which the device could be permanently damaged.

Absolute maximum ratings are stress ratings only and functional device operation is not implied.

2. Repetitive Rating: Pulse width limited by maximum junction temperature.

3. L=100mH, I_{AS}=2.2A, V_{DD}=50V, R_G=0 Ω, Starting T_J=25°C

4. I_{SD} ≤ 9.0A, di/dt ≤ 200A/μs, V_{DD} ≤ BV_{DSS}, Starting T_J=25°C

■ THERMAL DATA

PARAMETER		SYMBOL	RATING	UNIT
Junction to Ambient	TO-220/TO-220F	θ _{JA}	62.5	°C/W
	TO-220F1/TO-220F2			
	TO-251/TO-252			
Junction to Case	TO-220	θ _{JC}	1.58	°C/W
	TO-220F/TO-220F1		4.17	
	TO-220F2			
	TO-251/TO-252		2.19 (Note)	

Note: Device mounted on FR-4 substrate PC board, 2oz copper, with 1inch square copper plate.

■ ELECTRICAL CHARACTERISTICS (T_J=25°C, unless otherwise specified)

PARAMETER	SYMBOL	TEST CONDITIONS	MIN	TYP	MAX	UNIT
OFF CHARACTERISTICS						
Drain-Source Breakdown Voltage	B _V DSS	I _D =1mA, V _{GS} =0V	700			V
Drain-Source Leakage Current	I _{DSS}	V _{DS} =700V, V _{GS} =0V			10	μA
Gate- Source Leakage Current	Forward	V _{GS} =+30V			+100	nA
	Reverse	V _{GS} =-30V			-100	nA
ON CHARACTERISTICS						
Gate Threshold Voltage	V _{GS(TH)}	V _{DS} =V _{GS} , I _D =250μA	2.5		4.5	V
Static Drain-Source On-State Resistance	R _{DS(ON)}	V _{GS} =10V, I _D =1.5A			0.65	Ω
DYNAMIC PARAMETERS						
Input Capacitance	C _{ISS}	V _{GS} =0V, V _{DS} =25V, f=1.0MHz		560		pF
Output Capacitance	C _{OSS}			350		pF
Reverse Transfer Capacitance	C _{RSS}			35		pF
SWITCHING PARAMETERS						
Total Gate Charge (Note 1)	Q _G	V _{DS} =560V, V _{GS} =10V, I _D =9A, I _G =1mA (Note 1, 2)		21		nC
Gate to Source Charge	Q _{GS}			4		nC
Gate to Drain Charge	Q _{GD}			7		nC
Turn-ON Delay Time (Note 1)	t _{D(ON)}	V _{DD} =100V, V _{GS} =10V, I _D =9A, R _G =25Ω (Note 1, 2)		9		ns
Rise Time	t _R			20		ns
Turn-OFF Delay Time	t _{D(OFF)}			60		ns
Fall-Time	t _F			45		ns
SOURCE- DRAIN DIODE RATINGS AND CHARACTERISTICS						
Maximum Body-Diode Continuous Current	I _S				9	A
Maximum Body-Diode Pulsed Current	I _{SM}				36	A
Drain-Source Diode Forward Voltage (Note 1)	V _{SD}	I _S =9.0A, V _{GS} =0V			1.4	V
Body Diode Reverse Recovery Time (Note 1)	t _{rr}	I _S =9.0A, V _{GS} =0V,		340		ns
Body Diode Reverse Recovery Charge	Q _{rr}	dI _F /dt=100A/μs		4.27		μC

Notes: 1. Pulse Test: Pulse width ≤ 300μs, Duty cycle ≤ 2%.

2. Essentially independent of operating temperature.

TEST CIRCUITS AND WAVEFORMS

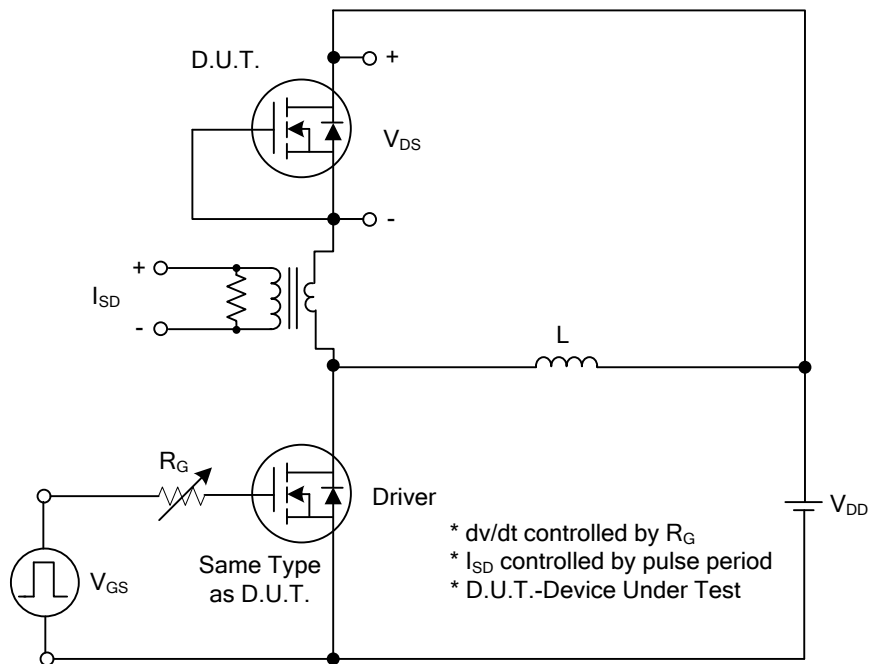

Peak Diode Recovery dv/dt Test Circuit

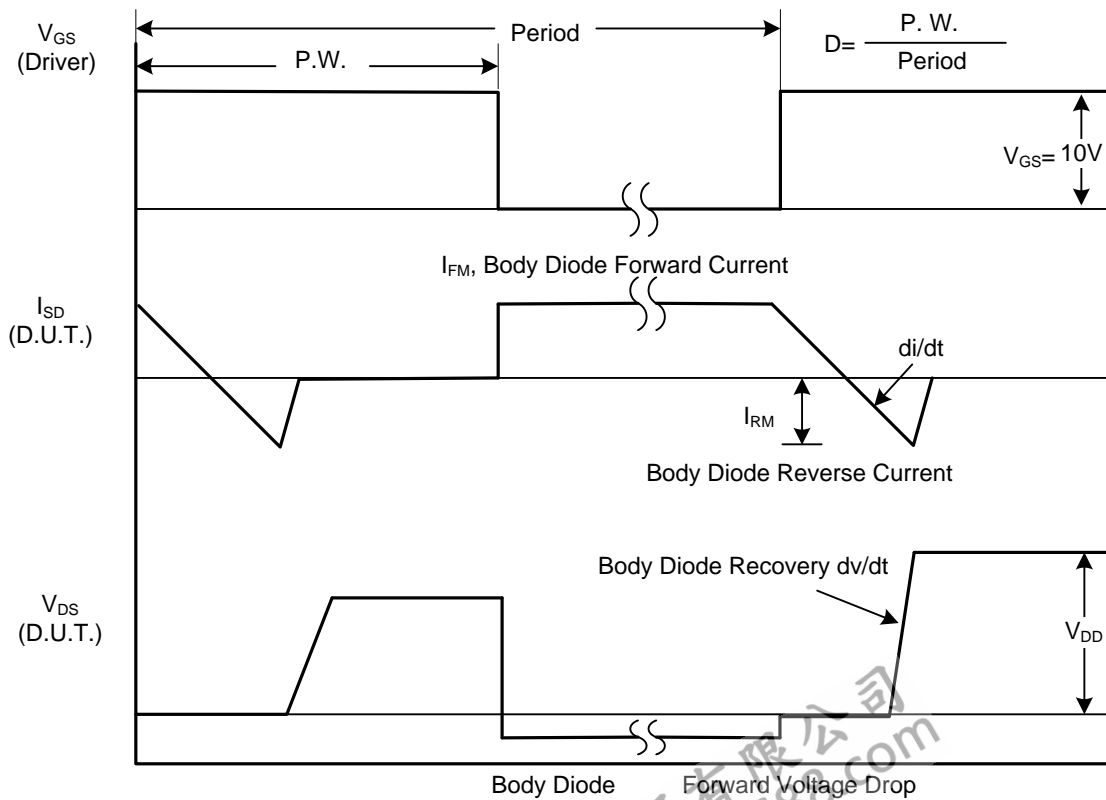

Peak Diode Recovery dv/dt Waveforms

TEST CIRCUITS AND WAVEFORMS

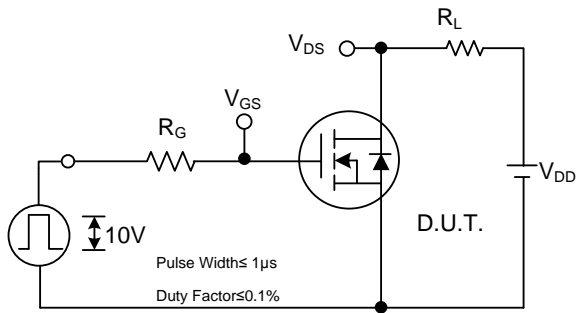

Switching Test Circuit

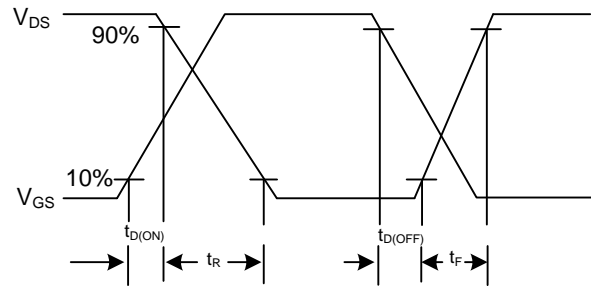

Switching Waveforms

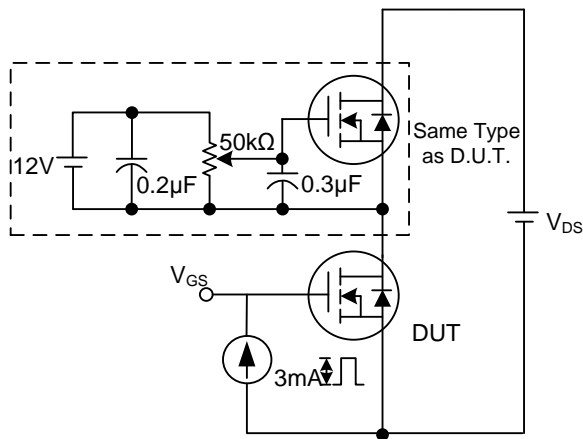

Gate Charge Test Circuit

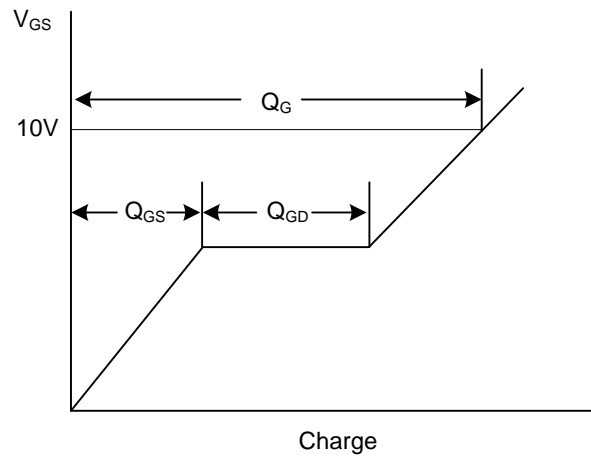

Gate Charge Waveform

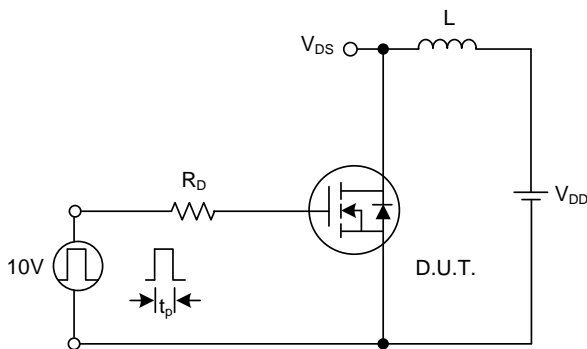

Unclamped Inductive Switching Test Circuit

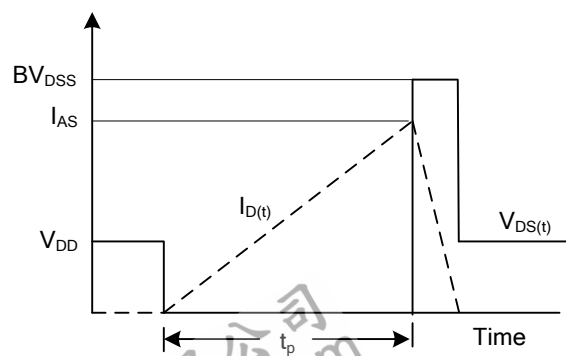

Unclamped Inductive Switching Waveforms

TYPICAL CHARACTERISTICS

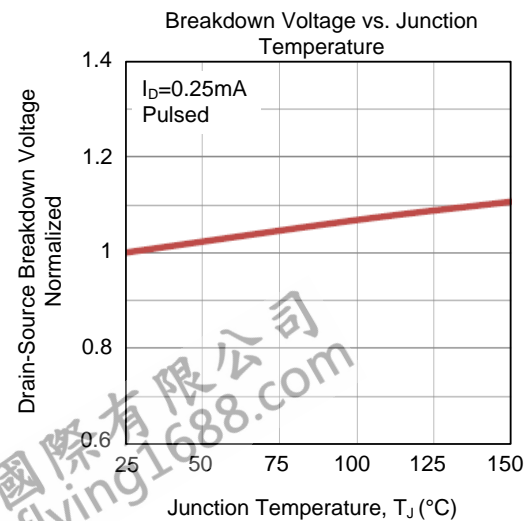
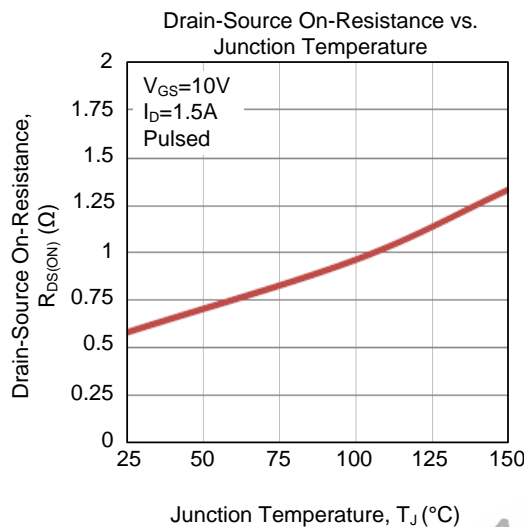
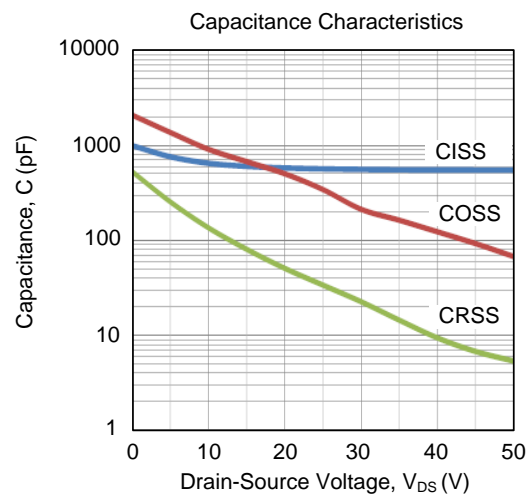
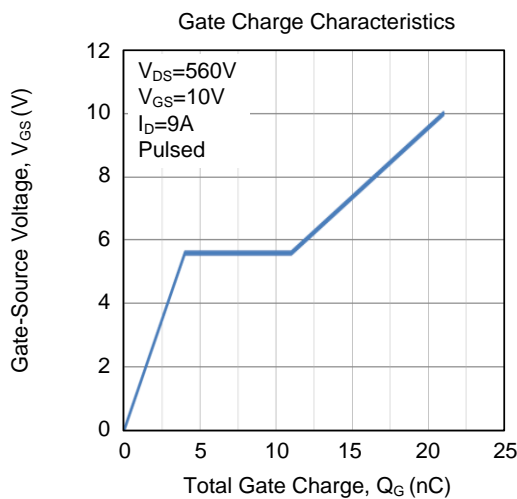
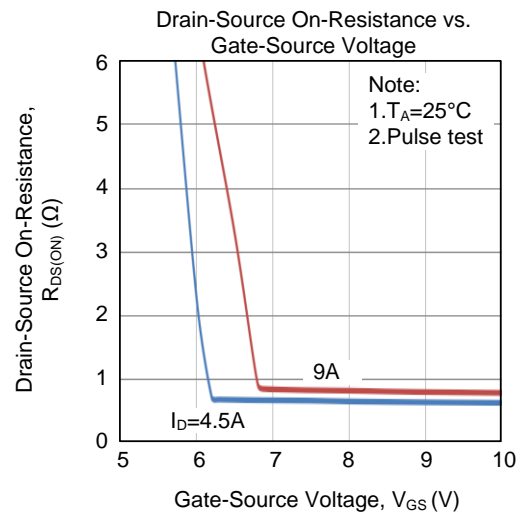
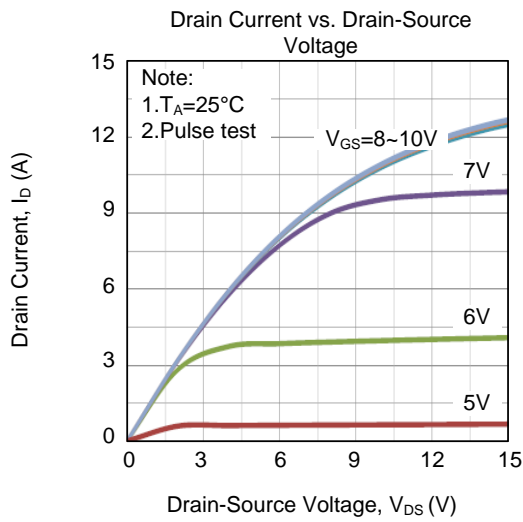

■ TYPICAL CHARACTERISTICS (Cont.)

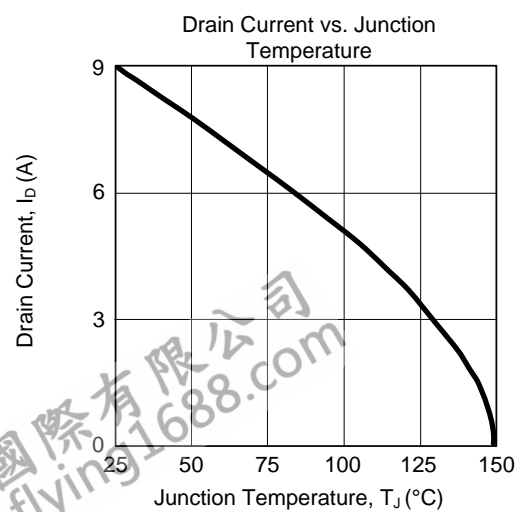
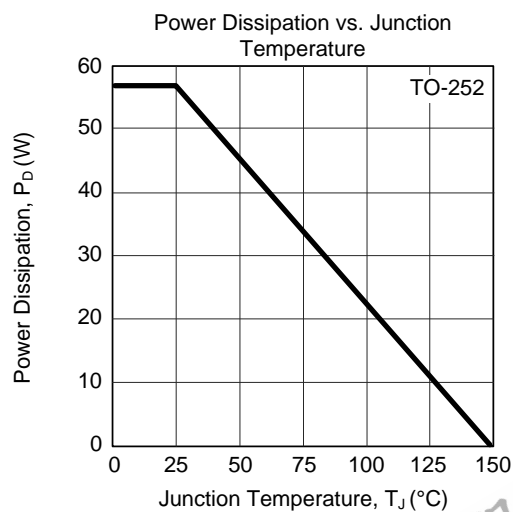
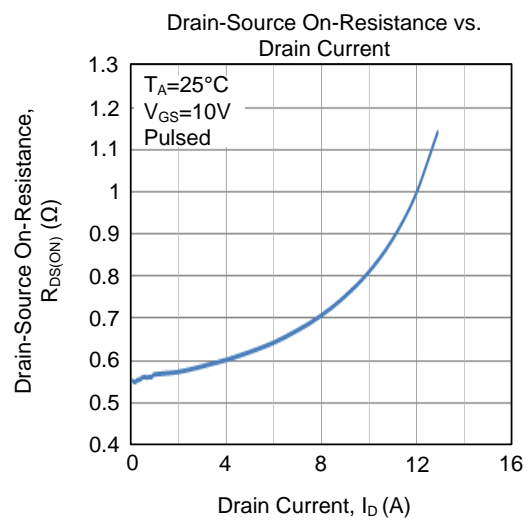
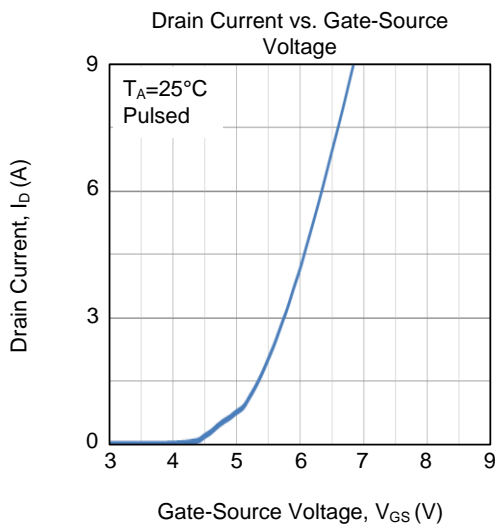
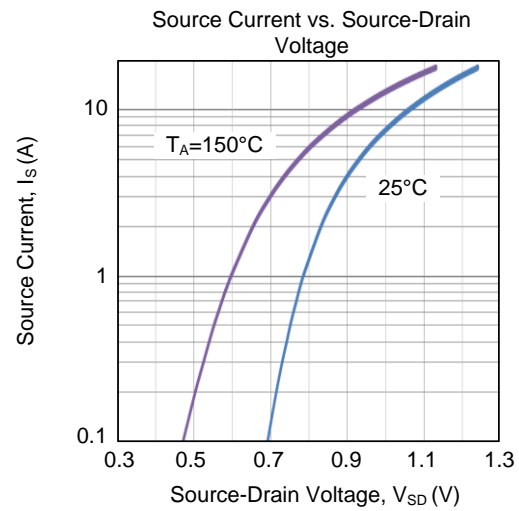
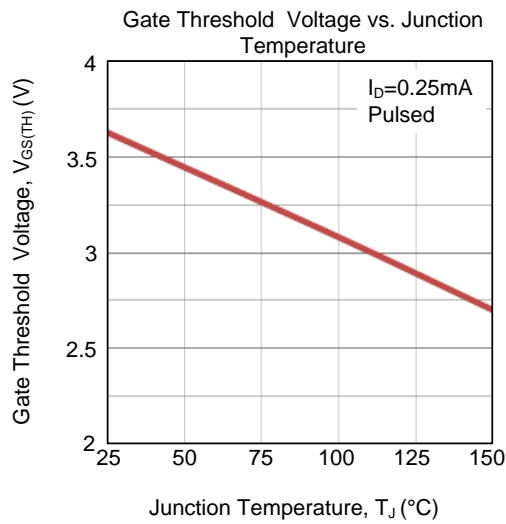

■ TYPICAL CHARACTERISTICS (Cont.)

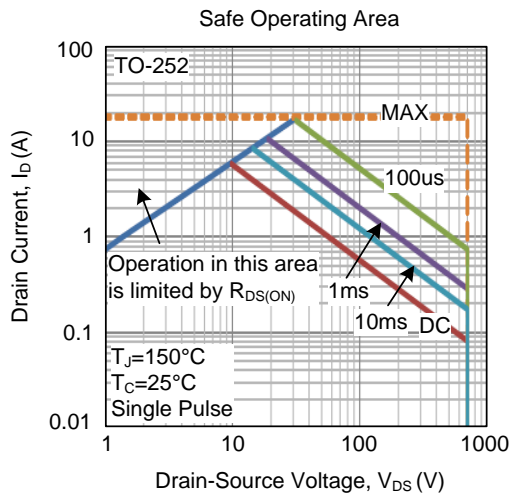

UTC assumes no responsibility for equipment failures that result from using products at values that exceed, even momentarily, rated values (such as maximum ratings, operating condition ranges, or other parameters) listed in products specifications of any and all UTC products described or contained herein. UTC products are not designed for use in life support appliances, devices or systems where malfunction of these products can be reasonably expected to result in personal injury. Reproduction in whole or in part is prohibited without the prior written consent of the copyright owner. UTC reserves the right to make changes to information published in this document, including without limitation specifications and product descriptions, at any time and without notice. This document supersedes and replaces all information supplied prior to the publication hereof.