



A2804

LINEAR INTEGRATED CIRCUIT

ZERO VOLTAGE SWITCH

DESCRIPTION

The UTC **A2804** is a TRIAC controller providing a complete solution for temperature controlled electric panel heaters, cookers, film processing baths etc.

Switching occurs at the zero voltage point in order to minimize radio frequency interference. The device is suitable for mains-on-line operation and requires minimal components.

FEATURES

- *Easy operation either through the AC line or a DC supply.
- *Supply voltage control.
- *Very few external components.
- *Symmetrical burst control-No DC current components in the load circuit
- *Negative output current pulse up to 250mA-short circuit protection.
- *Reference voltage output

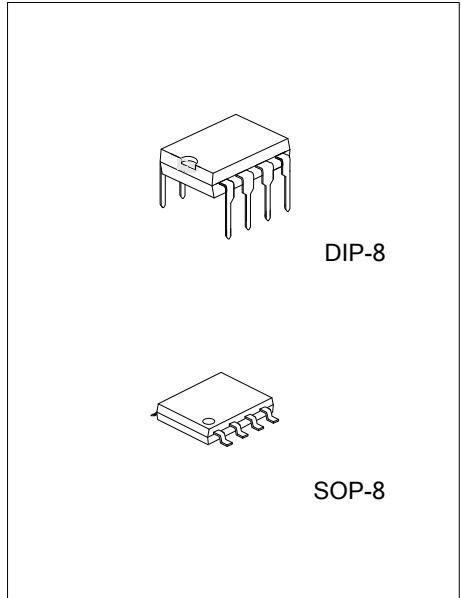

ORDERING INFORMATION

Ordering Number		Package	Packing
Lead Free	Halogen Free		
A2804L-D08-T	A2804G-D08-T	DIP-8	Tube
A2804L-S08-R	A2804G-S08-R	SOP-8	Tape Reel

<p>A2804G-D08-T</p> <p>(1)Packing Type</p> <p>(2)Package Type</p> <p>(3)Green Package</p>	<p>(1) T: Tube, R: Tape Reel</p> <p>(2) D08: DIP-8, S08: SOP-8</p> <p>(3) G: Halogen Free and Lead Free, L: Lead Free</p>
---	---

MARKING

DIP-8	SOP-8
<p>8 7 6 5 → Date Code</p> <p>UTC □ □ □ □</p> <p>A2804 □ □ □ □</p> <p>1 2 3 4 → Lot Code</p> <p>L: Lead Free</p> <p>G: Halogen Free</p>	<p>8 7 6 5 → Date Code</p> <p>UTC □ □ □ □</p> <p>A2804 □ □ □ □</p> <p>1 2 3 4 → Lot Code</p> <p>L: Lead Free</p> <p>G: Halogen Free</p>

PIN CONFIGURATION

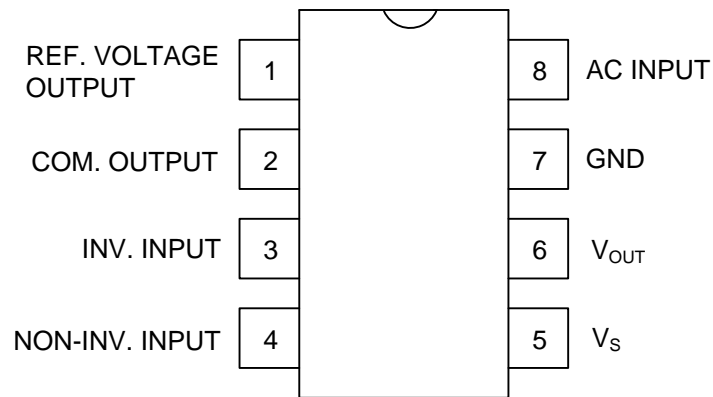

BLOCK DIAGRAM

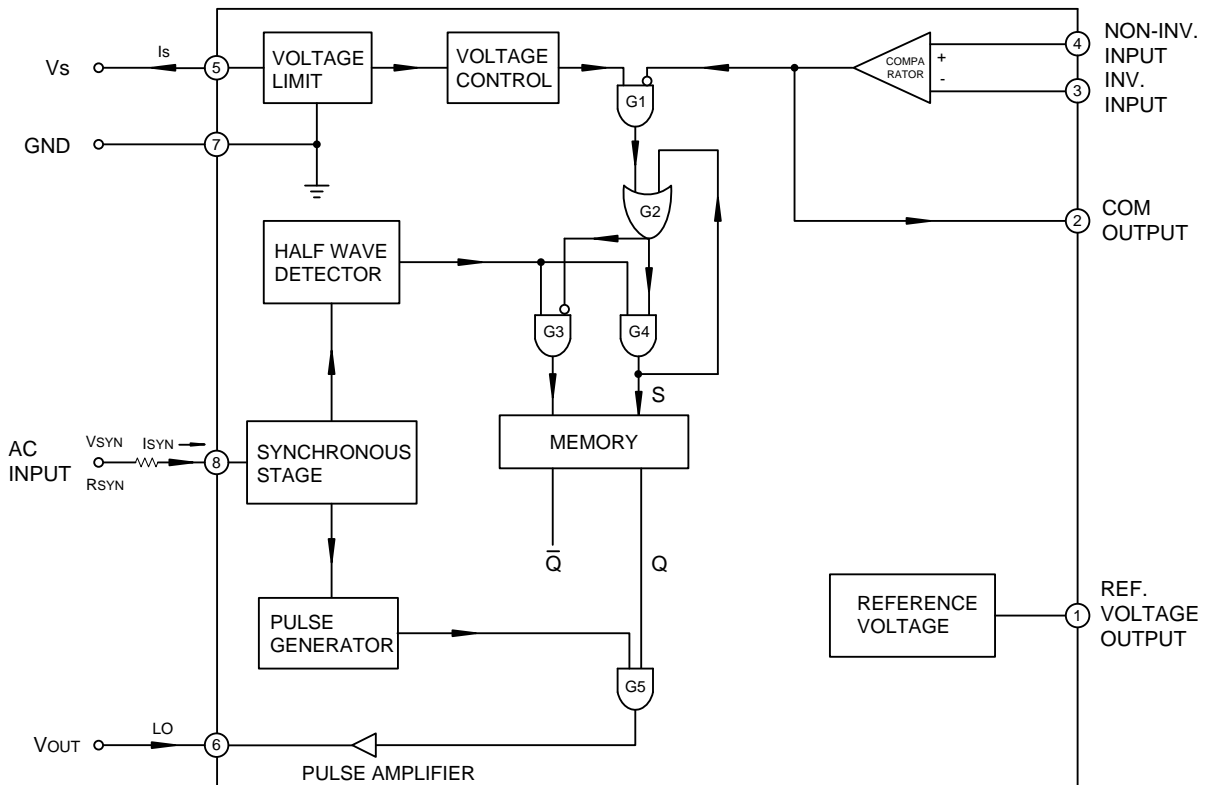

■ **ABSOLUTE MAXIMUM RATINGS** ($T_A=25^{\circ}\text{C}$, unless otherwise specified.)

PARAMETER	SYMBOL	RATINGS	UNIT
Supply Voltage	$-V_S$	8.2	V
Input Voltage	V_{IN}	$\leq IV_{SI}$	V
Supply Current	$-I_S$	40 _(AVERAGE)	mA
Synchronous Current	I_{SYN}	5.0 _(RMS)	mA
Power Dissipation	P_D	350	mW
Junction Temperature	T_J	+125	$^{\circ}\text{C}$
Operating Ambient Temperature	T_{OPR}	-20 ~ +70	$^{\circ}\text{C}$
Storage Temperature	T_{STG}	-65 ~ +150	$^{\circ}\text{C}$

Note: Absolute maximum ratings are those values beyond which the device could be permanently damaged. Absolute maximum ratings are stress ratings only and functional device operation is not implied.

■ **ELECTRICAL CHARACTERISTICS** ($V_S=8.0\text{V}$, $V_{SYN}=100 \sim 115\text{V}_{RMS}$, $T_A=25^{\circ}\text{C}$, $f=50/60\text{Hz}$)

PARAMETER	SYMBOL	PIN NO.	TEST CONDITIONS	MIN	TYP	MAX	UNIT
Output Voltage	V_{OUT}	6	$I_{OUT} \leq 150\text{mA}$	4.2	5.2	7.0	V
Input Offset Voltage	$V_{I(OFF)}$	3, 4			2.0	± 5.0	mV
Supply Voltage 1	$-V_{S1}$	5	$I_S=2.5\text{mA}$, $R_{SYN}=56\text{K}$	6.5		8.4	V
Supply Voltage 2	$-V_{S2}$	5	$I_S=20\text{mA}$, $R_{SYN}=56\text{K}$	8		8.9	V
Common Mode Input Voltage	$-V_{I(CM)}$	3, 4		0		5.7	V
Reference Voltage	$-V_R$	1	$I_R \leq 1\mu\text{A}$		3.6		V
Circuit Current	$-I_S$	5	$R_{SYN}=56\text{K}$	1.0	2.0	4.0	mA
Synchronous Current	I_{SYN}	8		0.3			mA
Output Current	I_{OUT}	6	$R_{OUT} \leq 25$	150	180		mA
Output Leakage Current	I_{LO}	6				± 2.0	μA
Input Bias Current	$I_{I(BIAS)}$	3, 4			0.5	± 1.0	μA
Output Leakage Current	I_{LC}	2				± 0.2	μA
Output Pulse Width	T_{PULSE}	6	$R_{SYN}=56\text{K}$	150	200	250	μs

■ TYPICAL APPLICATIONS

ON-OFF TEMPERATURE CONTROL

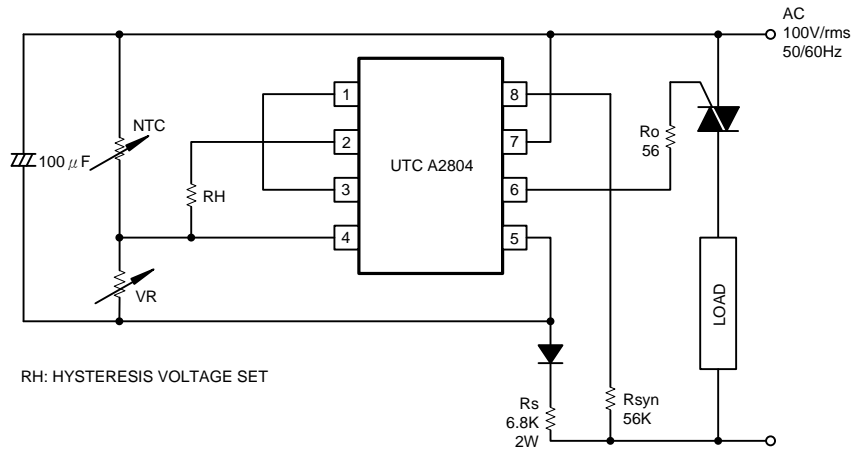

TIME PROPORTIONAL TEMPERATURE CONTROL

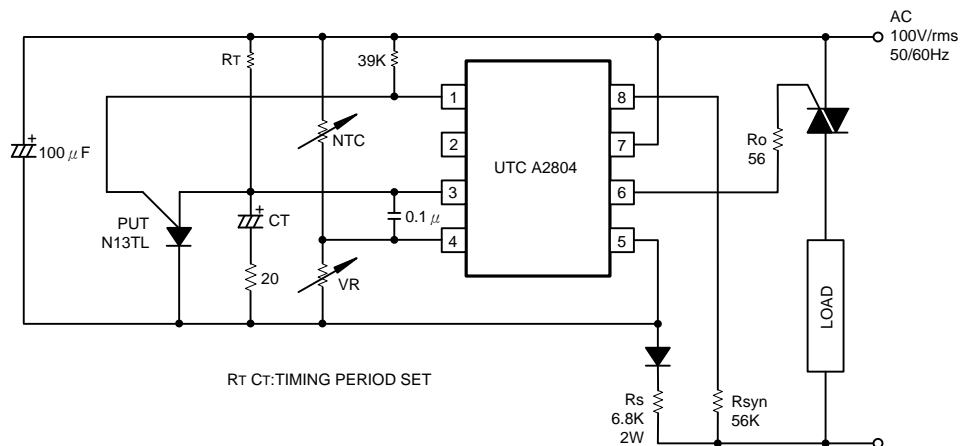

UTC assumes no responsibility for equipment failures that result from using products at values that exceed, even momentarily, rated values (such as maximum ratings, operating condition ranges, or other parameters) listed in products specifications of any and all UTC products described or contained herein. UTC products are not designed for use in life support appliances, devices or systems where malfunction of these products can be reasonably expected to result in personal injury. Reproduction in whole or in part is prohibited without the prior written consent of the copyright owner. UTC reserves the right to make changes to information published in this document, including without limitation specifications and product descriptions, at any time and without notice. This document supersedes and replaces all information supplied prior to the publication hereof.