



Specification for Approval

- DEVICE NUMBER: BWL-35C2R15-R1

SAMPLES
ATTACHED AREA

DATE \ PAGE	1	2	3	4	5	6	7				CONTENTS
2019/6/20	1.0	1.0	1.0	1.0	1.0	1.0	1.0	1.0			Initial Released

FOR CUSTOMER'S APPROVAL STAMP OR SIGNATURE

APPROVED	PURCHASE	MANUFACTURE	QUALITY	ENGINEERING

佰鴻工業股份有限公司
 BRIGHT LED ELECTRONICS CORP.
 新北市板橋區和平路 19 號 3 樓
 3F., No.19, He Ping Road,
 Ban Qiao Dist., New Taipei City,
 Taiwan
 Tel: +886-2-29591090
 Fax: +886-2-29547006/29558809
www.brtled.com

ISSUED	APPROVED	PREPARED
張孝嚴	謝皓翔	熊燦芬

● Features:

1. Input power: 1W.
2. Chip material: AlGaAs.
3. Emitted color: Red.
4. High lumen output.
5. High flux density.
6. Low power consumption.
7. Efficient heat transfer.
8. Exterior lens is silicone.
9. Add extra heat sink is necessary.

● Applications:

1. Torch.
2. Head Light.
3. Architectural Lighting.
4. LCD Backlight.

● Package dimensions :

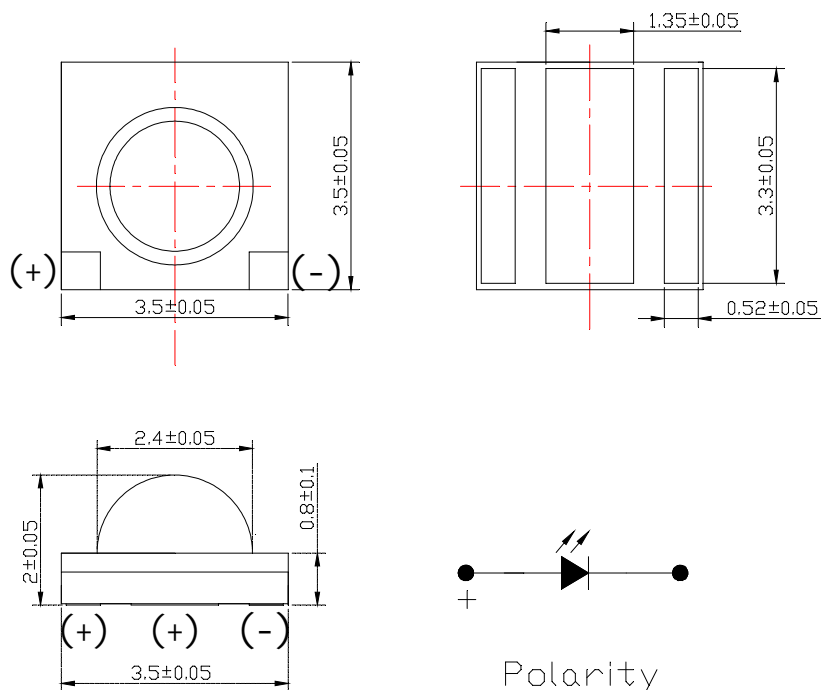

Notes:

1. All dimensions are in millimeters.
2. Tolerance is ± 0.25 mm unless otherwise specified.

● **Absolute maximum ratings (T_a=25°C)**

Parameter	Symbol	Rating	Unit
Power Dissipation	P _D	1.0	W
DC Forward Current	I _F	500	mA
Peak Pulsed Forward Current*	I _{FP}	0.7	A
LED Junction Temperature	T _J	115	°C
Operating Temperature	T _{opr}	-40~ +85	°C
Storage Temperature	T _{stg}	-40~ +100	°C
Reverse Voltage	V _R	5	V
Manual Soldering (T=5 sec)	T _{sol}	350 ± 5	°C

*Condition for I_{FP} is pulsed with 1/10 duty and 0.1msec width.

● **Electrical & Optical Characteristics (T_a=25°C)**

Parameter	Symbol	Condition	Min.	Typ.	Max.	Unit
Forward Voltage	V _F	I _F =500mA	2.0	-	3.2	V
Total Flux	Φ _v	I _F =500mA	20	28	-	lm
Peak Wavelength	λ _p	I _F =500mA	-	630	-	nm
Dominant Wavelength	λ _d	I _F =500mA	615	-	635	nm
Spectral Line Half-width	Δλ	I _F =500mA	-	25	-	nm
Reverse Current	I _R	V _R =5V	-	-	5	μA
Thermal Resistance, Junction To Case	Rθ _{J-C}	I _F =500mA	-	9	-	°C/W
Viewing Angle	2θ _{1/2}	I _F =500mA	-	120	-	degree

● Typical electro-optical characteristics curves

Fig.1 RELATIVE INTENSITY VS. WAVELENGTH

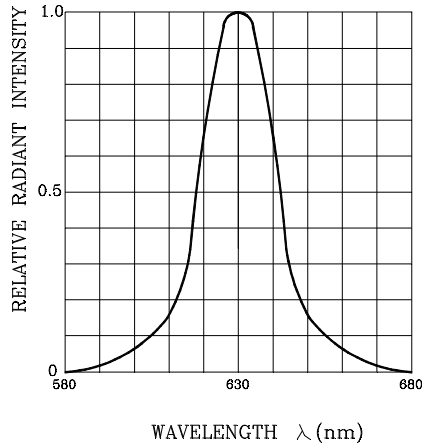

Fig.2 FORWARD CURRENT VS. AMBIENT TEMPERATURE

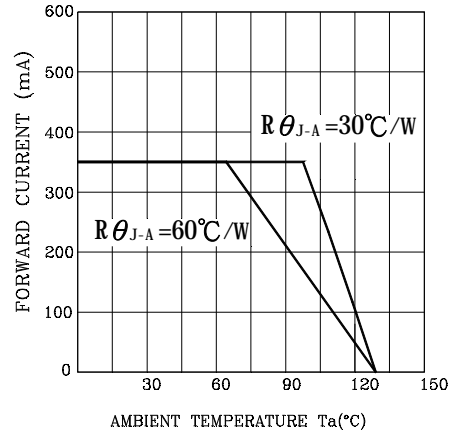

Fig.3 FORWARD CURRENT VS. FORWARD VOLTAGE

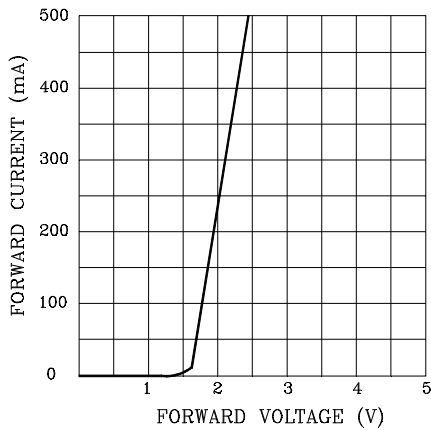

Fig.4 RELATIVE LUMINOUS INTENSITY VS. JUNCTION TEMPERATURE

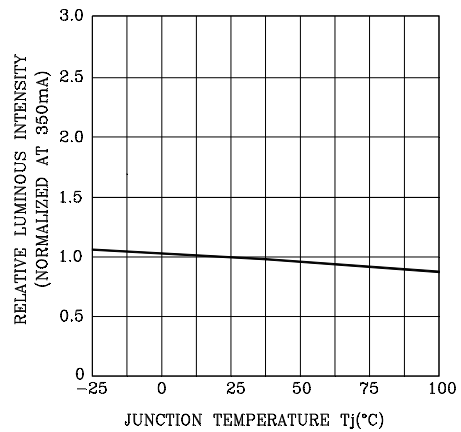

Fig.5 RELATIVE LUMINOUS INTENSITY VS. FORWARD CURRENT (at Ta=25°C)

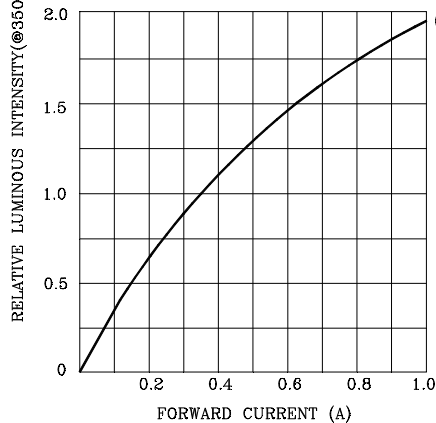
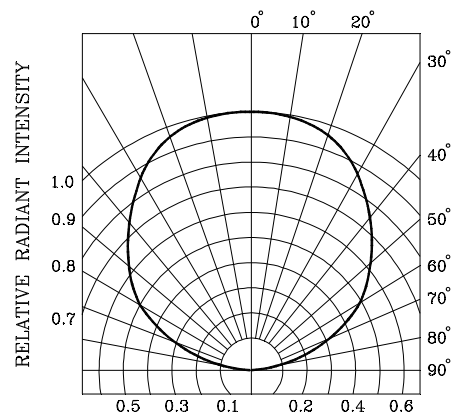

Fig.6 RADIATION DIAGRAM



● Total Flux Bin Limits (At 500mA)

BIN CODE	Min. (lm)	Max. (lm)
J	19	25
K	25	33
L	33	42

Tolerance for each Bin limit is $\pm 15\%$

● Color Bin Limits(At 500mA)

BIN CODE	Min. (nm)	Max. (nm)
3	615	625
4	625	635

● BIN : \underline{x} \underline{x}

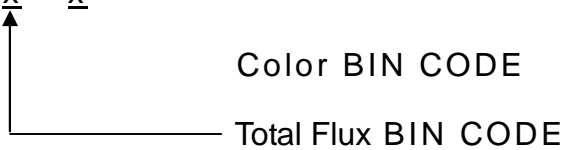

● Notes:

- Bin categories are established for classification of products. Products may not be available in all bin categories.

● Soldering :

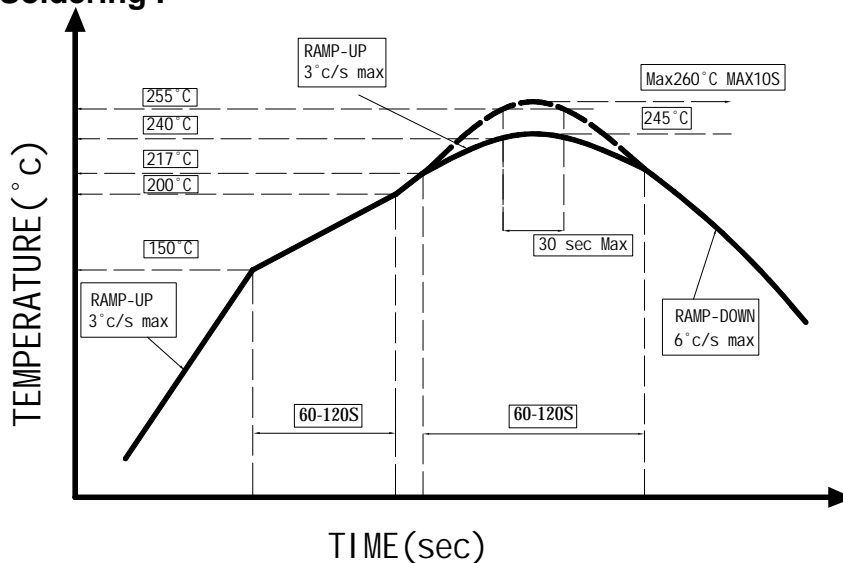

1. Avoid any external stress applied to the resin while the LEDs are at high temperature, especially during soldering .
2. Avoid rapid cooling or any excess vibration during temperature ramp-down process
3. Although the soldering condition is recommended above, soldering at the lowest possible temperature is feasible for the LEDs

● IRON Soldering

350°C Within 3 sec,one time only.

● Recommended Soldering Pattern (Unit:mm)

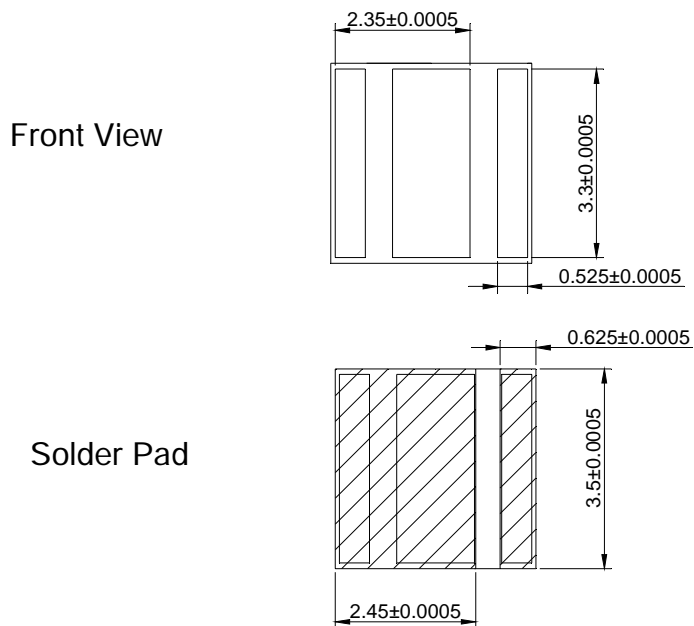

● Handling :

Care must be taken not to damage LED's silicone while exposing to high temperature or contact LED's silicone with hard or sharp objects, such as metal hook, tweezer or sand blasting.



BRIGHT LED ELECTRONICS CORP.

BWL-35C2R15-R1

● Notes for designing:

Current limiting resistor or a constant current power supply must be used in the circuit to drive BRIGHT LEDs within the rated figures and not to overload BRIGHT LEDs with instantaneous voltage at the turning ON and OFF cycles.

When using pulse driving, the average current must be within the rated figures. And the circuit should be designed to avoid reverse voltage when turning off the BRIGHT LEDs.

● Storage:

In order to avoid the absorption of moisture, it is recommended to solder BRIGHT LEDs as soon as possible after unpacking the sealed envelope.

If the envelope is still packed, to store it in the environment as following:

- (1) Temperature : 5°C-30°C (41°F) Humidity : RH 60% Max.
- (2) After this bag is opened, devices that will be applied to infrared reflow, vapor-phase reflow, or equivalent soldering process must be:
 - a. Completed within 24 hours.
 - b. Stored at less than 20% RH.
- (3) Devices require baking before mounting, if:
 - (2) a or (2) b is not met.
- (4) If baking is required, devices must be baked under below conditions:
 - 48 hours at 60°C±5°C.

● Package and Label of Products:

- (1) Package: Products are packed in one bag of 800 pcs (one taping reel) and a label is attached to each bag.
- (2) Label:

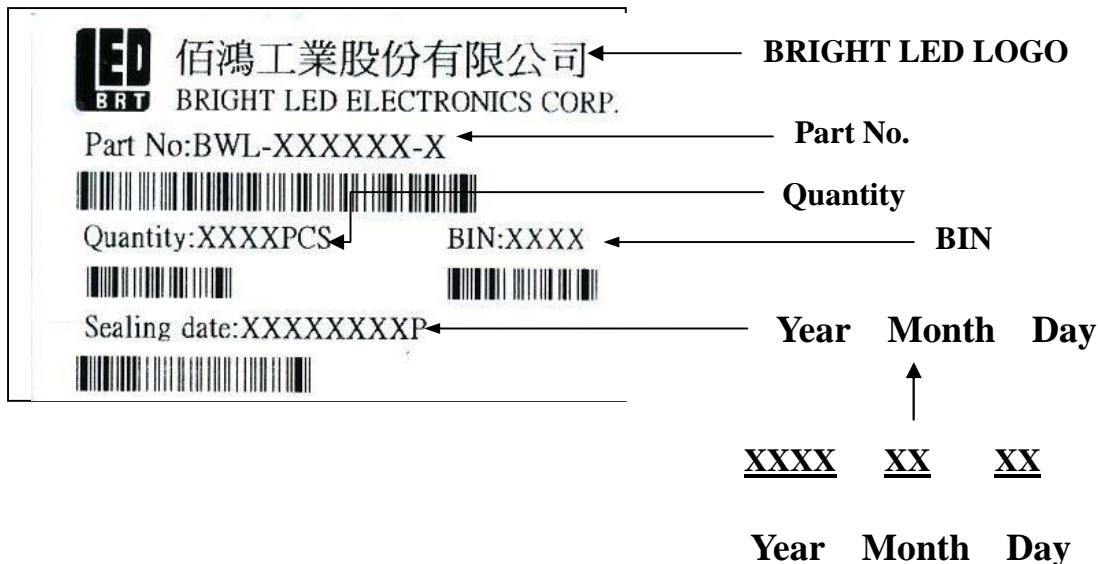

● Tapping and packaging specifications (Units: mm)

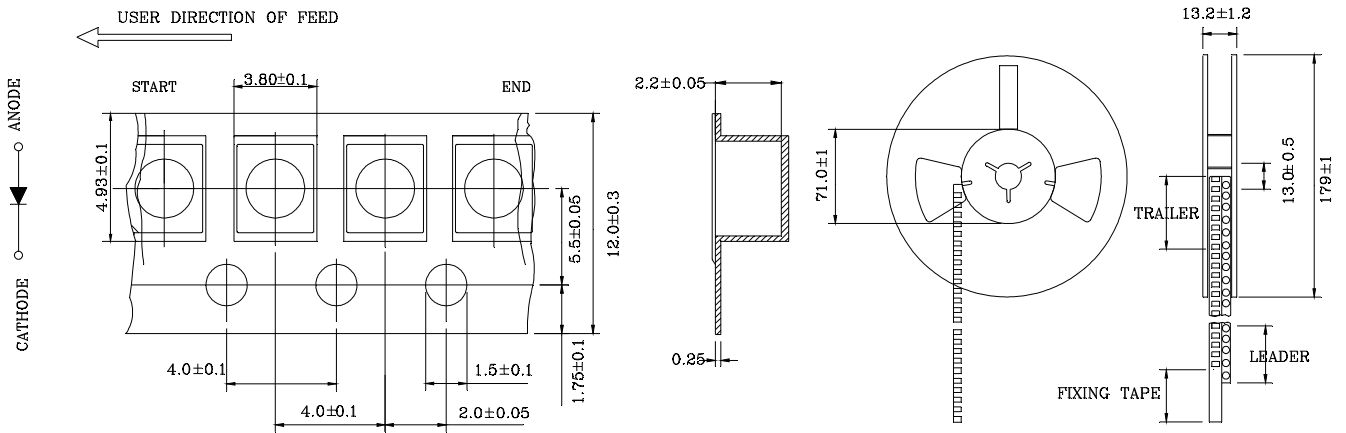

NOTE: 800 PCS PER REEL

Package Method (unit:mm)

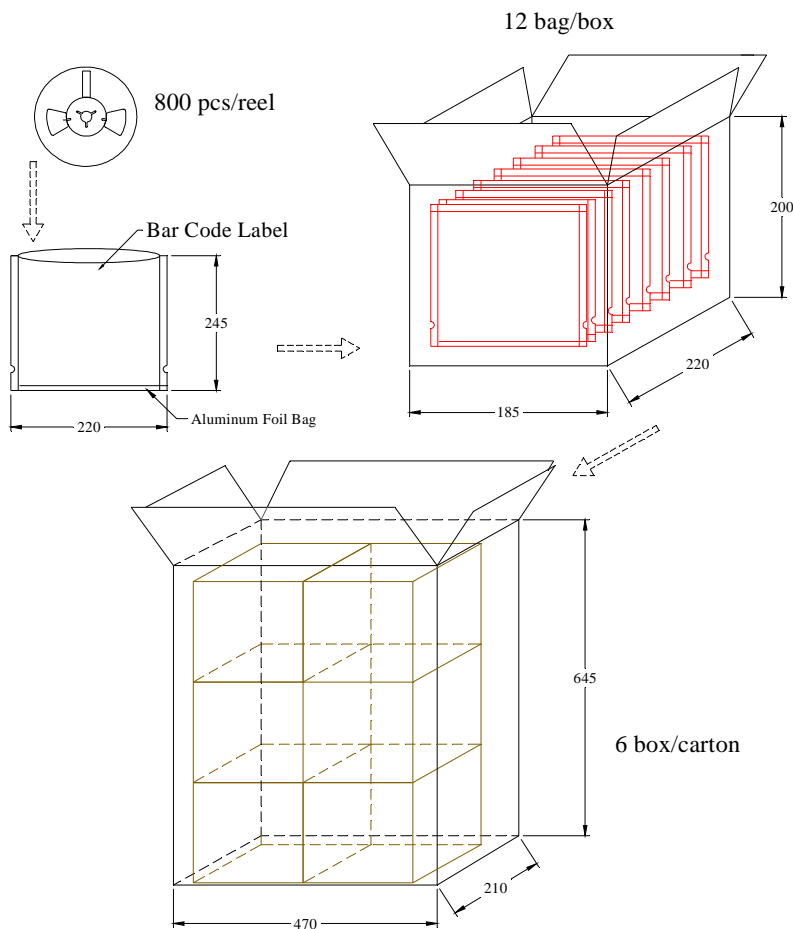

NOTES : Bag : Tolerance is ± 5 mm unless otherwise noted.

Carton : Tolerance is ± 10 mm unless otherwise noted.