



F2867

LINEAR INTEGRATED CIRCUIT

VARIABLE SPEED SINGLE-PHASE FULL-WAVE PRE-DRIVER

DESCRIPTION

The UTC **F2867** is a single-phase bipolar variable speed driving motor pre-driver that works with external PWM signal. A highly efficient, highly silent and low power consumption motor driver circuit can be achieved with a few external parts. This product is optimal for driving large scale fan motors requiring large air flow and large current such as servers and consumer appliances.

FEATURES

- * Pre-driver for single-phase full-wave drive
Low-saturation drive using external PMOS-NMOS enables high-efficiency low power-consumption drive.
- * External PWM input enabling variable speed control
Separately-excited upper direct PWM (f=30kHz) control method enabling highly silent speed control.
- * Current limiting circuit incorporated
Chopper type current limit at start.
- * Reactive current cut circuit incorporated
Reactive current before phase change is cut to enable silent and low power-consumption drive.
- * Minimum speed setting pin
Minimum speed can be set by set with external resistor.
- * Soft start setting pin
- * Lock protection and automatic reset functions incorporated
- * FG (rotation speed detection) output
- * Thermal shutdown circuit incorporated

ORDERING INFORMATION

Ordering Number		Package	Packing
Lead Free	Halogen Free		
F2867L-R16-R	F2867G-R16-R	SSOP-16	Tape Reel
F2867L-P16-R	F2867G-P16-R	TSSOP-16	Tape Reel

<p>F2867G-R16-R</p> <p>(1)Packing Type (2)Package Type (3)Green Package</p>	<p>(1) R: Tape Reel (2) R16: SSOP-16, P16: TSSOP-16 (3) G: Halogen Free and Lead Free, L: Lead Free</p>
---	---

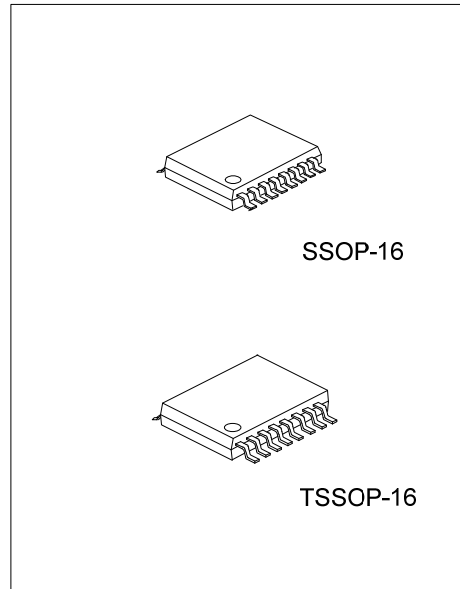

MARKING

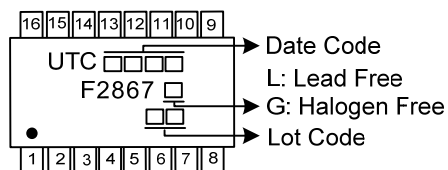

PIN CONFIGURATION

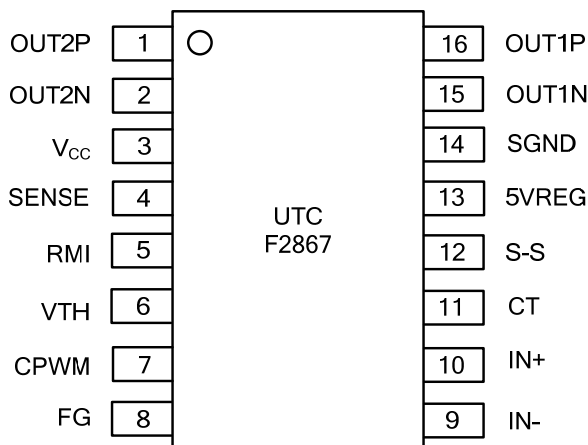

PIN DESCRIPTION

PIN NO.	PIN NAME	DESCRIPTION
1	OUT2P	Output2 PMOS drive
2	OUT2N	Output2 NMOS drive
3	V _{CC}	Power supply
4	SENSE	Current limiting detection pin
5	RMI	Minimum speed setting pin
6	V _{TH}	Speed control pin
7	CPWM	Pin to connect the capacitor for generation of the PWM basic frequency
8	FG	Rotation speed detection pin
9	IN ⁻	Hall signal input
10	IN ⁺	Hall signal input
11	CT	Pin to connect the lock detection capacitor
12	S-S	Pin to connect the soft-start setting capacitor
13	5VREG	5V reference voltage
14	SGND	Power-GND
15	OUT1N	Output1 NMOS drive
16	OUT1P	Output1 PMOS drive

■ BLOCK DIAGRAM

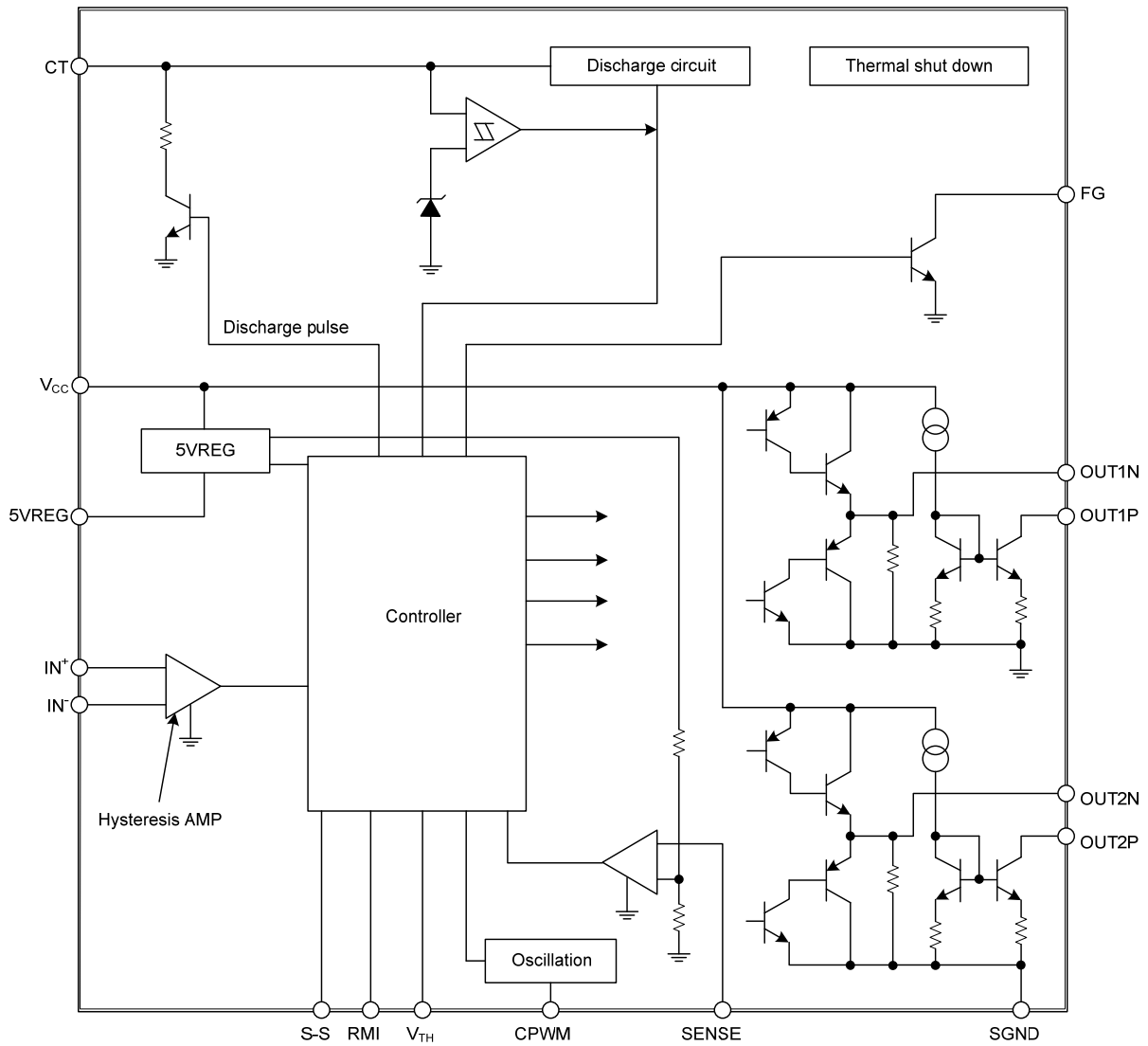

FLYING 汎翔國際有限公司
www.flying1688.com

■ ABSOLUTE MAXIMUM RATING (T_A=25°C unless otherwise specified)

PARAMETER	SYMBOL	RATINGS	UNIT
V _{CC} Pin Maximum Supply Voltage	V _{CC}	18	V
OUTN Pin Maximum Output Current	I _{OUTN}	20	mA
OUTP Pin Maximum Sink Current	I _{OUTP}	20	mA
OUT Pin Output Withstand Voltage	V _{OUT}	18	V
V _{TH} , RMI Pins Withstand Voltage	V _{VTH} , V _{RMI}	7	V
S-S Pin Withstand Voltage	V _{S-S}	7	V
FG Output Pin Withstand Voltage	V _{FG}	19	V
FG Pin Maximum Output Current	I _{FG}	10	mA
5VREG Pin Maximum Output Current	I _{5VREG}	20	mA
Allowable Power Dissipation (with specified substrate (Note 2))	P _D	800	mW
Operating Temperature (Note 3)	T _{OPR}	-30 ~ +95	°C
Storage Temperature	T _{STG}	-55 ~ +150	°C

Notes: 1. Absolute maximum ratings are those values beyond which the device could be permanently damaged.

Absolute maximum ratings are stress ratings only and functional device operation is not implied.

2. Specified substrate: 114.3mm×76.1mm×1.6mm, glass epoxy board.

3. T_J max=125°C must not be exceeded.

■ RECOMMENDED OPERATING CONDITIONS (T_A=25°C unless otherwise specified)

PARAMETER	SYMBOL	RATINGS	UNIT
V _{CC} Supply Voltage	V _{CC}	5.5 ~ 16	V
V _{TH} , RMI Input Voltage Range	V _{TH} , R _{MII}	0 ~ 5	V
Hall Input Common-Phase Input Voltage Range	V _{ICM}	0.2 ~ 3	V

■ ELECTRICAL CHARACTERISTICS (V_{CC}=12V, T_A=25°C unless otherwise specified)

PARAMETER	SYMBOL	TEST CONDITIONS	MIN	TYP	MAX	UNIT
Circuit Current	I _{CC1}	During drive	5.5	7.5	9.5	mA
	I _{CC2}	During lock protection	5.5	7.5	9.5	mA
5VREG Voltage	5V _{REG}	I _{5VREG} = 5mA	4.80	4.95	5.10	V
Current Limiting Voltage	V _{LIM}		185	200	215	mV
CPWM Pin "h" Level Voltage	V _{CPWM H}		2.8	3.0	3.2	V
CPWM Pin "L" Level Voltage	V _{CPWM L}		0.9	1.1	1.3	V
CPWM Pin Charge Current	I _{CPWM1}	V _{CPWM} =0.5V	24	30	36	μA
CPWM Pin Discharge Current	I _{CPWM2}	V _{CPWM} =3.5V	21	27	33	μA
CPWM Oscillation Frequency	F _{PWM}	C=220PF		30		kHz
CT Pin "H" Level Voltage	V _{CTH}		2.8	3.0	3.2	V
CT Pin "L" Level Voltage	V _{CTL}		0.9	1.1	1.3	V
CT Pin Charge Current	I _{CT1}	V _{CT} =0.5V	1.6	2.0	2.5	μA
CT Pin Discharge Current	I _{CT2}	V _{CT} =3.5V	0.16	0.20	0.25	μA
CT Pin Charge/Discharge Ratio	R _{CT}	I _{CT1} /I _{CT2}	8	10	12	times
S-S Pin Discharge Current	I _{S-S}	V _{S-S} =1V	0.4	0.5	0.6	μA
OUTN Output H-level Voltage	V _{ONH}	I _O =10mA		V _{CC} -0.85	V _{CC} -1.00	V
OUTN Output L-level Voltage	V _{ONL}	I _O =10mA		0.9	1.1	V
OUTP Output L-level Voltage	V _{OPL}	I _O =10mA		0.5	0.65	V
Hall Input Sensitivity	V _{HN}	IN ⁺ , IN ⁻ differential voltage (including offset and hysteresis)		±10	±20	mV
FG Output L-level Voltage	V _{FGL}	I _{FG} =5mA		0.15	0.30	V
FG Pin Leakage Current	I _{FGL}	V _{FG} =19V			20	μA
V _{TH} /RMI Pin Bias Current	I _{VTH} /I _{RMI}	CPWM=V _{TH} /RMI=2V			0.2	μA

■ TYPICAL APPLICATION CIRCUIT

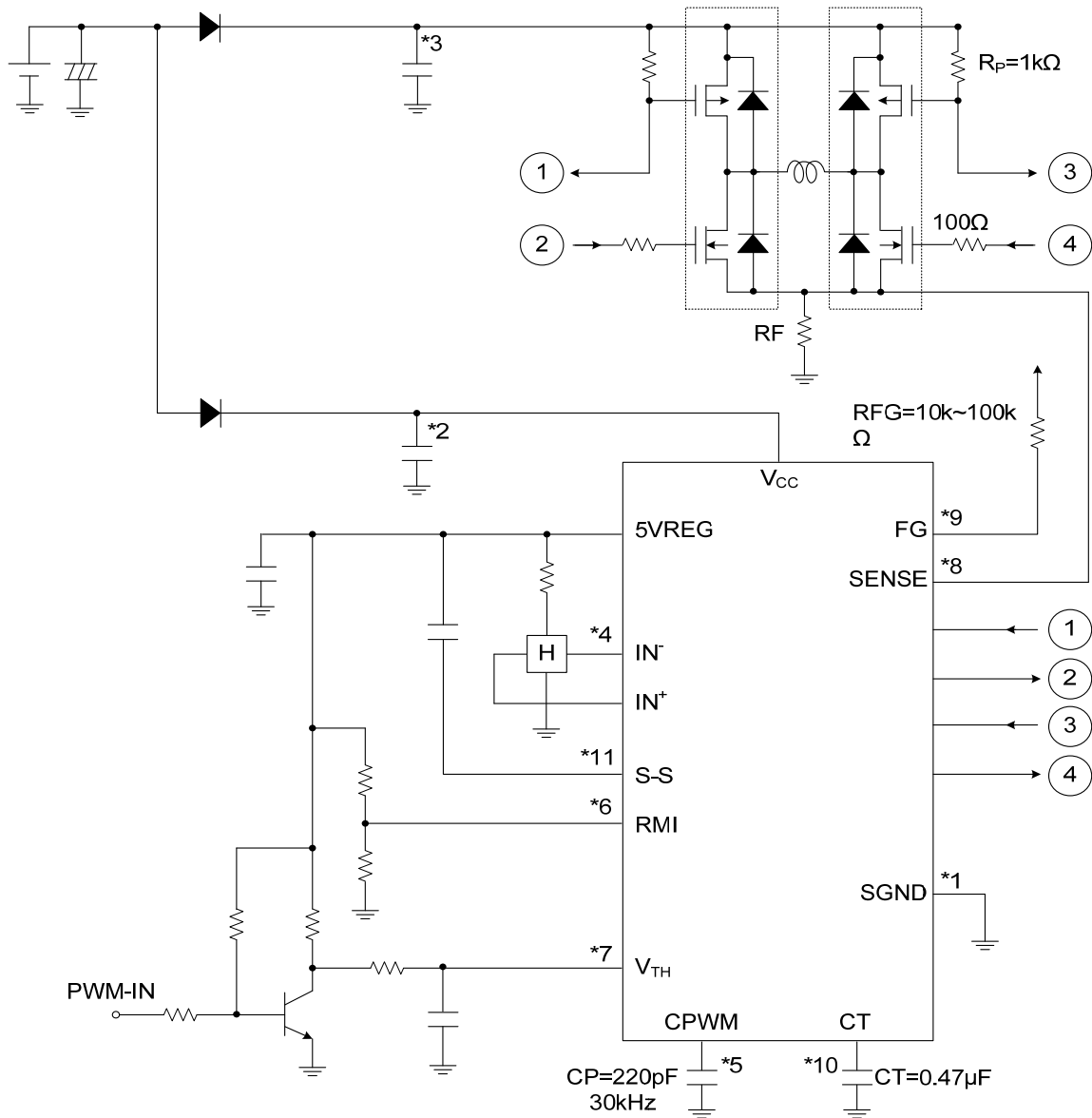

Notes: *1. Power-GND wiring

SGND is connected to the control circuit power supply system.

*2. Power stabilization capacitor

For the power stabilization capacitor on the signal side, use the capacitance of 1µF or more. Connect V_{CC} and GND with a thick and shortest pattern.

*3. Power stabilization capacitor on the power side

For the power stabilization capacitor on the power side, use the capacitance of 1µF or more. Connect the power supply on the power side and GND with a thick and shortest pattern.

*4. IN⁺, IN⁻ pins

Hall signal input pin.

Wiring should be short to prevent carrying of noise.

If noise is carried, insert the capacitor between IN⁺ and IN⁻ pins.

The Hall input circuit functions as a comparator with hysteresis (15mV).

This also has a soft switch section with ±30mV (input signal differential voltage).

It is also recommended that the Hall input level is minimum 100mV (p-p).

■ TYPICAL APPLICATION CIRCUIT (Cont.)

Notes: *5. CPWM pin

Pin to connect the capacitor for generation of the PWM basic frequency

The use of $CP=220\text{pF}$ causes oscillation at $f=30\text{kHz}$, which is the basic frequency of PWM.

As this is used also for the current limiting canceling signal, be sure to connect the capacitor even when the speed control is not made.

*6. RMI pin

Minimum speed setting pin.

Perform pull-up with 5VREG when this pin is not to be used.

If the IC power supply is likely to be turned OFF first when the pin is used with external power supply, be sure to insert the current limiting resistor to prevent inflow of large current. (The same applies to the V_{TH} pin.)

*7. V_{TH} pin

Speed control pin.

Connect this pin to GND when it is not used (at full speed).

For the control method, refer to the timing chart.

For control with pulse input, insert the current limiting resistor and use the pin with the frequency of 20k~100kHz (20kHz~50kHz recommended).

*8. SENSE pin

Current limiting detection pin.

When the pin voltage exceeds 0.2V, the current is limited and the operation enters the lower regeneration mode.

Connect this pin to GND when it is not to be used.

*9. FG pin

Rotation speed detection pin.

This is an open collector output, which can detect the rotation speed from the FG output according to the phase changeover.

Keep this pin open when it is not to be used.

*10. CT pin

Pin to connect the lock detection capacitor.

The constant-current charge and discharge circuits incorporated cause locking when the pin voltage becomes 3.0V and unlocking when it is 1.1V. Connect the pin to GND when it is not to be used (locking not necessary).

*11. S-S pin

Pin to connect the soft-start setting capacitor.

Connect the capacitor between 5VREG and S-S pin.

This pin enables setting of the soft start time according to the capacity of the capacitor.

See the timing char.

Connect the pin to GND when it is not to be used.

UTC assumes no responsibility for equipment failures that result from using products at values that exceed, even momentarily, rated values (such as maximum ratings, operating condition ranges, or other parameters) listed in products specifications of any and all UTC products described or contained herein. UTC products are not designed for use in life support appliances, devices or systems where malfunction of these products can be reasonably expected to result in personal injury. Reproduction in whole or in part is prohibited without the prior written consent of the copyright owner. UTC reserves the right to make changes to information published in this document, including without limitation specifications and product descriptions, at any time and without notice. This document supersedes and replaces all information supplied prior to the publication hereof.