



FMMT619

NPN SILICON TRANSISTOR

BIPOLAR POWER GENERAL PURPOSE TRANSISTOR

■ APPLICATIONS

- * DC-DC / DC-AC Modules
- * Regulator
- * LED driver
- * CCFL Backlighting Inverters

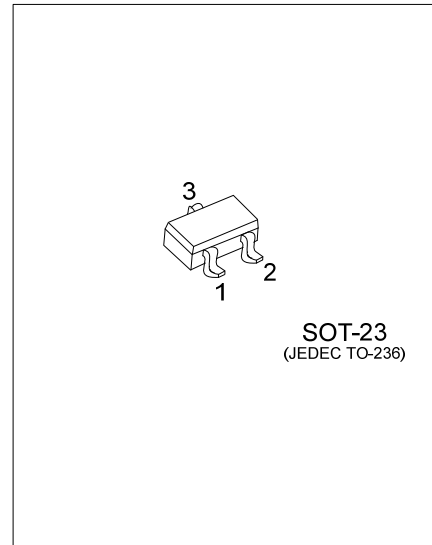

■ ORDERING INFORMATION

Ordering Number		Package	Pin Assignment			Packing
Lead Free	Halogen Free		1	2	3	
FMMT619G-AE3-6-R	FMMT619G-AE3-6-R	SOT-23	B	E	C	Tape Reel

Note: Pin Assignment: B: Base E: Emitter C: Collector

<p>FMMT619G-AE3-6-R</p> <p>(1) Packing Type (2) Pin Assignment (3) Package Type (4) Green Package</p>	<p>(1) R: Tape Reel (2) refer to Pin Assignment (3) AE3: SOT-23 (4) G: Halogen Free and Lead Free, L: Lead Free</p>
---	---

■ MARKING

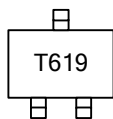

FLYING 汎翔國際有限公司
 www.flying1688.com

■ ABSOLUTE MAXIMUM RATING ($T_A=25^{\circ}\text{C}$ unless otherwise specified)

PARAMETER	SYMBOL	RATINGS	UNIT
Collector-Base Voltage	V_{CBO}	125	V
Collector-Emitter Voltage	V_{CEO}	125	V
Emitter-Base Voltage	V_{EBO}	5	V
Collector Current	I_C	1	A
Collector Peak Current	$I_{C(PEAK)}$	3	A
Base Current	I_B	0.5	A
Power Dissipation	P_D	0.35	W
Junction Temperature	T_J	+150	$^{\circ}\text{C}$
Storage Temperature	T_{STG}	-40 ~ +150	$^{\circ}\text{C}$

Note: Absolute maximum ratings are those values beyond which the device could be permanently damaged. Absolute maximum ratings are stress ratings only and functional device operation is not implied.

■ THERMAL CHARACTERISTICS

PARAMETER	SYMBOL	RATINGS	UNIT
Junction to Case	θ_{JC}	110	$^{\circ}\text{C/W}$

■ ELECTRICAL CHARACTERISTICS ($T_A=25^{\circ}\text{C}$, unless otherwise specified)

PARAMETER	SYMBOL	TEST CONDITIONS	MIN	TYP	MAX	UNIT
OFF CHARACTERISTICS						
Collector to Base Breakdown Voltage	BV_{CBO}	$I_C=1\text{mA}, I_E=0$	125			V
Collector to Emitter Breakdown Voltage	BV_{CEO}	$I_C=10\text{mA}, R_{BE}=\infty$	125			V
Emitter to Base Breakdown Voltage	BV_{EBO}	$I_E=1\text{mA}, I_C=0$	5			V
Collector Cut-off Current	I_{CBO}	$V_{CB}=120\text{V}, I_E=0$			0.5	μA
Emitter Cutoff Current	I_{EBO}	$V_{EB}=5\text{V}, I_C=0$			0.1	μA
ON CHARACTERISTICS						
DC Current Gain	h_{FE1}	$V_{CE}=5\text{V}, I_C=150\text{mA}$ (Note)	160		320	
	h_{FE2}	$V_{CE}=5\text{V}, I_C=500\text{mA}$ (Note)	30			
Collector-Emitter Saturation Voltage	$V_{CE(SAT)}$	$I_C=500\text{mA}, I_B=50\text{mA}$ (Note)			0.5	V
Base-Emitter Saturation Voltage	$V_{BE(SAT)}$	$I_C=600\text{mA}, I_B=50\text{mA}$ (Note)			1.0	V
Base-Emitter Voltage	V_{BE}	$V_{CE}=5\text{V}, I_C=150\text{mA}$ (Note)			1.5	V
DYNAMIC CHARACTERISTICS						
Current Gain Bandwidth Product	f_T	$V_{CE}=5\text{V}, I_C=150\text{mA}$ (Note)		140		MHz
Output Capacitance	C_{ob}	$V_{CB}=10\text{V}, I_E=0, f=1\text{MHz}$		14		pF
SWITCHING CHARACTERISTICS						
Rise Time	t_r	$V_{CC}=50\text{V}, I_C=0.5\text{A}, I_{B1}=I_{B2}=10\text{mA}, t_p=25\mu\text{s}, \text{Duty Cycle}\leq 1\%$		0.5		μs
Storage Time	t_s			1.5		
Fall Time	t_f			0.7		

Note: Pulse test.

TYPICAL CHARACTERISTICS

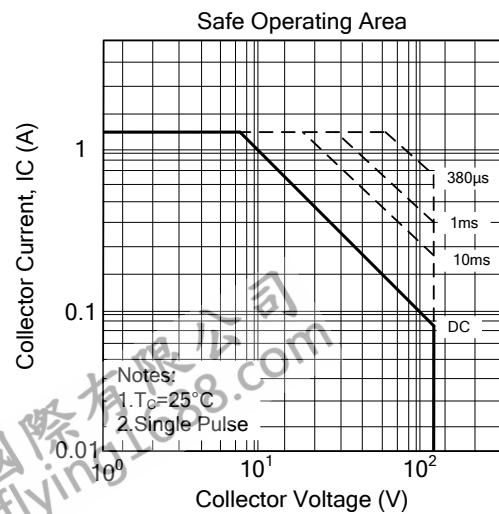
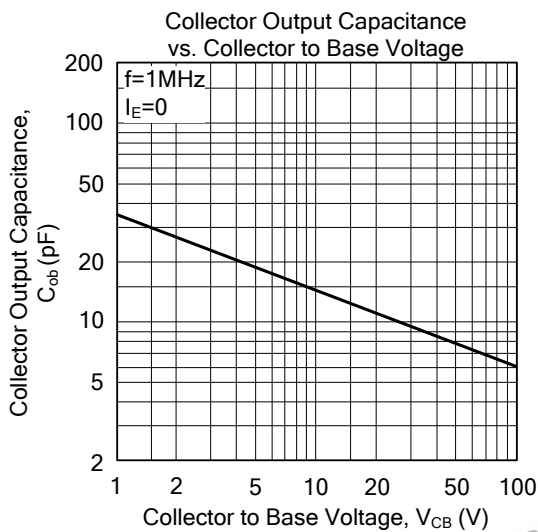
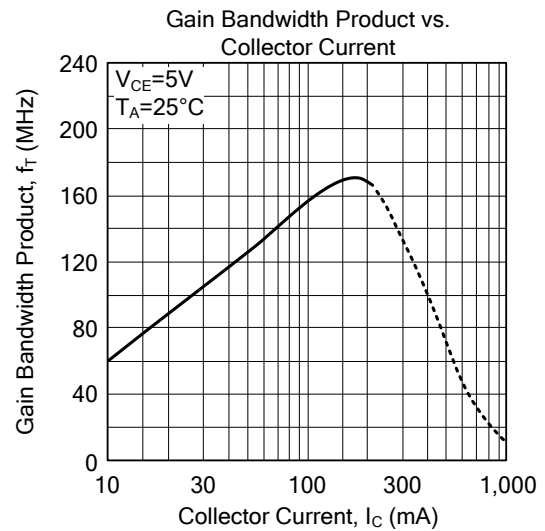
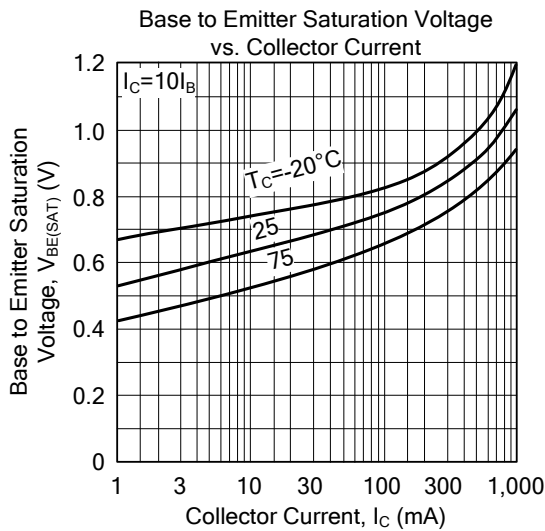
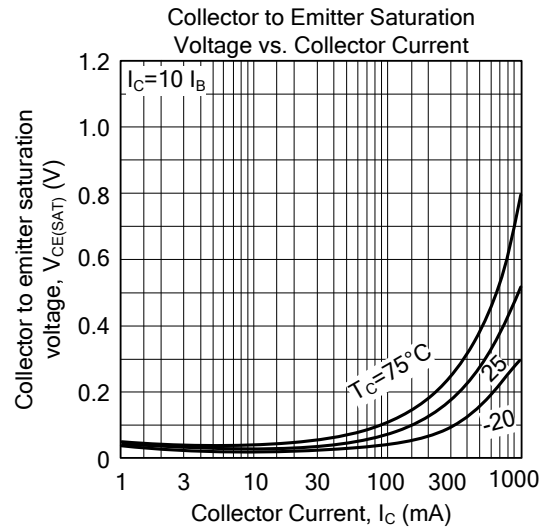
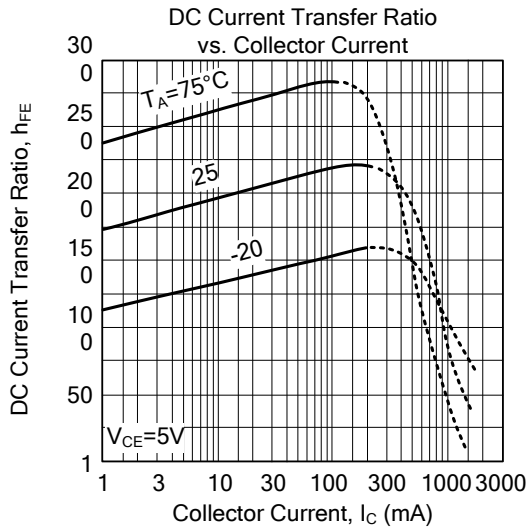

■ TYPICAL CHARACTERISTICS(Cont.)

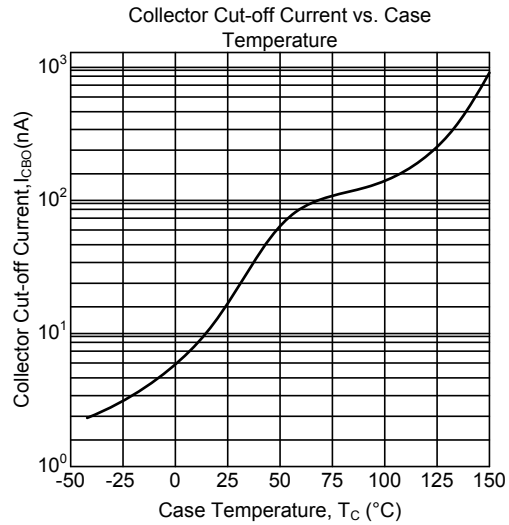
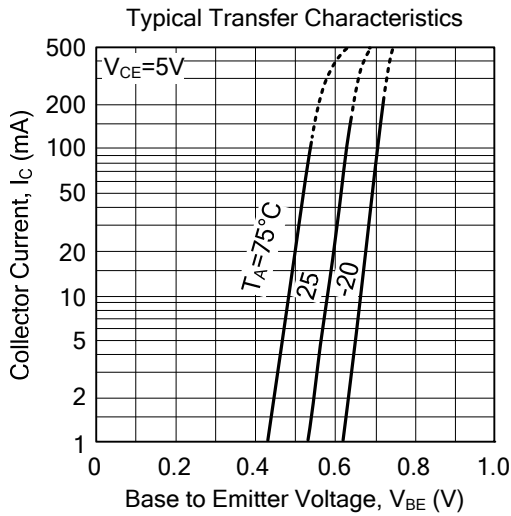

UTC assumes no responsibility for equipment failures that result from using products at values that exceed, even momentarily, rated values (such as maximum ratings, operating condition ranges, or other parameters) listed in products specifications of any and all UTC products described or contained herein. UTC products are not designed for use in life support appliances, devices or systems where malfunction of these products can be reasonably expected to result in personal injury. Reproduction in whole or in part is prohibited without the prior written consent of the copyright owner. UTC reserves the right to make changes to information published in this document, including without limitation specifications and product descriptions, at any time and without notice. This document supersedes and replaces all information supplied prior to the publication hereof.