



L16B40

Preliminary

CMOS IC

16-BIT CONSTANT CURRENT LED DRIVER WITH BUILT-IN TO ELIMINATE THE GHOSTING

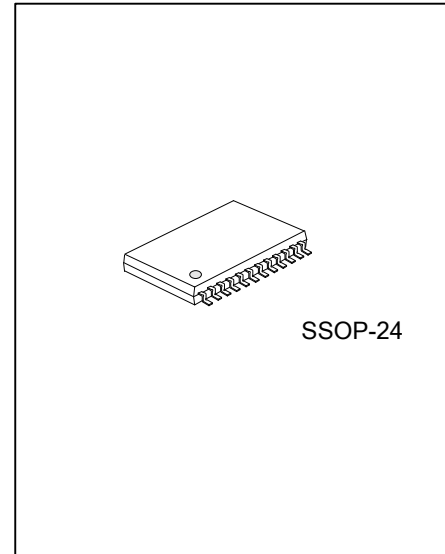

DESCRIPTION

UTC **L16B40** is a new 16-bit constant current LED driver IC with 20V output rating. Output currents with high accuracy and consistency can be preset through an external resistor. The output current ranges from 2mA to 40mA.

Moreover, the fast current response time and built-in to eliminate the ghosting make UTC **L16B40** performing better in output current and display image.

FEATURES

- * Built-in to eliminate the ghosting
- * Supply voltage range: 3.3V ~ 5.5V
- * Constant output current range: 2 ~ 40mA
- * Output voltage: 20V (Max.)
- * Operating temperature range: -40°C ~ 85°C
- * Output current accuracy:
ICs: ±3.0% (Typ.)

ORDERING INFORMATION

| Ordering Number | Package | Packing |
|-----------------|---------|-----------|
| L16B40G-R24-R | SSOP-24 | Tape Reel |

| | |
|----------------------------------------------------------------------------------------------------------------------------------------------|-----------------------------------------------------------------------------------------------------------------------------------------|
| <p>L16B40G-R24-R</p> <ul style="list-style-type: none"> (1) Packing Type (2) Package Type (3) Green Package | <ul style="list-style-type: none"> (1) R: Tape Reel (2) R24: SSOP-24 (3) G: Halogen Free and Lead Free |
|----------------------------------------------------------------------------------------------------------------------------------------------|-----------------------------------------------------------------------------------------------------------------------------------------|

MARKING

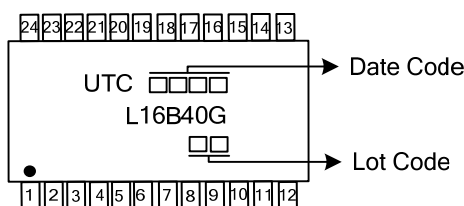

PIN CONFIGURATION

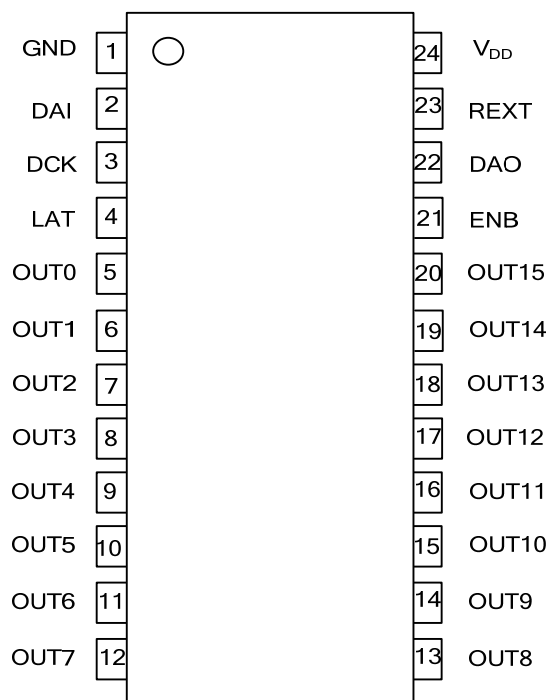

■ PIN DESCRIPTION

| PIN NO. | PIN NAME | DESCRIPTION |
|---------|-----------------|-----------------------------------------------------------------------------------|
| 1 | GND | Ground |
| 2 | DAI | Serial-data input |
| 3 | DCK | Clock input |
| 4 | LAT | Data strobe signal input |
| 5~20 | OUT0 ~15 | Constant current outputs |
| 21 | ENB | Enable signal input |
| 22 | DAO | Serial-data output |
| 23 | REXT | Input terminal used to connect an external resistor for setting up output current |
| 24 | V _{DD} | Supply voltage |

■ BLOCK DIAGRAM

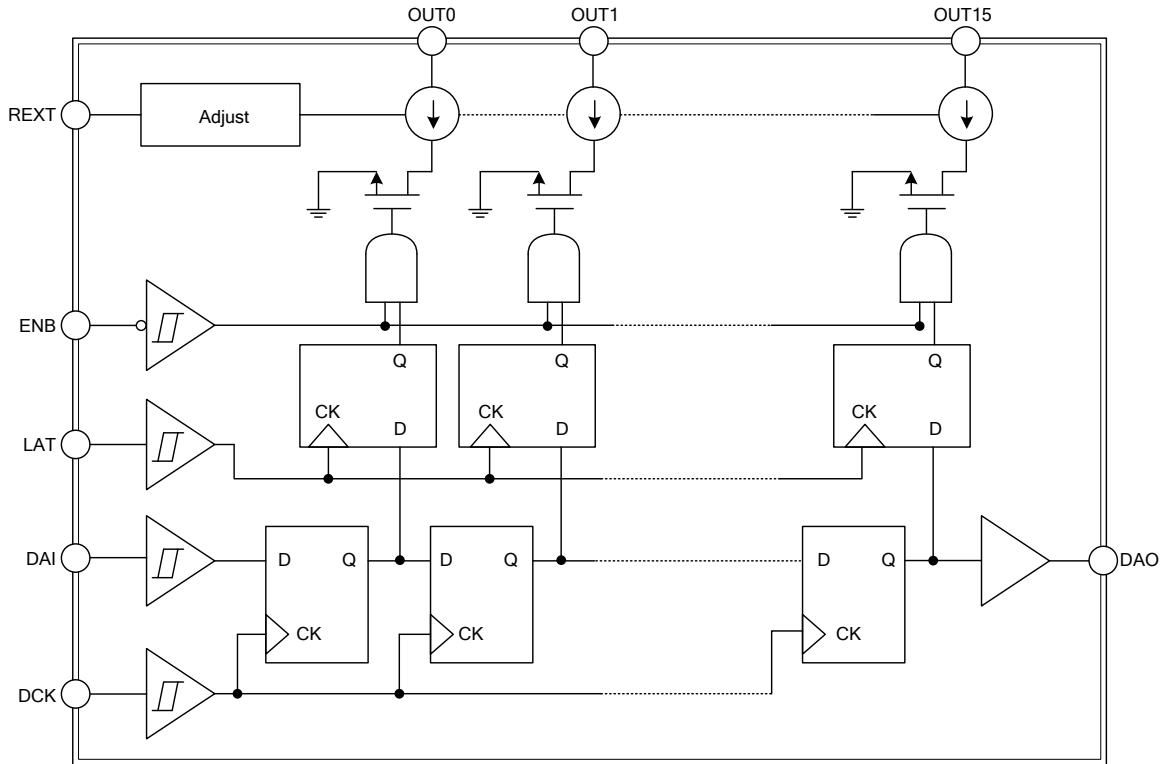

■ EQUIVALENT CIRCUITS OF INPUTS AND OUTPUTS

DAI/DCK

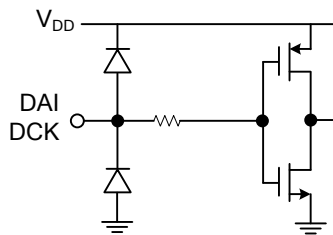

LAT

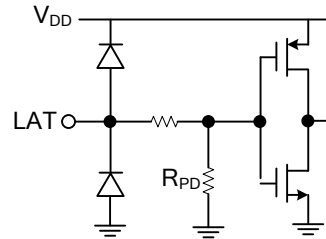

DAO

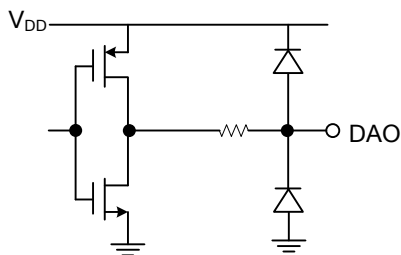

ENB

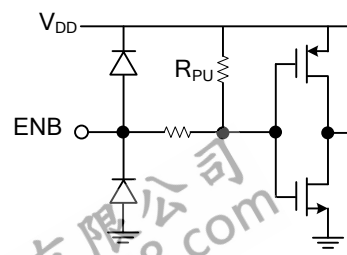

■ ABSOLUTE MAXIMUM RATING ($T_A=25^{\circ}\text{C}$, unless otherwise specified)

| PARAMETER | SYMBOL | RATINGS | UNIT |
|-----------------------------|---------------|---------------------|-----------------------------|
| Supply Voltage Range | V_{DD} | 0 ~ 7.0 | V |
| Input Voltage Range | V_{IN} | -0.4 ~ $V_{DD}+0.4$ | V |
| Output Current (OUT15 ~ 0) | I_{OUT} | 40 | mA |
| Output Voltage (OUT15 ~ 0) | V_{OUT} | -0.3 ~ 20 | V |
| Clock Frequency | F_{DCK} | 30 | MHz |
| GND Pin Current | F_{GND} | 1000 | mA |
| Power Dissipation (on PCB) | P_D | 0.9 | W |
| Thermal Resistance (on PCB) | $R_{TH(i-a)}$ | 75 | $^{\circ}\text{C}/\text{W}$ |
| Operating Temperature | T_{OPR} | -40 ~ +85 | $^{\circ}\text{C}$ |
| Storage Temperature | T_{STG} | -55 ~ +150 | $^{\circ}\text{C}$ |

Note: Absolute maximum ratings are those values beyond which the device could be permanently damaged. Absolute maximum ratings are stress ratings only and functional device operation is not implied.

■ RECOMMENDED OPERATING CONDITIONS

| PARAMETER | SYMBOL | TEST CONDITIONS | MIN | TYP | MAX | UNIT |
|---------------------------------|-----------|--------------------------------------|---------------------|-------|---------------------|------|
| Supply Voltage | V_{DD} | | 3.3 | 5.0 | 5.5 | V |
| Output Voltage (OUT15 ~ 0) | V_{OUT} | I_{OUT} off | | | 20 | V |
| | | I_{OUT} on | 0.7 | | $0.5 \times V_{DD}$ | V |
| Output Current | I_{OUT} | OUT15 ~ 0 | 2 | | 40 | mA |
| | I_{OH} | $V_{OH}=V_{DD}-0.2\text{V}$ | | -0.66 | | |
| | I_{OL} | $V_{OL}=0.2\text{V}$ | | 2.0 | | |
| Input Voltage (DAI/ENB/LAT/DCK) | V_{IH} | $V_{DD}=3.3\text{V}\sim 5.5\text{V}$ | $0.7 \times V_{DD}$ | | V_{DD} | V |
| | V_{IL} | | 0 | | $0.3V_{DD}$ | |

■ ELECTRICAL CHARACTERISTICS ($V_{DD}=5.0\text{V}$)

| PARAMETER | SYMBOL | TEST CONDITIONS | MIN | TYP | MAX | UNIT |
|---------------------------------|---------------------------|--------------------------------------|-------------------------------------------------------------|-----------|---------------------|---------------|
| Supply Voltage | V_{DD} | | 4.5 | 5.0 | 5.5 | V |
| Sustaining Voltage At OUT Ports | V_{OUT} | OUT15 ~ 0 | | | 20 | V |
| Output Leakage Current | I_{LEAK} | $V_{OUT}=20\text{V}$ | | | 1 | μA |
| Input Voltage | "H" level | Logic Level | $0.7 \times V_{DD}$ | | V_{DD} | V |
| | "L" level | | 0 | | $0.3 \times V_{DD}$ | |
| DAO Voltage | V_{OH} | $I_{OH}=-0.66\text{mA}$ | $V_{DD}-0.2$ | | | V |
| | V_{OL} | $I_{OL}=1.0\text{mA}$ | | | 0.2 | |
| Output Current Accuracy | I_{CS} | I_{OSC} | $V_{OUT}=1.0\text{V}$, $R_{EXT}=2045\Omega$ | ± 3.0 | | % |
| Output Current Vs. | Output Voltage Regulation | $\% \Delta V_{OUT}$ | $R_{EXT}=2045\Omega$, $V_{OUT}=1\text{V}\sim 2\text{V}$ | | ± 0.1 | %V |
| | Supply Voltage Regulation | $\% \Delta V_{DD}$ | $R_{EXT}=2045\Omega$, $V_{DD}=4.5\text{V}\sim 5.5\text{V}$ | | ± 1 | |
| Supply Current | $I_{DD\ OFF1}$ | R_{EXT} open, OUT15 ~ 0 off | | 2.1 | 3.1 | mA |
| | $I_{DD\ OFF2}$ | $R_{EXT}=2045\Omega$, OUT15 ~ 0 off | | 6.2 | | |
| | $I_{DD\ ON}$ | $R_{EXT}=2045\Omega$, OUT15 ~ 0 on | | 7.1 | | |

■ ELECTRICAL CHARACTERISTICS ($V_{DD}=3.3V$)

| PARAMETER | | SYMBOL | TEST CONDITIONS | MIN | TYP | MAX | UNIT |
|---------------------------------|---------------------------|---------------------|--------------------------------------------|---------------------|-----------|---------------------|---------|
| Supply Voltage | | V_{DD} | | 3.0 | 3.3 | 3.6 | V |
| Sustaining Voltage At OUT Ports | | V_{OUT} | OUT15 ~ 0 | | | 20 | V |
| Output Leakage Current | | I_{LEAK} | $V_{OUT}=20V$ | | | 1 | μA |
| Input Voltage | "H" level | V_{IH} | Logic Level | $0.7 \times V_{DD}$ | | V_{DD} | V |
| | "L" level | V_{IL} | | 0 | | $0.3 \times V_{DD}$ | |
| DAO Voltage | | V_{OH} | $I_{OH}=-0.66mA$ | $V_{DD}-0.2$ | | | V |
| | | V_{OL} | $I_{OL}=1.0mA$ | | | 0.2 | |
| Output Current Accuracy | ICs | I_{OSC} | $V_{OUT}=1.0V, R_{EXT}=2045\Omega$ | | ± 3.0 | | % |
| Output Current Vs. | Output Voltage Regulation | $\%/\Delta V_{OUT}$ | $R_{EXT}=2045\Omega, V_{OUT}=1V\sim 2V$ | | | ± 0.1 | %V |
| | Supply Voltage Regulation | $\%/\Delta V_{DD}$ | $R_{EXT}=2045\Omega, V_{DD}=3.0V\sim 3.6V$ | | | ± 1 | |
| Supply Current | | I_{DD_OFF1} | R_{EXT} open, OUT15 ~ 0 off | | 2.1 | 3.1 | mA |
| | | I_{DD_OFF2} | $R_{EXT}=2045\Omega, OUT15 \sim 0$ off | | 6.2 | | |
| | | I_{DD_ON} | $R_{EXT}=2045\Omega, OUT15 \sim 0$ on | | 7.1 | | |

■ SWITCHING CHARACTERISTICS ($V_{DD}=5.0V$)

| PARAMETER | | SYMBOL | TEST CONDITIONS | MIN | TYP | MAX | UNIT |
|-----------------------------------|----------------|------------|------------------------------------------------------------------------------------|-----|-----|-----|------|
| Delay Response Time (Low to High) | DCK to DAO | t_{pLH} | $R_{EXT}=872\Omega, V_{IH}=V_{DD}, V_{IL}=0, V_{LED}=5.0V, R_L=47\Omega, C_L=12pF$ | | 33 | | ns |
| | LAT to OUT15~0 | t_{pLH1} | | | 53 | | |
| | ENB to OUT15~0 | t_{pLH2} | | | 52 | | |
| Delay Response Time (High to Low) | DCK to DAO | t_{pHL} | | | 23 | | |
| | LAT to OUT15~0 | t_{pHL1} | | | 54 | | |
| | ENB to OUT15~0 | t_{pHL2} | | | 53 | | |
| Output Rise Time Of OUT Ports | | t_{or} | | | 45 | | |
| Output Fall Time Of OUT Ports | | t_{of} | | | 44 | | |

■ SWITCHING CHARACTERISTICS ($V_{DD}=3.3V$)

| PARAMETER | | SYMBOL | TEST CONDITIONS | MIN | TYP | MAX | UNIT |
|-----------------------------------|----------------|------------|------------------------------------------------------------------------------------|-----|-----|-----|------|
| Delay Response Time (Low to High) | DCK to DAO | t_{pLH} | $R_{EXT}=872\Omega, V_{IH}=V_{DD}, V_{IL}=0, V_{LED}=5.0V, R_L=47\Omega, C_L=12pF$ | | 34 | | ns |
| | LAT to OUT15~0 | t_{pLH1} | | | 55 | | |
| | ENB to OUT15~0 | t_{pLH2} | | | 54 | | |
| Delay Response Time (High to Low) | DCK to DAO | t_{pHL} | | | 26 | | |
| | LAT to OUT15~0 | t_{pHL1} | | | 56 | | |
| | ENB to OUT15~0 | t_{pHL2} | | | 55 | | |
| Output Rise Time Of OUT Ports | | t_{or} | | | 47 | | |
| Output Fall Time Of OUT Ports | | t_{of} | | | 46 | | |

■ TEST CRICUIT FOR SWITCHING CHARACTERISTICS

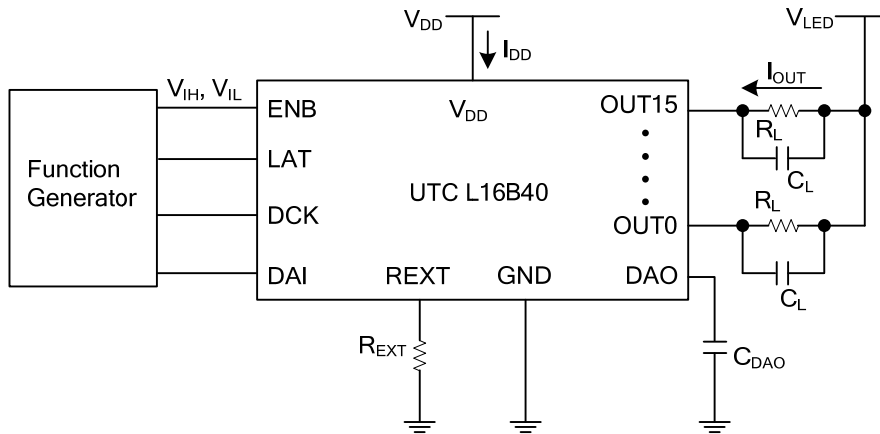

■ TIMING WAVEFORM

1. DCK, DAI, DAO, LAT, ENB, OUT15:0

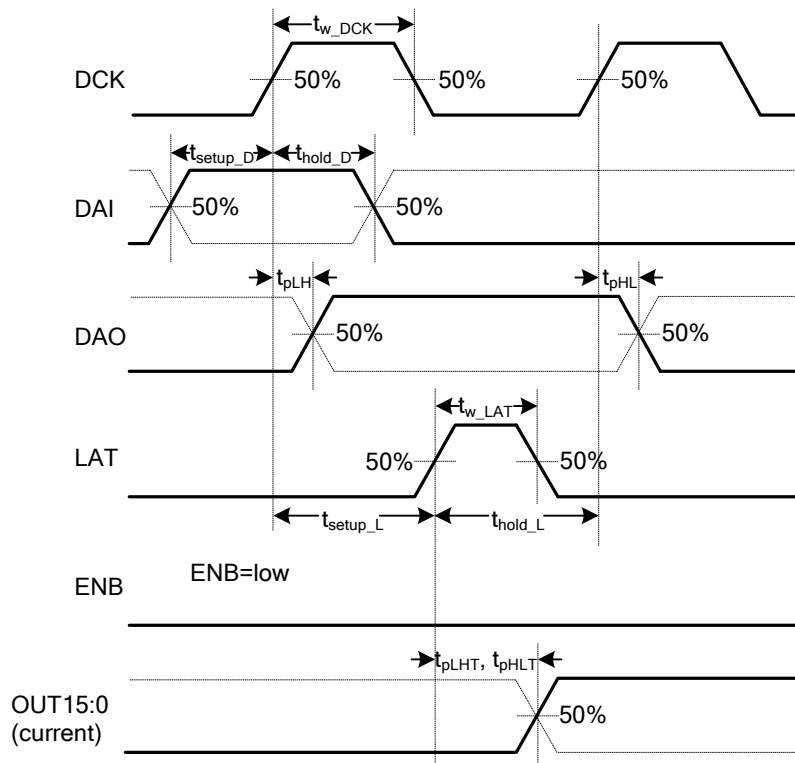

2. ENB, OUT15:0

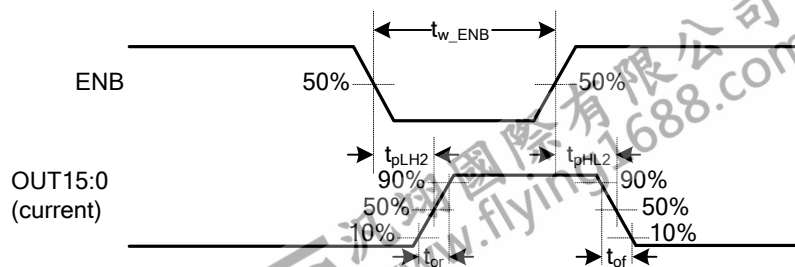

■ SEQUENCE DIAGRAM

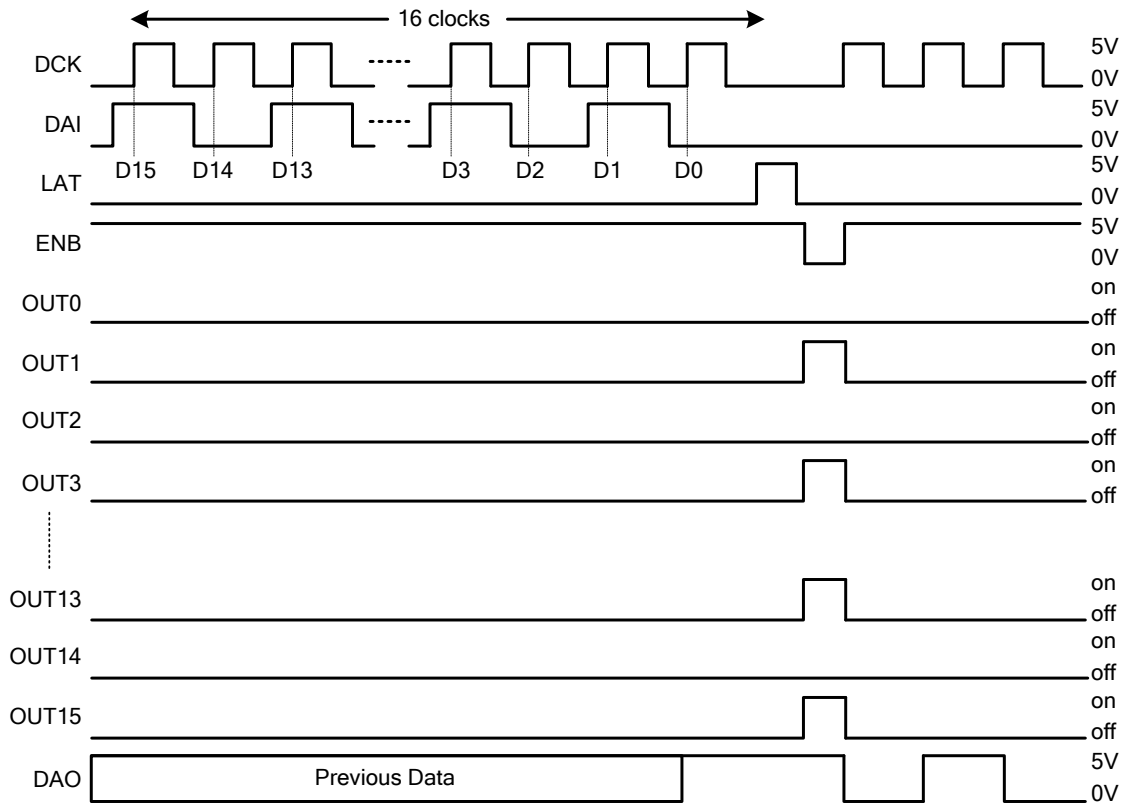

■ TYPICAL APPLICATION CIRCUIT

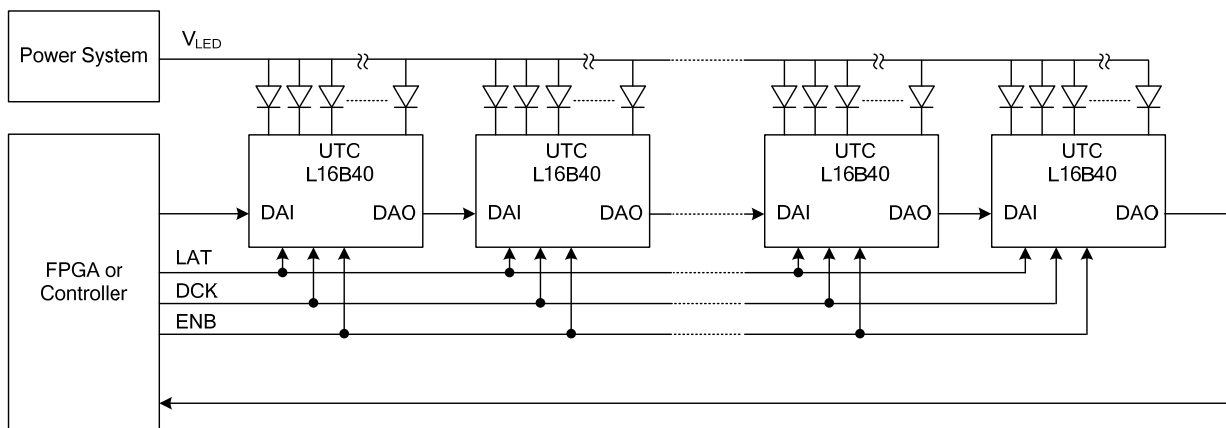

UTC assumes no responsibility for equipment failures that result from using products at values that exceed, even momentarily, rated values (such as maximum ratings, operating condition ranges, or other parameters) listed in products specifications of any and all UTC products described or contained herein. UTC products are not designed for use in life support appliances, devices or systems where malfunction of these products can be reasonably expected to result in personal injury. Reproduction in whole or in part is prohibited without the prior written consent of the copyright owner. The information presented in this document does not form part of any quotation or contract, is believed to be accurate and reliable and may be changed without notice.