



## L2572

## LINEAR INTEGRATED CIRCUIT

### WIDEBAND PLL FM DEMODULATOR

#### DESCRIPTION

As a wideband PLL FM demodulator, the UTC L2572 is intended for application in satellite tuners primarily.

The device includes all the necessary elements, with external oscillator sustaining network and the exception of loop feedback components, to form a PLL system operating at frequencies up to 800MHz completely.

An AFC with window adjust (whose output signal can be used to correct for any frequency drift at the head end local oscillator) is provided.

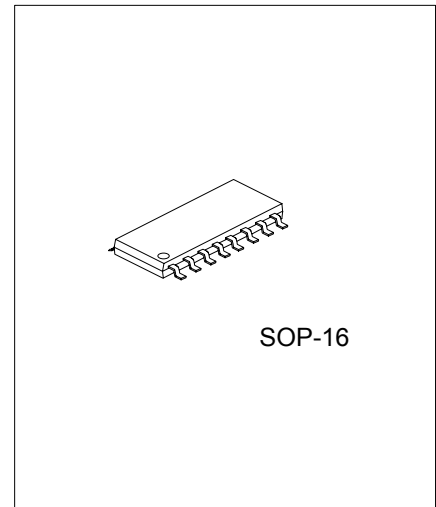

SOP-16

\*Pb-free plating product number: L2572L

#### FEATURES

- \* Constant voltage and constant current control
- \* Single chip PLL system for wideband FM demodulation
- \* Simple low component count application
- \* Allows for application of threshold extension
- \* Fully balanced low radiation design
- \* High operating input sensitivity
- \* Improved VCO stability with variations in supply or temperature
- \* AGC detect and bias adjust
- \* 75Ω video output drive with low distortion levels
- \* Dynamic self biasing analog AFC
- \* Full ESD Protection

#### ORDERING INFORMATION

Ordering Number		Package	Packing
Normal	Lead Free Plating		
L2572-S16-R	L2572L-S16-R	SOP-16	Tape Reel
L2572-S16-T	L2572L-S16-T	SOP-16	Tube

<p>L2572L-S16-R</p> <p>(1) Packing Type (2) Package Type (3) Lead Plating</p>	<p>(1) R: Tape Reel, T: Tube (2) S16: SOP-16 (3) L: Lead Free Plating, Blank: Pb/Sn</p>
---	---

### ■ PIN CONFIGURATION

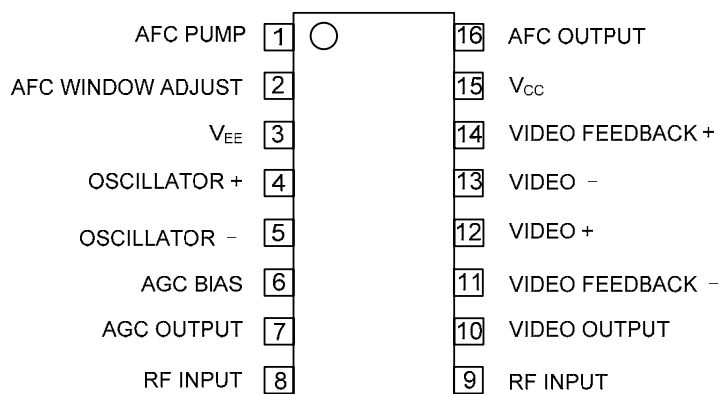

### ■ PIN DESCRIPTION

PIN NO.	PIN NAME	I/O	DESCRIPTION
1	AFC PUMP	I	Current pump, integrating the signal pulses into a DC voltage
2	AFC WINDOW ADJUST	I	Set the AFC deadband voltages corresponding the frequency
3	V <sub>EE</sub>		GND
4	OSCILLATOR+	I	Oscillator positive signal
5	OSCILLATOR-	I	Oscillator negative signal
6	AGC BIAS	I	Set the AGC bias
7	AGC OUTPUT	O	Output AGC DC voltage
8	RF INPUT	I	Input signal
9	RF INPUT	I	Input signal
10	VIDEO OUTPUT	O	Output video signal
11	VIDEO FEEDBACK-	I	Feedback the video negative signal
12	VIDEO+	O	Video positive signal
13	VIDEO-	O	Video negative signal
14	VIDEO FEEDBACK+	I	Feedback the video positive signal
15	V <sub>CC</sub>		Input V <sub>CC</sub>
16	AFC OUTPUT	O	Output AFC DC voltage

■ BLOCK DIAGRAM

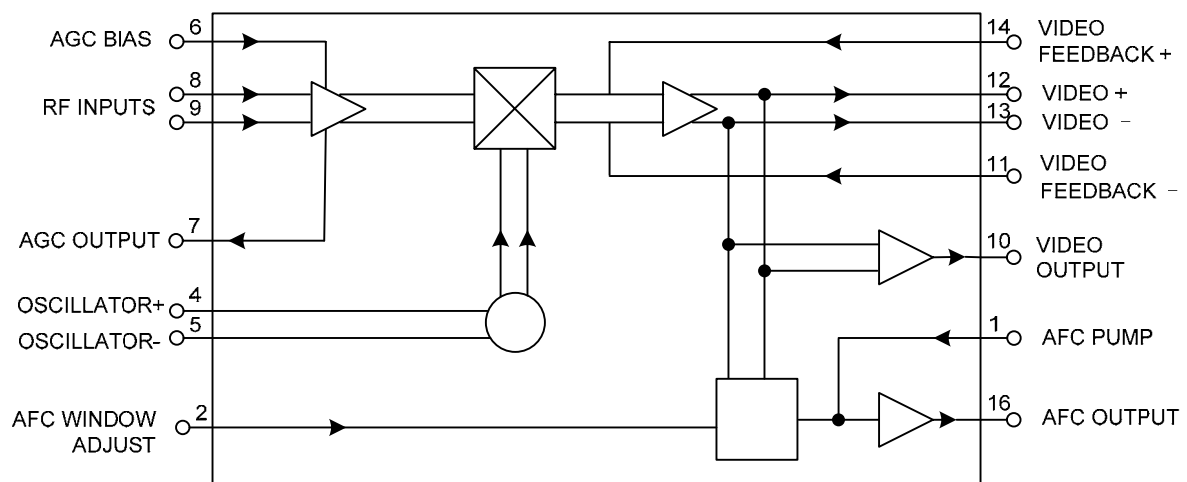

FLYING 飛翹國際有限公司  
[www.flying1688.com](http://www.flying1688.com)

## TEST CONFIGURATION

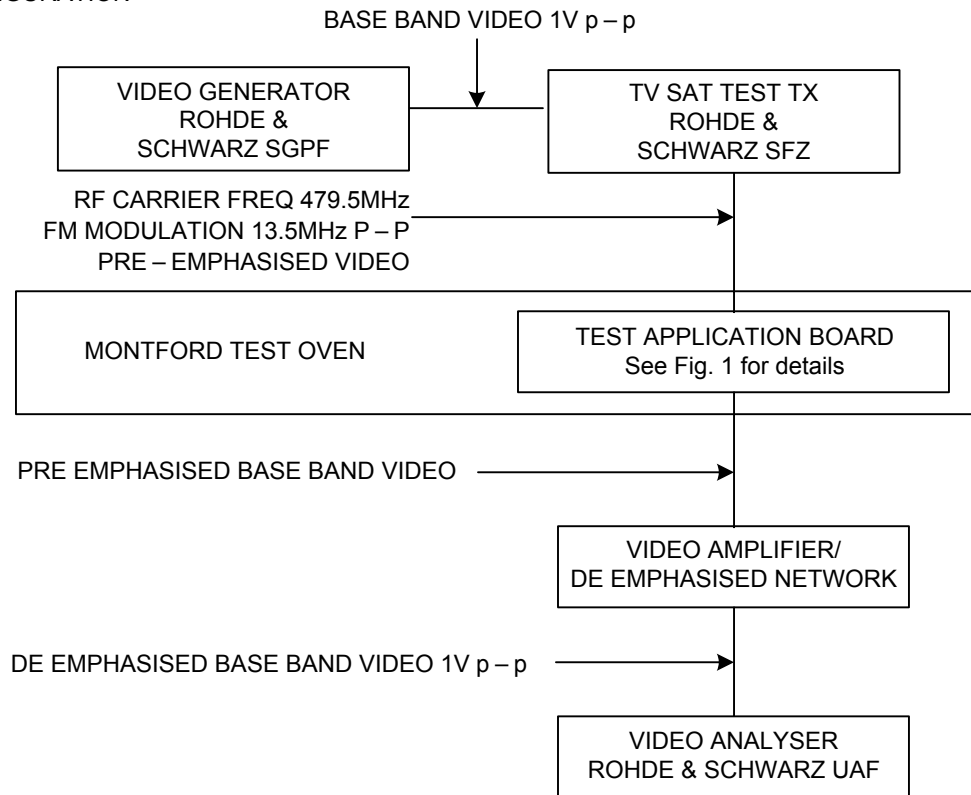

Using the above test configuration the video drive characteristics measurements were made. In the Electrical Characteristics Table the maximum figures recorded coincide with extremes of supply voltage and high temperatures. There's no adjustment to the recorded figures has been made to compensate for the effects of temperature on the external components of the application test board, in the varactor diodes particularly. Attention to temperature compensation of the external circuitry will result in performance figures closer to the stated typical figures if operation of the device at high ambient temperatures is envisaged.

### ■ ABSOLUTE MAXIMUM RATINGS (V<sub>EE</sub>=0V)

PARAMETER	SYMBOL	RATINGS	UNIT
Supply Voltage	V <sub>CC</sub>	-0.3~7	V
RF Input Voltage	V <sub>IN(RF)</sub>	2.5	V <sub>P-P</sub>
RF Input DC Offset	V <sub>IN RF(OFF)</sub>	-0.3~V <sub>CC</sub> +0.3	V
Oscillator ± DC Offset	V <sub>OSC(OFF)</sub>	-0.3~V <sub>CC</sub> +0.3	V
Video ± DC Offset	V <sub>VDO(OFF)</sub>	-0.3~V <sub>CC</sub> +0.3	V
Video Feedback ± DC Offset		-0.3~V <sub>CC</sub> +0.3	V
Video Output DC Offset		-0.3~V <sub>CC</sub> +0.3	V
AFC Pump DC Offset	V <sub>AFC(OFF)</sub>	-0.3~V <sub>CC</sub> +0.3	V
AFC Disable DC Offset		-0.3~V <sub>CC</sub> +0.3	V
AFC Deadband DC Offset		-0.3~V <sub>CC</sub> +0.3	V
AGC Bias DC Offset	V <sub>AGC(OFF)</sub>	-0.3~V <sub>CC</sub> +0.3	V
AGC Output DC Offset		-0.3~V <sub>CC</sub> +0.3	V
Power Dissipation (at 5.5V)	P <sub>D</sub>	250	mW
ESD Protection - Pin 1 to 15	ESD	2	kV
ESD Protection - Pin 16		1.7	kV
Junction Temperature	T <sub>J</sub>	150	°C
Storage Temperature	T <sub>STG</sub>	-55~125	°C

Note: Absolute maximum ratings are those values beyond which the device could be permanently damaged. Absolute maximum ratings are stress ratings only and functional device operation is not implied.

### ■ THERMAL DATA

Parameter	SYMBOL	RATINGS	Unit
Junction to Ambient	Θ <sub>JA</sub>	111	°C/W
Junction to Case	Θ <sub>JC</sub>	41	°C/W

### ■ ELECTRICAL CHARACTERISTICS

(T<sub>a</sub> = -20°C~+80°C, V<sub>CC</sub> = +4.5V ~ +5.5V. Either design or production test guarantee the electrical characteristics. Unless otherwise stated they apply within the specified ambient temperature and supply voltage.)

PARAMETER	SYMBOL	CONDITIONS	MIN	TYP	MAX	UNIT
Supply Current	V <sub>CC</sub>			36	40	mA
Operating Frequency	F <sub>OPR</sub>		300		800	MHz
Input Sensitivity		Preamplifier limiting		-40		dBm
Input Overload			0			dBm
VCO Sensitivity (dF/dV)		Refer to Fig. 1	25	32	39	MHz/V
VCO linearity		Refer to Fig. 1 with 13.5MHz p-p deviation		25		%
VCO Supply Stability		See note 5		2.0		MHz/V
VCO Temperature Stability		See note 5		20		KHz/°C
Phase Detector Gain		Differential loop filter Single ended loop filter		0.5 0.25		V/rad
Loop Amplifier Input Impedance	R <sub>IN</sub>		450	570	700	Ω
Loop Amplifier Output Impedance	R <sub>OUT(LOOP)</sub>			25		Ω
Loop Amplifier Open Loop Gain				38		dB
Loop Amplifier Gain Bandwidth Product	B <sub>W</sub>			240		MHz
Loop Amplifier Output Swing					1.2	Vp-p
Video Drive Output Impedance	R <sub>OUT(VIDEO)</sub>		55	75	95	Ω

■ ELECTRICAL CHARACTERISTICS(Cont.)

PARAMETER	SYMBOL	CONDITIONS	MIN	TYP	MAX	UNIT
<b>VIDEO DRIVE</b>						
Luminance Nonlinearity		1K $\Omega$ load, See note 3 and 4		1.9	5	%
Differential Gain		75K $\Omega$ load, See note 3 and 4		0.5	2.5	%
Differential Phase		75K $\Omega$ load, See note 3 and 4		1.0	3	Degree
Intermodulation		See notes 1, 3 and 4			-40	dB
Signal/noise		1K $\Omega$ load, See note 2 and 4	66	72		dB
Tilt		1K $\Omega$ load, See note 3 and 4		0.3	3	%
Baseline Distortion		1K $\Omega$ load, See note 3 and 4		0.4	2	%
AGC Output Current	$I_{OUT}$	Maximum load voltage drop 2V	10		400	$\mu$ A
AGC Bias Current	$I_{BIAS}$		0		250	$\mu$ A
AFC Window Current		400 $\mu$ A gives 1.5V deadband window	0		400	$\mu$ A
AFC Charge Pump Current				50		$\mu$ A
AFC Leakage Current	$I_{LEAK}$	With charge pump disabled			10	$\mu$ A
AFC Output Saturation Voltage	$V_{O(SAT)}$	AFC output enabled			0.4	V

Note 1. Input modulation's product  $f_1$  at 4.43MHz, 13.5MHz p-p deviation and  $f_2$  at 6MHz p-p deviation, (PAL chroma and sound subcarriers).

- To output rms noise in 6MHz bandwidth with no input modulation, ratio of output video signal with input modulation at 1MHz, 13.5MHz p-p deviation.
- Output voltage is 600mV pk-pk and input test signal pre-emphasised video 13.5MHz p-p deviation.
- See page 4
- Assuming ambient temperature of +20°C and operating frequency of 479.5MHz set with  $V_{CC}$  @ 5.0V. Only applies to application shown in Fig. 1 also refer to Fig. 4.

APPLICATION CIRCUIT

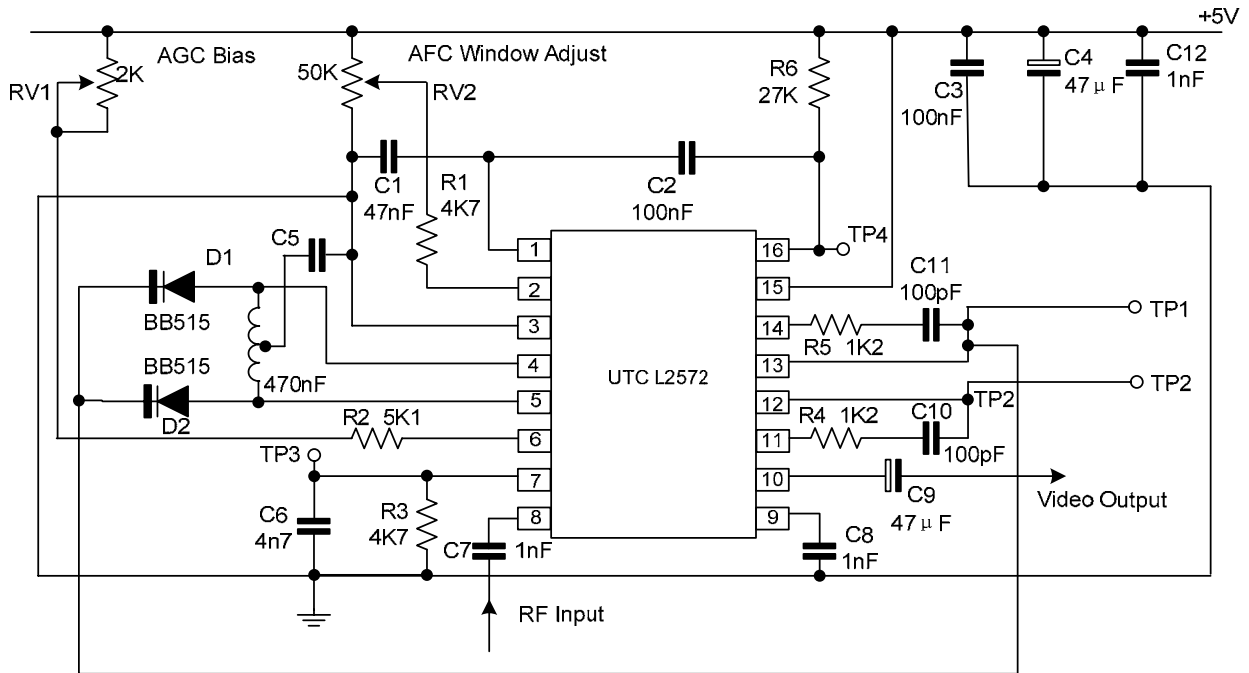

Fig. 1 Application Circuit

 汎翔國際有限公司  
[www.flying1688.com](http://www.flying1688.com)

## ■ FUNCTIONAL DESCRIPTION

The UTC L2572 is optimized for application in satellite receiver systems and requiring a minimum external component count is a wideband PLL FM demodulator. It includes all the elements required to construct a phase locked loop circuit, with the exception of an AFC detector circuit for generation of error signal to correct for any frequency drift in the outdoor unit local oscillator, and tuning components for the local oscillator contains a block diagram and Fig. 1 contains the typical application.

Fig. 2-1 contains the internal pin connections

In applications the second satellite IF frequency of typically 479.5 or 402MHz is fed to the RF preamplifier normally, which depending on application and layout has a working sensitivity of typically -40 dBm. An RF level detect circuit, which generates an AGC signal that can be used for controlling the gain of the IF amplifier stages is contained in the preamplifier, so it can be maintaining a fixed level to the RF input of the UTC L2572, for optimum threshold performance. The AGC circuit's bias point can be adjusted to cater for device input power and variation in AGC line voltage requirement. Fig. 5 shows the typical AGC curves are shown in. That the device is recommended that be operated with an input signal between -30 and -35dBm. That can ensure optimum linearity and threshold performance, and when over the typical sensitivity of -40dBm can give a good safety margin.

The preamplifier's output is fed to the mixer section which is of balanced design for low radiation. In this stage the RF signal is mixed with which is generated by an on-board oscillator, the local oscillator frequency. The oscillator block is optimized for high linearity over the normal deviation range and uses an external varactor tuned sustaining network. Fig. 3 contains a typical frequency versus voltage characteristic for the oscillator. Fig.4 shows the typical stability that the loop output is designed to compensate for first order temperature variation effects.

The mixer's output is then fed to the loop amplifier around which feedback is applied to effect loop transfer characteristic. Feedback could be applied either in single ended or differential mode; both modes should give the same loop response if the appropriate phase detector gains are assumed in calculating loop filters.

The loop amplifier drives a 75Ω output impedance buffer amplifier, which could be connected to a 75Ω load and used to drive a high input impedance stage giving greater linearity and approximately 6dB higher demodulated signal output level too.



INTERNAL CIRCUITS

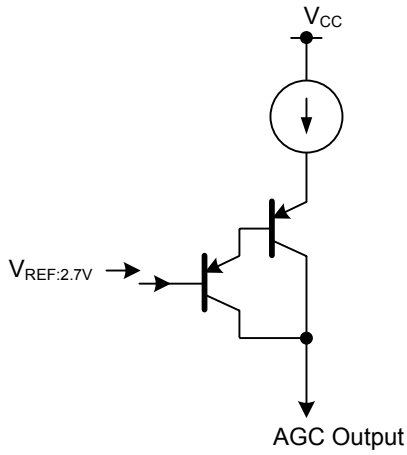

Fig. 2-1 AGC Output

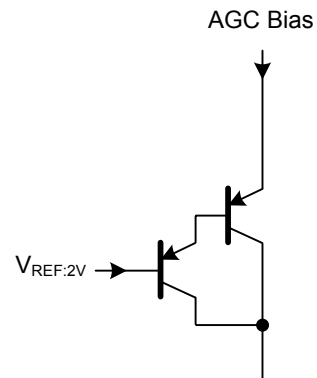

Fig. 2-2 AGC Bias Adjust

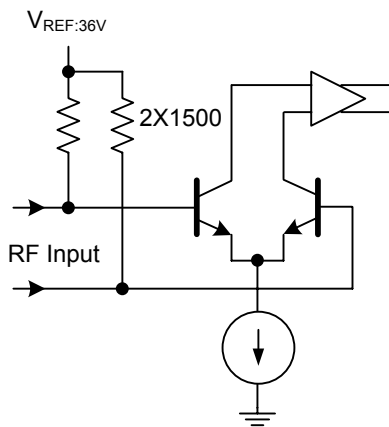

Fig. 2-3 RF Input

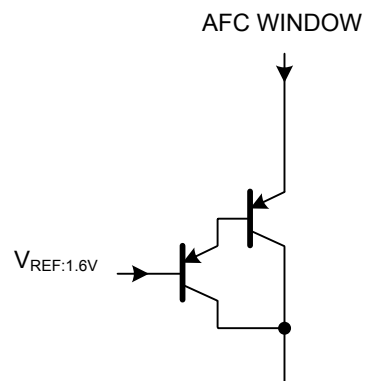

Fig. 2-4 AFC Window Adjust

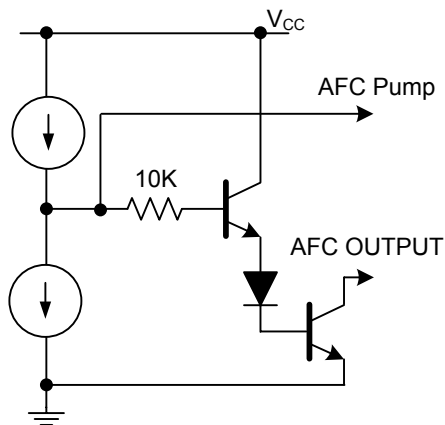

Fig. 2-5 AFC Output Stage

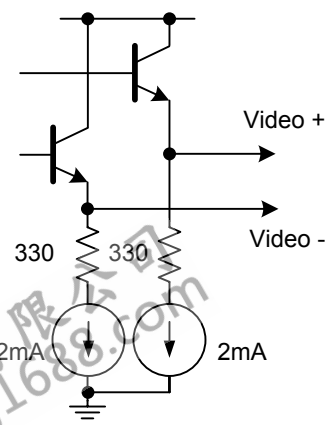

Fig. 2-6 Video Amp Output

INTERNAL CIRCUITS(Cont.)

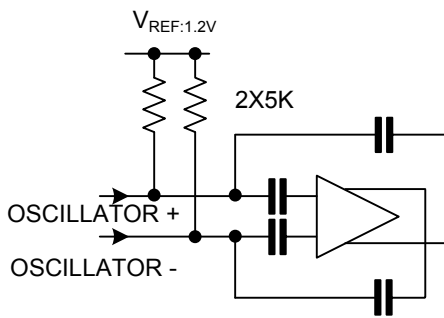

Fig. 2-7 Local Oscillator

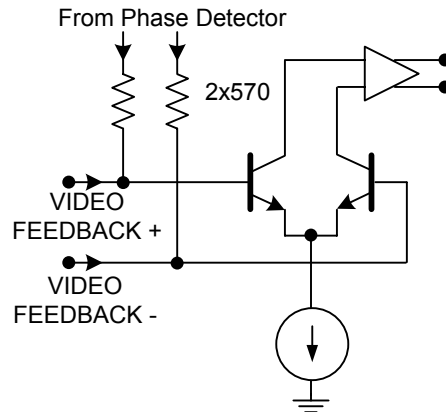

Fig. 2-8 Video amp feedback inputs

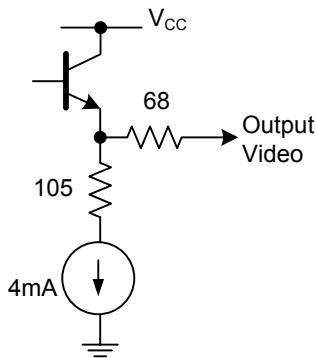

Fig. 2-9 Video Output Drive

FLYING 汎翔國際有限公司  
[www.flying1688.com](http://www.flying1688.com)

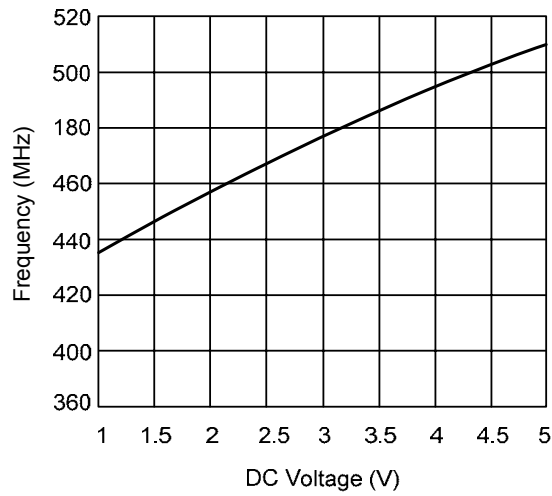

Fig. 3 Typical VCO Frequency vs. DC Control Voltage

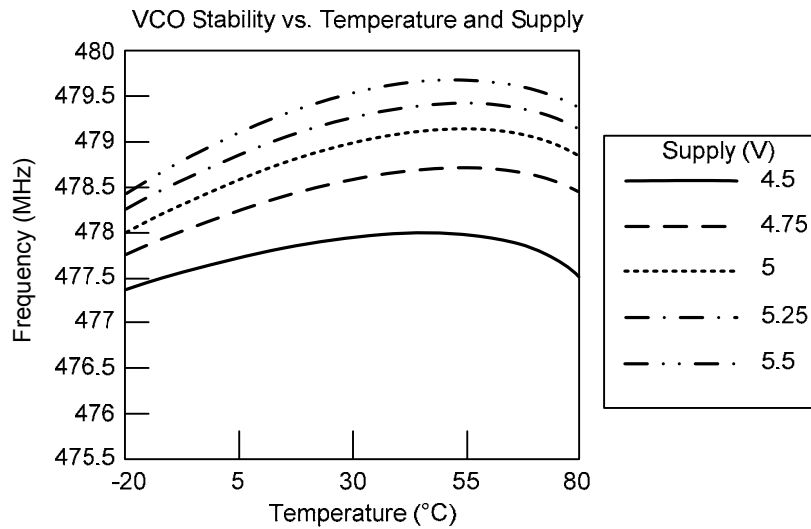

Fig. 4 VCO Centre Frequency Uncompensated Temperature Stability

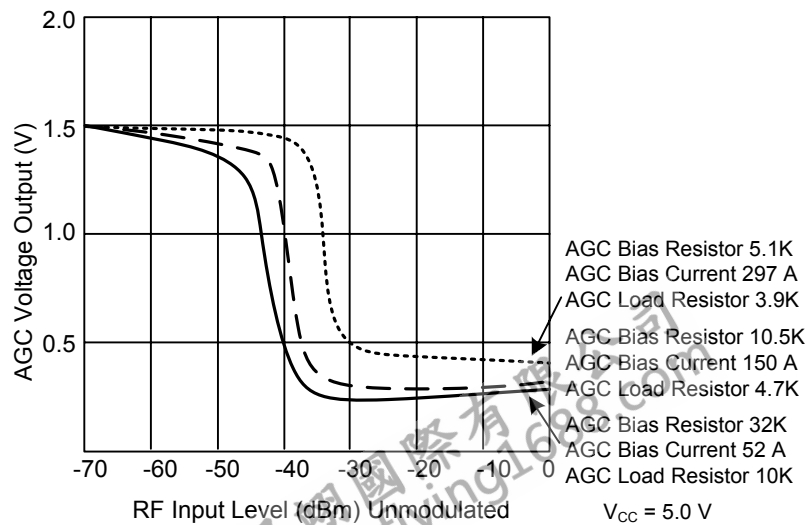
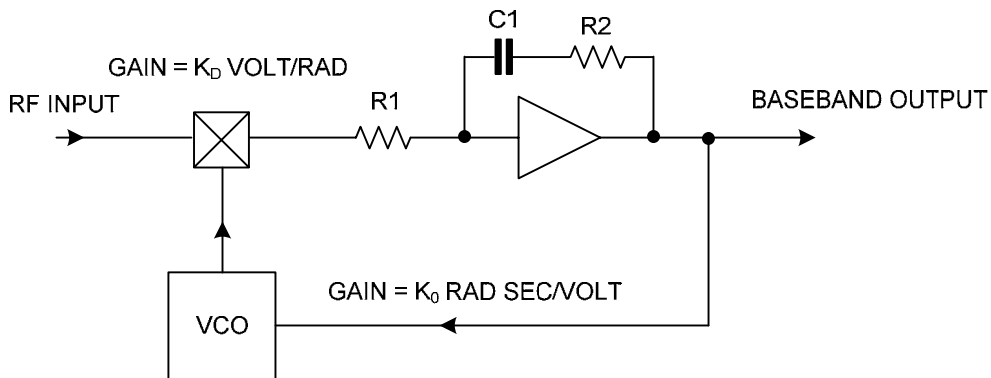

Fig.5 AGC Output Voltage for Differing Values of AGC Bias Resistor

■ DESIGN OF PLL LOOP PARAMETERS



The UTC L2572 is normally used as a type 1 second order loop and can be represented by the above diagram. For such a system the following parameters apply;

$$\tau_1 = C1.R1$$

$$\tau_2 = C1.R2$$

and

$$\tau_1 = \frac{K_0 K_D}{\omega_n^2}$$

$$\tau_2 = \frac{2\zeta}{\omega_n}$$

where:

$K_0$  is the VCO gain in radian seconds per volt

$K_D$  is the phase detector gain in volts per radian

$\omega_n$  is the natural loop bandwidth

$\zeta$  is the loop damping factor

R1 is loop amplifier input impedance

Note:  $K_0$  is dependant on sensitivity of VCO used.

$K_D = 0.25V/rad$  single ended,  $0.5V/rad$  differential

From these factors the loop 3dB bandwidth can be determined from the following expression;

$$\omega_{3dB}^2 = \omega_n^2 (2\zeta^2 + 1) \pm \omega_n^2 \sqrt{(2\zeta^2 + 1)^2 + 1}$$

Which approximates to  $\omega_{3dB} = 2\omega_n$  when  $\zeta = \frac{1}{\sqrt{2}}$

■ AFC FACILITY

An analog frequency error detect circuit, which generates DC voltage proportional to the integral of frequency error is contained in UTC L2572. As the incident RF is high then the AFC voltage increases, as low then the voltage decreases. ADC converts the AFC voltage can then be an to be read by the micro controller for frequency fine tuning.

Around the aligned frequency the AFC detect circuit contains a deadband centre. From zero window to approximately 25MHz width assuming an oscillator dF/dV of 15MHz/V the deadband can be adjusted. The AFC voltage does not integrate if the incident RF is within this window, except by component leakage.

With reference to Fig. 6; the demodulated video is fed to a dual comparator which can be compared with two reference voltages in normal operation, corresponding to the extremes of the deadband, or window. These voltages are variable and the window adjust input can set it.

Two digital outputs corresponding to voltages above or below the voltage window, or frequency above or below deadband can be produced by the comparators. These digital control signals can control a complimentary current source pump. The current signals are then fed to an amplifier's input. it is arranged as an integrator, so integrating the pulses into a DC voltage.

Both the current source and sink are disabled if the frequency is correctly aligned, therefore the DC output voltage can be constant. Due to component leakage there will be a small drift; the maximum drift can be calculated from here:

$$\frac{dV}{dt} = \frac{I}{2500.C} \quad \text{where} \quad I = \frac{V_{CC}}{R_{EXT}}, \quad C = C_{EXT}$$

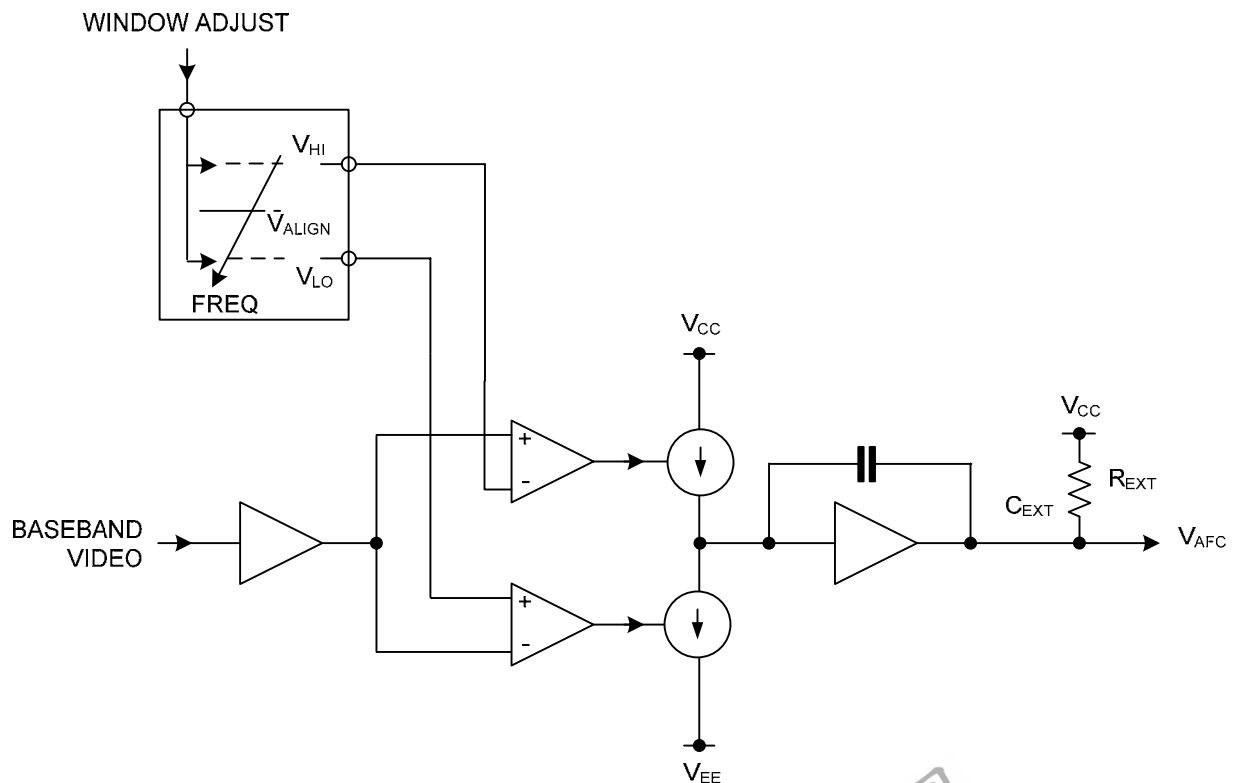

Fig. 6 AFC System Block Diagram

UTC assumes no responsibility for equipment failures that result from using products at values that exceed, even momentarily, rated values (such as maximum ratings, operating condition ranges, or other parameters) listed in products specifications of any and all UTC products described or contained herein. UTC products are not designed for use in life support appliances, devices or systems where malfunction of these products can be reasonably expected to result in personal injury. Reproduction in whole or in part is prohibited without the prior written consent of the copyright owner. The information presented in this document does not form part of any quotation or contract, is believed to be accurate and reliable and may be changed without notice.