



L4075

Preliminary

CMOS IC

40V LED DRIVER WITH INTERNAL SWITCH

DESCRIPTION

The UTC **L4075** is a continuous conduction mode inductive step-down converter, designed for driving single or multiple series connected LEDs efficiently from a voltage source higher than the total LEDs chain voltage. The chip operates from an input supply between 6V and 40V and provides an externally adjustable output current of up to 400mA. Depending upon supply voltage and external components, this can provide up to 30W of output power.

The UTC **L4075** includes an integrated output switch and a high-side output current sensing circuit, which uses an external resistor to set the nominal average output current.

Output current can be adjusted linearly by applying an external control signal to the ADJ pin. The ADJ pin will accept either a DC voltage dimming or a wide range of pulsed dimming. This will provide either a continuous or a gated output current.

Applying a voltage of 0.2V or lower to the ADJ pin can turn the output off and switch the chip into a low current standby state.

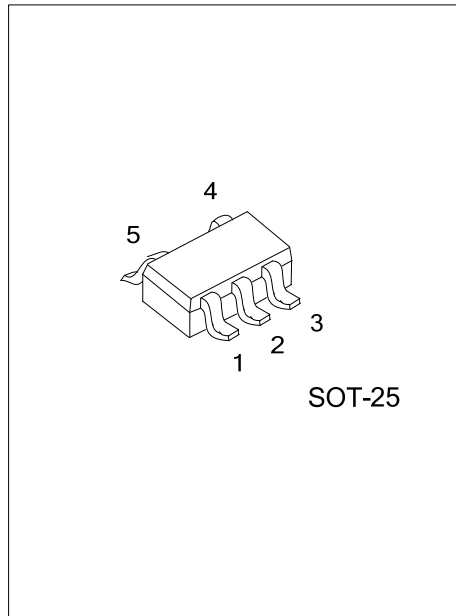

FEATURES

- * 6V~40V input voltage range
- * Simple low parts count
- * Internal 40V power switch
- * High efficiency up to 95%
- * Typical 5% output current accuracy
- * Single pin on/off and brightness control using DC voltage or PWM
- * Up to 1MHz switching frequency
- * Protection features:
 - Open-circuit LED Protection
 - Thermal shutdown Protection

ORDERING INFORMATION

Ordering Number		Package	Packing
Lead Free	Halogen Free		
L4075L-AF5-R	L4075G-AF5-R	SOT-25	Tape Reel

<p>L4075G-AF5-R</p> <ul style="list-style-type: none"> (1) Packing Type (2) Package Type (3) Green Package 	<ul style="list-style-type: none"> (1) R: Tape Reel (2) AF5: SOT-25 (3) G: Halogen Free and Lead Free, L: Lead Free
---	--

MARKING

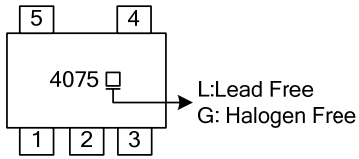

PIN CONFIGURATION

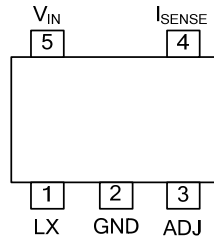

PIN DESCRIPTION

PIN NO.	PIN NAME	DESCRIPTION
1	LX	Drain of power switch
2	GND	Ground (0V)
3	ADJ	Multi-function On/Off and brightness control pin
4	I _{SENSE}	Current sense input
5	V _{IN}	Input voltage

BLOCK DIAGRAM

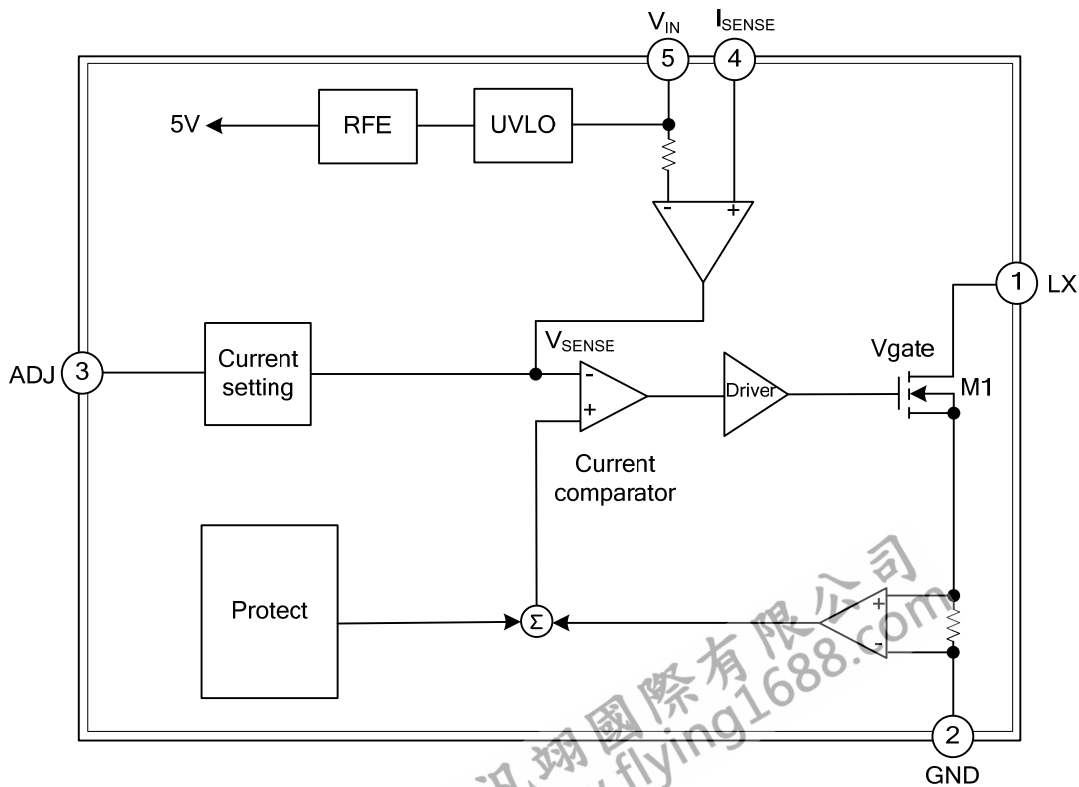

■ ABSOLUTE MAXIMUM RATING

PARAMETER	SYMBOL	RATINGS	UNIT
Input Voltage	V_{IN}	+50	V
I _{SENSE} Voltage	V_{ISENSE}	$V_{IN} > 5V$	$V_{IN} + 0.3 \sim V_{IN} - 5$
		$V_{IN} < 5V$	$V_{IN} + 0.3 \sim -0.3$
LX Output Voltage	V_{LX}	-0.3 ~ +50	V
Adjust Pin Input Voltage	V_{ADJ}	-0.3 ~ +6	V
Switch Output Current	I_{LX}	400	mA
Power Dissipation	P_D	370	mW
Operating Junction Temperature	T_J	150	°C
Operating Temperature Range	T_{OPR}	-40 ~ +85	°C
Storage Temperature Range	T_{STG}	-55 ~ +150	°C

Note: Absolute maximum ratings are those values beyond which the device could be permanently damaged.
Absolute maximum ratings are stress ratings only and functional device operation is not implied.

■ THERMAL CHARACTERISTICS

PARAMETER	SYMBOL	RATINGS	UNIT
Junction to Ambient	θ_{JA}	270	°C/W

■ ELECTRICAL CHARACTERISTICS ($V_{IN}=12V$, $T_{AMB}=25^{\circ}C$ unless otherwise stated) (Note 1)

PARAMETER	SYMBOL	TEST CONDITIONS	MIN	TYP	MAX	UNIT
Input Voltage	V_{IN}		6		40	V
Quiescent Supply Current with Output Off	I_{INQOFF}	ADJ Pin Grounded	40	60	80	μA
Quiescent Supply Current with Output Switching	I_{INQON}	ADJ Pin Floating		450	600	μA
Mean Current Sense Threshold Voltage	V_{SENSE}			113		mV
Sense Threshold Hysteresis	$V_{SENSEHYS}$			± 15		%
I_{SENSE} Pin Input Current	I_{SENSE}	$V_{SENSE}=0.1V$		8	10	μA
Internal Reference Voltage	V_{REF}	Measured on ADJ Pin with Pin Floating		1.2		V
External Control Voltage Range On ADJ Pin for DC Brightness Control	V_{ADJ}		0.3		1.2	V
DC Voltage On ADJ Pin to Switch Chip from Active (On) State to Quiescent (Off) State	V_{ADJOFF}	V_{ADJ} Falling	0.15	0.2	0.25	V
DC Voltage On ADJ Pin to Switch Chip from Quiescent (Off) State to Active (On) State	V_{ADJON}	V_{ADJ} Rising	0.2	0.25	0.3	V
Resistance Between ADJ Pin and V_{REF}	R_{ADJ}			500		K Ω
Continuous LX Switch Current	I_{LXmean}			0.35		A
LX Switch Leakage Current	$I_{LX(leak)}$				1	μA
LX Switch "On" Resistance	R_{LX}			0.9	1.5	Ω
Minimum Switch "ON" Time	T_{ONMIN}	LX Switch "ON"		200		ns
Minimum Switch "OFF" Time	T_{OFFMIN}	LX Switch "OFF"		200		ns
Brightness Control Range at Low Frequency PWM Signal	$D_{PWM(LF)}$	PWM Frequency=100Hz, PWM Amplitude=5V, $V_{IN}=15V$, Driving 1LED, L=27 μH		1200:1		
Brightness Control Range at Low Frequency PWM Signal	$D_{PWM(HF)}$	PWM Frequency=10KHz, PWM Amplitude=5V, $V_{IN}=15V$, Driving 1LED, L=27 μH		13:1		
Operating Frequency	f_{LX}	ADJ Pin Floating L=100Mh (0.82 Ω) $I_{OUT}=350mA$ @ $V_{LED}=3.4V$ Driving 1 LED		154		KHz
Recommended Maximum Operating Frequency	f_{LXMAX}				1	MHz
Recommended Duty Cycle Range of Output Switch at f_{LXmax}	D_{LX}		0.3	0.7	0.9	
Internal Comparator Propagation Delay	T_{PD}			50		ns
Thermal Shutdown Temperature	T_{SD}			140		$^{\circ}C$
Thermal Shutdown Hysteresis	T_{SD-HYS}			20		$^{\circ}C$

Note: Production testing of the chip is performed at 25 $^{\circ}C$. Functional operation of the chip and parameters specified are guaranteed by design, characterization and process control in other temperature.

■ TYPICAL APPLICATION CIRCUIT

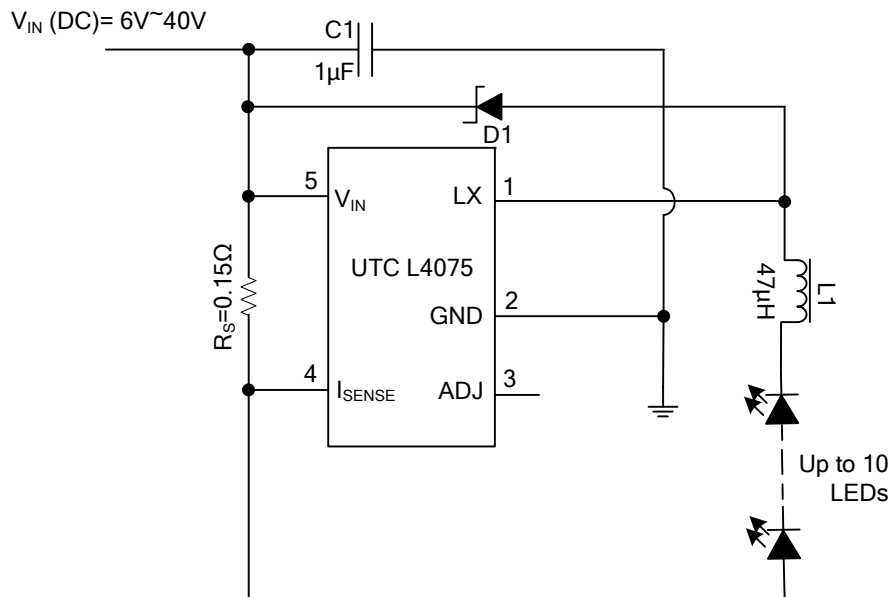

UTC assumes no responsibility for equipment failures that result from using products at values that exceed, even momentarily, rated values (such as maximum ratings, operating condition ranges, or other parameters) listed in products specifications of any and all UTC products described or contained herein. UTC products are not designed for use in life support appliances, devices or systems where malfunction of these products can be reasonably expected to result in personal injury. Reproduction in whole or in part is prohibited without the prior written consent of the copyright owner. UTC reserves the right to make changes to information published in this document, including without limitation specifications and product descriptions, at any time and without notice. This document supersedes and replaces all information supplied prior to the publication hereof.