



## LMH358

Preliminary

LINEAR INTEGRATED CIRCUIT

### LOW POWER DUAL OPERATIONAL AMPLIFIERS

#### DESCRIPTION

The UTC **LMH358** is low noise, high voltage, and high slew rate operational amplifier. This circuit consists of two independent, high gain, internally frequency compensated operational amplifiers.

The input common mode range of the UTC **LMH358** can be beyond the rails. The UTC **LMH358** are with rail-to-rails output voltage swing. The quiescent current is 500µA per amplifier.

The UTC **LMH358** also feature fast slewing and settle-times, as well as high output drive capability of 60mA (source/sink).

These features make these amplifiers ideal for use as reference buffers for TFT-LCD. Other applications include battery power, portable devices, and anywhere low power consumption is important.

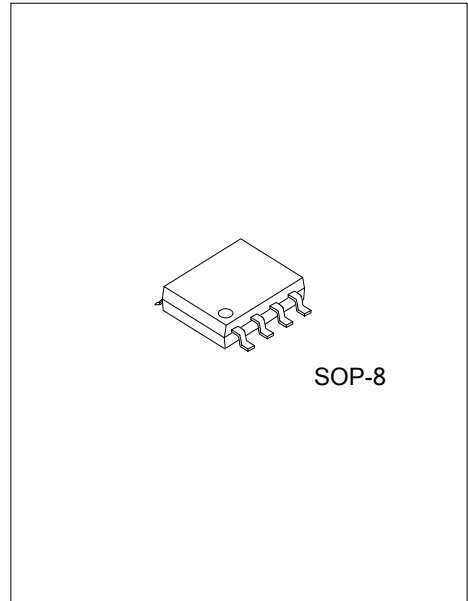

SOP-8

#### FEATURES

- \* Operates on 4.5V~16V supplies
- \* Input common voltage range beyond the rails
- \* Rail-to-Rail output voltage swing
- \* Low input offset voltage 3mV (Typical)
- \* High gain-bandwidth product 4MHz
- \* Low quiescent current: 500µA per amplifier
- \* Large DC voltage gain 100dB (Typical)
- \* High slew rate 1.3V/µs
- \* Unit-Gain stable

#### ORDERING INFORMATION

Ordering Number		Package	Packing
Lead Free	Halogen Free		
LMH358L-S08-R	LMH358G-S08-R	SOP-8	Tape Reel

<p>LMH358G-S08-R</p> <p>(1) Packing Type (2) Package Type (3) Green Package</p>	<p>(1) R: Tape Reel (2) S08: SOP-8 (3) G: Halogen Free and Lead Free, L: Lead Free</p>
---	--

#### MARKING

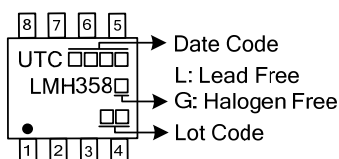

■ PIN CONFIGURATION

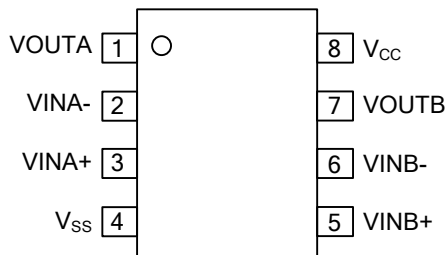

■ PIN DESCRIPTION

PIN NO.	PIN NAME	DESCRIPTION
1	VOUTA	Output of channel A
2	VINA-	Inverting input of channel A
3	VINA+	Non-Inverting input of channel A
4	V <sub>SS</sub>	Ground
5	VINB+	Non-Inverting input of channel B
6	VINB-	Inverting input of channel B
7	VOUTB	Output of channel B
8	V <sub>CC</sub>	Supply voltage

■ BLOCK DIAGRAM

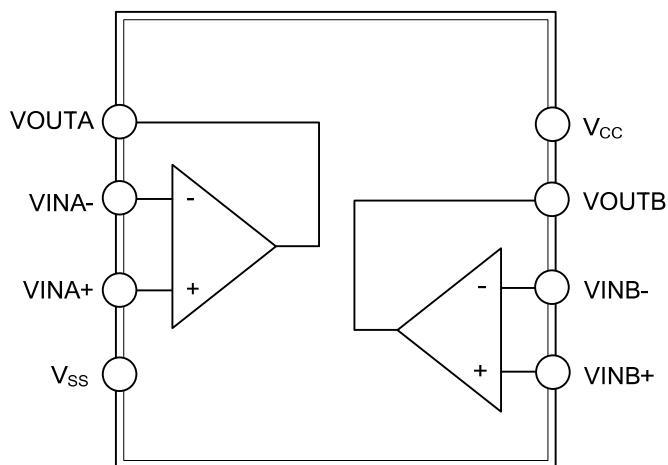

### ■ ABSOLUTE MAXIMUM RATING

PARAMETER	SYMBOL	RATINGS	UNIT
Supply Voltage	$V_{CC}$	18	V
Input Voltage IN+, IN-		$-0.3 \sim V_{CC} + 0.3$	V
Continuous Power Dissipation ( $T_A = +25^\circ\text{C}$ )	$P_D$	0.7	W
Operating Ambient Temperature Range	$T_A$	$-40 \sim +85$	$^\circ\text{C}$
Junction Temperature	$T_J$	+150	$^\circ\text{C}$
Storage Temperature	$T_{STG}$	$-65 \sim +150$	$^\circ\text{C}$
Reflow Temperature (Soldering, 10sec)	$T_R$	260	$^\circ\text{C}$

Note: Absolute maximum ratings are those values beyond which the device could be permanently damaged. Absolute maximum ratings are stress ratings only and functional device operation is not implied.

### ■ THERMAL CHARACTERISTICS

PARAMETER	SYMBOL	RATINGS	UNIT
Junction to Ambient	$\theta_{JA}$	170	$^\circ\text{C}/\text{W}$

### ■ ELECTRICAL CHARACTERISTICS

( $T_A = 25^\circ\text{C}$ ;  $V_{CC} = 5\text{V}$ ;  $V_{SS} = -5\text{V}$ ;  $C_L = 10\text{pF}$ ,  $R_L = 10\text{k}\Omega$  to  $0\text{V}$ ; unless otherwise specified.)

PARAMETER	SYMBOL	TEST CONDITIONS	MIN	TYP	MAX	UNIT
<b>Supplies</b>						
Supply Voltage Range (Note)	$V_{CC} - V_{SS}$		4.5		16	V
Supply Current	$I_{CC1}$	$V_O = 0\text{V}$ No Load (Per Amplifier)		0.5	0.75	mA
<b>DC Characteristics</b>						
Input Offset Voltage	$V_{IO}$			3	10	mV
Common Mode Voltage	$V_{CM}$	Inferred from CMRR Test	$V_{SS} - 0.5$		$V_{CC} + 0.5$	V
Input Bias Current	$I_B$	$V_{CM} = 0$		2	50	nA
Input Impedence				1		$\text{G}\Omega$
Open Loop Gain	$A_V$	$V_O = -4.5\text{V} \sim +4.5\text{V}$	80	105		dB
Output Voltage Swing High	$V_{OH}$		4.85	4.92		V
Output Voltage Swing Low	$V_{OL}$			-4.92	-4.85	V
Short Circuit Current	$I_{SC}$			$\pm 160$		mA
Output Current	$I_O$			$\pm 50$		mA
Power Supply Rejection Ratio	PSRR	$5\text{V} \leq V_{CC} \leq 16\text{V}$	60	85		dB
Common-Mode Rejection Ratio	CMRR	$V_{SS} \leq V_{CM} \leq V_{CC}$	50	80		dB
Channel Separation	CS	$f = 100\text{KHz}$		75		dB
Slew Rate	SR	$-4\text{V} \sim +4\text{V}$ 10%~90%		1.3		$\text{V}/\mu\text{S}$
Settle Time (to 0.1% $A_V = 1$ )		$V_O = 2\text{V}$ Step		450		nS
Bandwidth		$R_L = 10\text{K}\Omega$ $C_L = 10\text{pF}$		4		MHz
Phase Margin				50		degree

Note: Guaranteed by the Power-Supply Rejection Ratio (PSRR) test.

UTC assumes no responsibility for equipment failures that result from using products at values that exceed, even momentarily, rated values (such as maximum ratings, operating condition ranges, or other parameters) listed in products specifications of any and all UTC products described or contained herein. UTC products are not designed for use in life support appliances, devices or systems where malfunction of these products can be reasonably expected to result in personal injury. Reproduction in whole or in part is prohibited without the prior written consent of the copyright owner. The information presented in this document does not form part of any quotation or contract, is believed to be accurate and reliable and may be changed without notice.