



LS3718

CMOS IC

20-BIT SERIAL TO PARALLEL CONVERTER

DESCRIPTION

The UTC **LS3718** is a 20-bit serial to parallel converter utilizing CMOS Technology. It is incorporates control circuit, shift register, latch and driver into a single ship. It is suitable for MCU interface. The effective interface assignment of MPU is available as the connection between UTC **LS3718** and MPU is required only 4 lines.

The device is designed to operate up to 5MHz. When the serial data input to the DATA terminal and the data is output from parallel output buffer through serial in parallel out shift register and parallel data latches.

The data can through the shift register serial output to the SO terminal. Therefore the **UTC LS3718** can cascade connection to expand the output data number.

The hysteresis input circuit realizes wide noise margin and the high drive-ability output buffer (25mA) can drive LED directly.

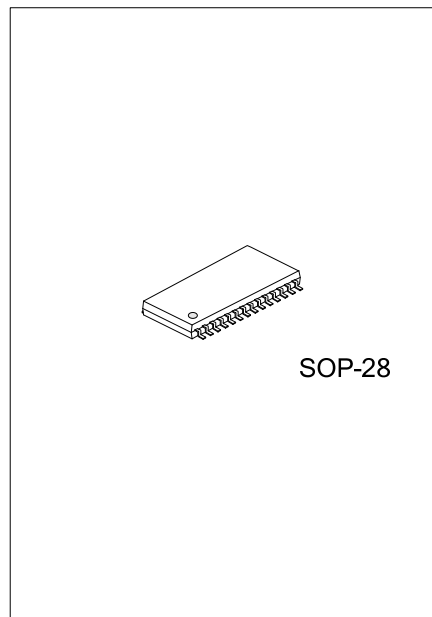

FEATURES

- * 20-Bit serial in parallel out
- * Cascade connection
- * Operating voltage 5V±10%
- * Hysteresis input 0.5V typ
- * Output current 25mA
- * Operating frequency 5MHz or more

ORDERING INFORMATION

Ordering Number	Package	Packing
LS3718G-S28-R	SOP-28	Tape Reel

<p>LS3718G-S28-R</p> <ul style="list-style-type: none"> (1) Packing Type (2) Package Type (3) Green Package 	<ul style="list-style-type: none"> (1) R: Tape Reel (2) S28: SOP-28 (3) G: Halogen Free and Lead Free
--	--

MARKING

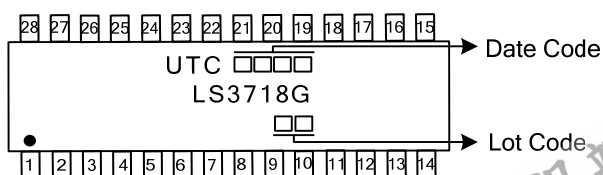

■ PIN CONFIGURATION

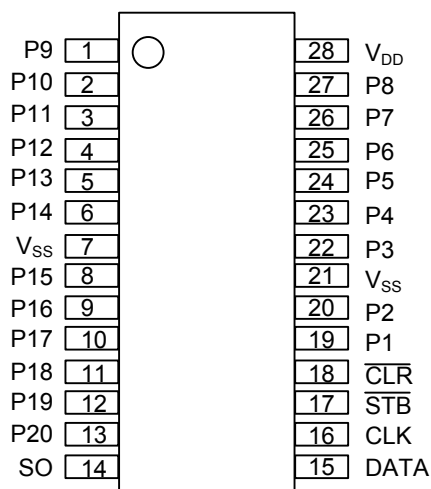

■ PIN DESCRIPTION

PIN NO	PIN NAME	I/O	DESCRIPTION
1	P9	O	Parallel Data Output Pin 9
2	P10	O	Parallel Data Output Pin 10
3	P11	O	Parallel Data Output Pin 11
4	P12	O	Parallel Data Output Pin 12
5	P13	O	Parallel Data Output Pin 13
6	P14	O	Parallel Data Output Pin 14
7	V _{SS}		GND
8	P15	O	Parallel Data Output Pin 15
9	P16	O	Parallel Data Output Pin 16
10	P17	O	Parallel Data Output Pin 17
11	P18	O	Parallel Data Output Pin 18
12	P19	O	Parallel Data Output Pin 19
13	P20	O	Parallel Data Output Pin 20
14	SO	O	Serial Data Output Pin
15	DATA	I	Serial Data Input Pin
16	CLK	I	Clock Signal Input Pin
17	STB	I	Data Strobe, Low Activated
18	CLR	I	Data Reset, Low Activated
19	P1	O	Parallel Data Output Pin 1
20	P2	O	Parallel Data Output Pin 2
21	V _{SS}		GND
22	P3	O	Parallel Data Output Pin 3
23	P4	O	Parallel Data Output Pin 4
24	P5	O	Parallel Data Output Pin 5
25	P6	O	Parallel Data Output Pin 6
26	P7	O	Parallel Data Output Pin 7
27	P8	O	Parallel Data Output Pin 8
28	V _{DD}		Power Supply

■ BLOCK DIAGRAM

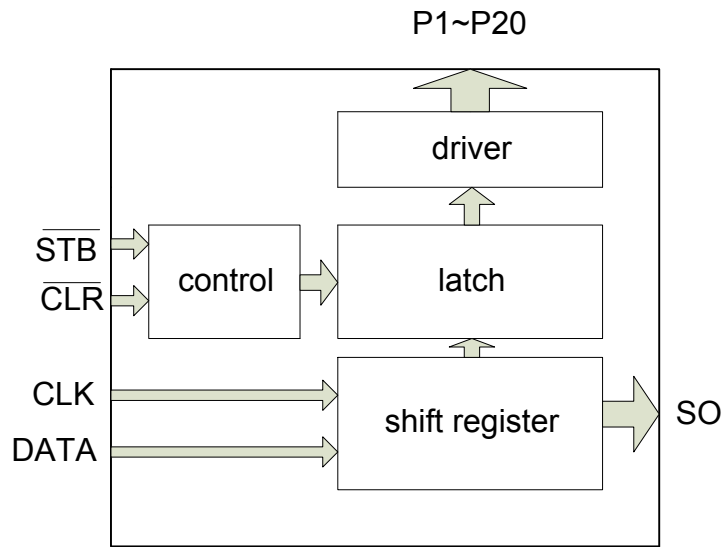

FLYING 汎翔國際有限公司
www.flying1688.com

■ ABSOLUTE MAXIMUM RATINGS (T_A=25°C, unless otherwise specified)

PARAMETER	SYMBOL	RATINGS	UNIT
Supply Voltage	V _{DD}	-0.5~+7.0	V
Input Voltage	V _{IN}	V _{SS} -0.5~V _{DD} +0.5	V
Output Voltage	V _{OUT}	V _{SS} -0.5~V _{DD} +0.5	V
Output Current	I _{OUT}	±25	mA
Power Dissipation	P _D	500	mW
Junction Temperature	T _J	+125	°C
Operating Temperature	T _{OPR}	-25 ~ +85	°C
Storage Temperature	T _{STG}	-40 ~ +150	°C

Note: Absolute maximum ratings are those values beyond which the device could be permanently damaged. Absolute maximum ratings are stress ratings only and functional device operation is not implied.

■ ELECTRICAL CHARACTERISTICS (V_{DD}=4.5~5.5V, V_{SS}=0V, T_A=25°C, unless otherwise specified)

PARAMETER	SYMBOL	TEST CONDITIONS	MIN	TYP	MAX	UNIT		
Operating Voltage	V _{DD}		4.5		5.5	V		
Operating Current	I _S	V _{IH} =V _{DD} , V _{IL} =V _{SS}			0.1	mA		
Input Leakage Current	I _{I(LEAK)}	V _{IN} =0~V _{DD}	-10		10	µA		
Input Voltage	High-Level	V _{IH}	0.7V _{DD}		V _{DD}	V		
	Low-Level	V _{IL}	V _{SS}		0.3 V _{DD}			
Output Voltage	High-Level	V _{OH}	I _{OH} =-0.4mA	SO Terminal	4.0	4.97	V _{DD}	V
	Low-Level	V _{OL}	I _{OL} =+3.2mA		V _{SS}	0.11	0.4	
Output Voltage	High-Level	V _{OHP}	I _{OH} =-25mA	P1~P20 Terminals (Note)	V _{DD} -1.5	V _{DD} -0.5	V _{DD}	V
			I _{OH} =-15mA		V _{DD} -1.0	V _{DD} -0.3	V _{DD}	
			I _{OH} =-10mA		V _{DD} -0.5	V _{DD} -0.2	V _{DD}	
	Low-Level	V _{OLP}	I _{OL} =+25mA		V _{SS}	0.5	1.5	V
			I _{OL} =+15mA		V _{SS}	0.3	0.8	
			I _{OL} =+10mA		V _{SS}	0.2	0.4	

Note: Specified value represent output current per pin. When use, total current consideration and less than power dissipation rating operation should be required.

■ SWITCHING CHARACTERISTICS

(V_{DD}=4.5~5.5V, V_{SS}=0V, T_A =-20~75°C, unless otherwise specified)

PARAMETER	SYMBOL	TEST CONDITIONS	MIN	TYP	MAX	UNIT
Data Set-up Time	t _{SD}	DATA-CLK	20			ns
Data Hold Time	t _{HD}	CLK-DATA	20			ns
Set-up Time	t _{SSTB}	STB-CLK	30			ns
Hold Time	t _{HSTB}	CLK-STB	30			ns
Output Delay Time	t _{PD O}	CLK-SO			70	ns
	t _{PD PCK}	CLK-P1~P20			100	ns
	t _{PD PSTB}	STB-P1~P2			80	ns
	t _{PD PCLR}	CLR-P1~P20			80	ns
Max. Operating Frequency	f _{MAX}		5			MHz

Note: C_{OUT}=50pF

SWITCHING CHARACTERISTICS TEST WAVEFORM

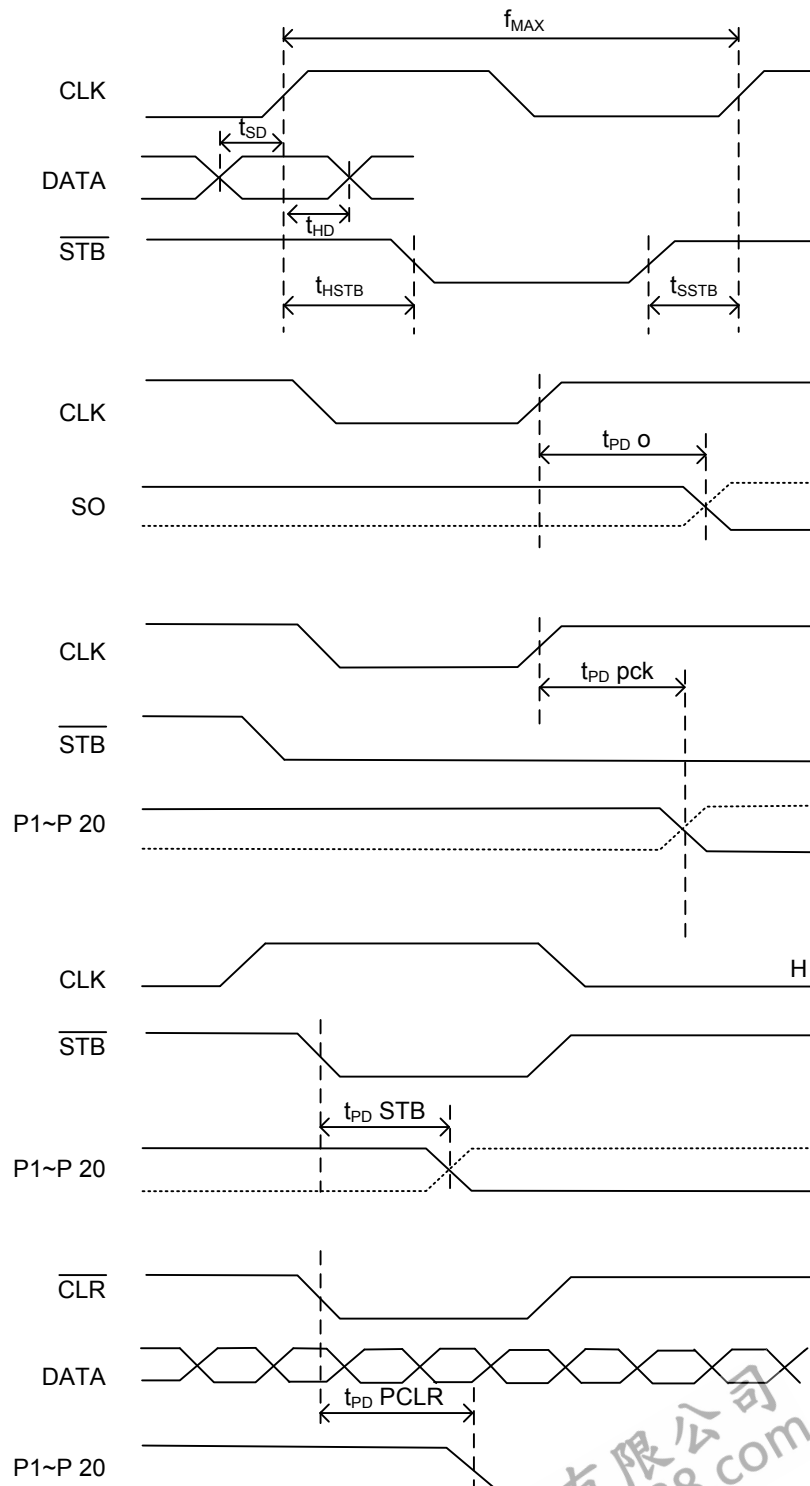

■ FUNCTION DESCRIPTION

RESET

When the $\overline{\text{CLR}}$ terminal is "L" level, all latches are reset and all of parallel output are "L" level. Normally, the $\overline{\text{CLR}}$ terminal should be "H" level.

DATA TRANSMISSION

When the $\overline{\text{STB}}$ terminal is "H" level and input the clock signal to the CLK terminal, the serial data input the DATA terminal and shift in the shift register by synchronizing at rising edge of the clock signal.



When the $\overline{\text{STB}}$ terminal is changed to "L" level, the data in the shift register are transferred to the latch.

Even if the $\overline{\text{STB}}$ terminal is "L" level, the input clock signal shift the data in the shift register, therefore, the clock signal controlled is needed.

CASCADE CONNECTION

The serial data input from DATA terminal and output from the SO terminal through internal shift register unrelated to the $\overline{\text{CLR}}$ and $\overline{\text{STB}}$ status.

Furthermore, the 4 input terminals have a hysteresis characteristic by using the schmitt trigger structure to decrease the noise.

CLK	$\overline{\text{STB}}$	$\overline{\text{CLR}}$	DESCRIPTION
X	X	L	All latch are reset (the data in the shift register is not change). All of parallel outputs are "L".
	H	H	The serial data input from DATA terminal to the shift register (the data in the latch is not change).
L	L	H	The data in the shift register transfer to the latch. And the data in the latch output from the parallel output.
H			
			The CLK input in the $\overline{\text{STB}}="L"$ and $\overline{\text{CLR}}="H"$ state, the data shift in the shift register and latched data also change in accordance with the shift register.

Note: X: Don't care

■ TIMING CHART

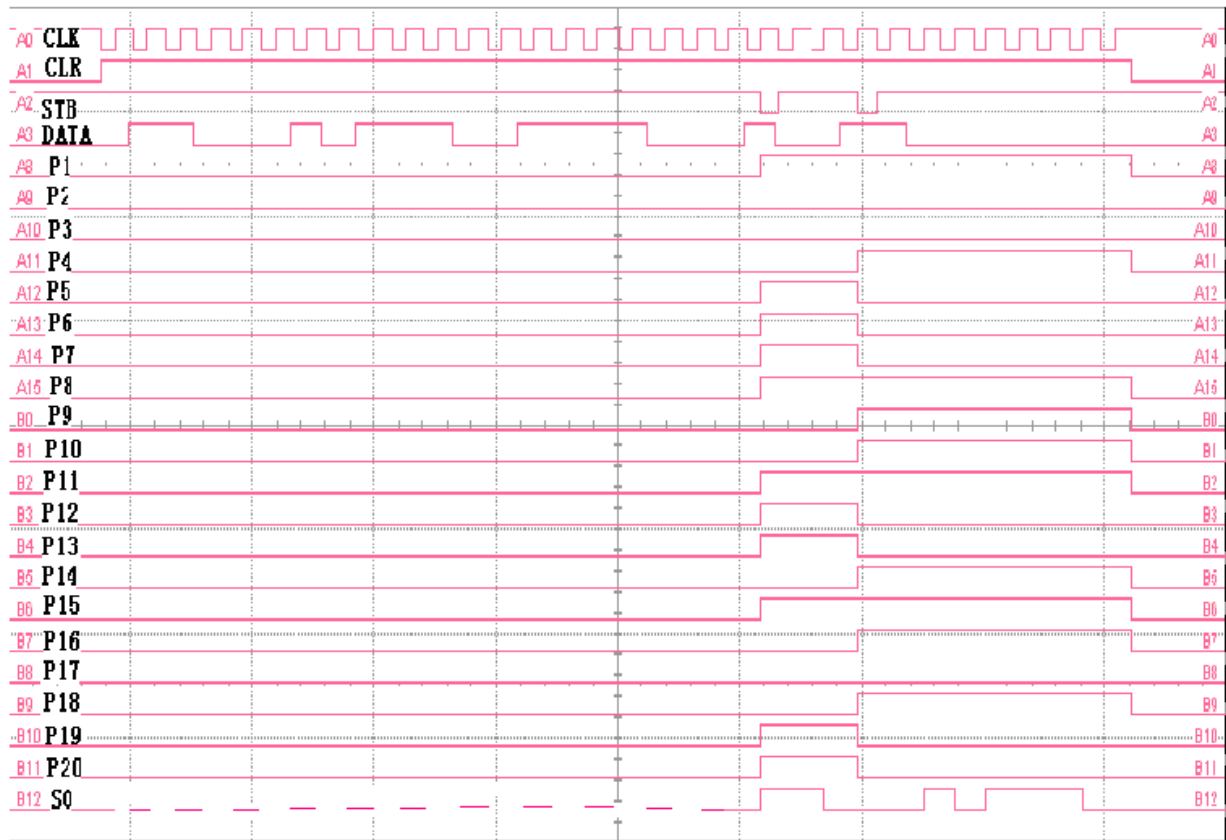

FLYING 汎翔國際有限公司
www.flying1688.com

■ TYPICAL APPLICATION CIRCUIT

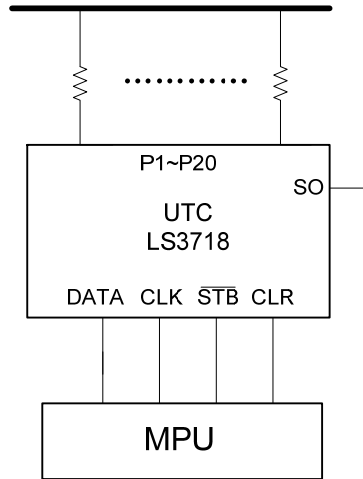

Cascade Connection

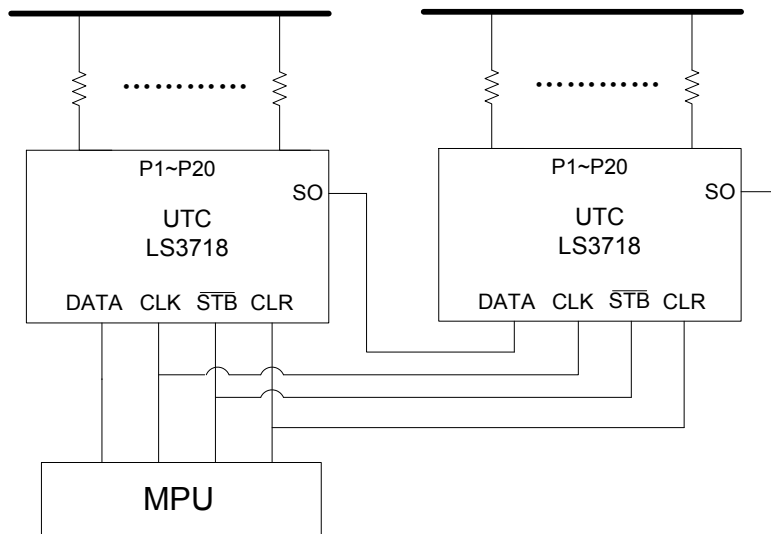

UTC assumes no responsibility for equipment failures that result from using products at values that exceed, even momentarily, rated values (such as maximum ratings, operating condition ranges, or other parameters) listed in products specifications of any and all UTC products described or contained herein. UTC products are not designed for use in life support appliances, devices or systems where malfunction of these products can be reasonably expected to result in personal injury. Reproduction in whole or in part is prohibited without the prior written consent of the copyright owner. The information presented in this document does not form part of any quotation or contract, is believed to be accurate and reliable and may be changed without notice.