



LV2464

Preliminary

LINEAR INTEGRATED CIRCUIT

FAMILY OF LOW-POWER RAIL-TO-RAIL INPUT/OUTPUT OPERATIONAL AMPLIFIERS

DESCRIPTION

The UTC LV2464 is a quad low-power rail-to-rail input/output op amplifier with low supply current (500uA/op) and low voltage (2.7-6V), that can be designed into a wide range of applications.

The UTC LV2464 has a guaranteed 1.6V/μs slew rate and low supply current. Rail-to-rail output and high output current make the IC's ideal for buffering analog-to-digital converters. And the input common-mode voltage range including ground and V_{CC}. Besides, they are also able to driving large capacitive loads.

Good AC performance can be provided because of 6.4MHz of bandwidth and 1.6V/μs of slew rate. Furthermore, low input noise voltage (11nV/√Hz) and low input offset voltage (100μV) make good DC performance.

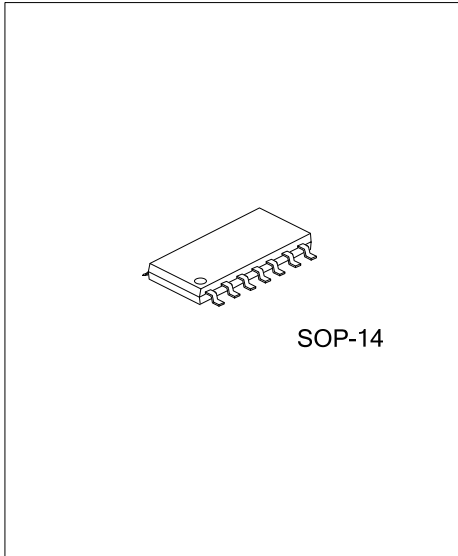

SOP-14

FEATURES

- * Rail-to-Rail Output Swing
- * ±48mA Output Drive Capability(V_{CC}=5V)
- * Gain Bandwidth Product: 6.4MHz
- * Supply Current: 500μA/channel
- * Input Offset Voltage: 100μV
- * Input Noise Voltage: 11nV/√Hz
- * Universal Operational Amplifier
- * Slew Rate: 1.6V/μs

ORDERING INFORMATION

Ordering Number		Package	Packing
Lead Free	Halogen Free		
LV2464L-S14-R	LV2464G-S14-R	SOP-14	Tape Reel

<p>LV2464G-S14-R</p> <p>(1)Packing Type</p> <p>(2)Package Type</p> <p>(3)Green Package</p>	<p>(1) R: Tape Reel</p> <p>(2) S14: SOP-14</p> <p>(3) G: Halogen Free and Lead Free, L: Lead Free</p>
--	---

MARKING

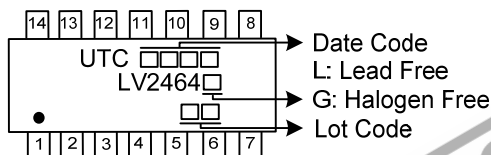

■ PIN CONFIGURATION

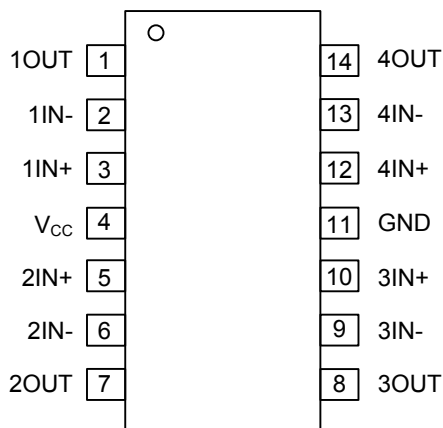

■ PIN DESCRIPTION

PIN NO.	PIN NAME	DESCRIPTION
1	1OUT	Output1
2	1IN-	Negative input1
3	1IN+	Positive input1
4	V _{CC}	Supply power
5	2IN+	Positive input2
6	2IN-	Negative input2
7	2OUT	Output2
8	3OUT	Output3
9	3IN-	Negative input3
10	3IN+	Positive input3
11	GND	Ground
12	4IN+	Positive input4
13	4IN-	Negative input4
14	4OUT	Output4

FLYING 汎翔國際有限公司
www.flying1688.com

■ BLOCK DIAGRAM

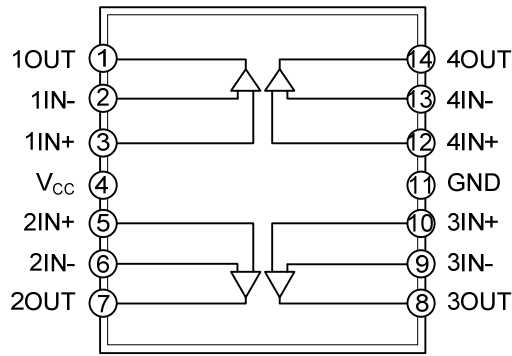

■ INTERNAL SIMPLE CIRCUIT

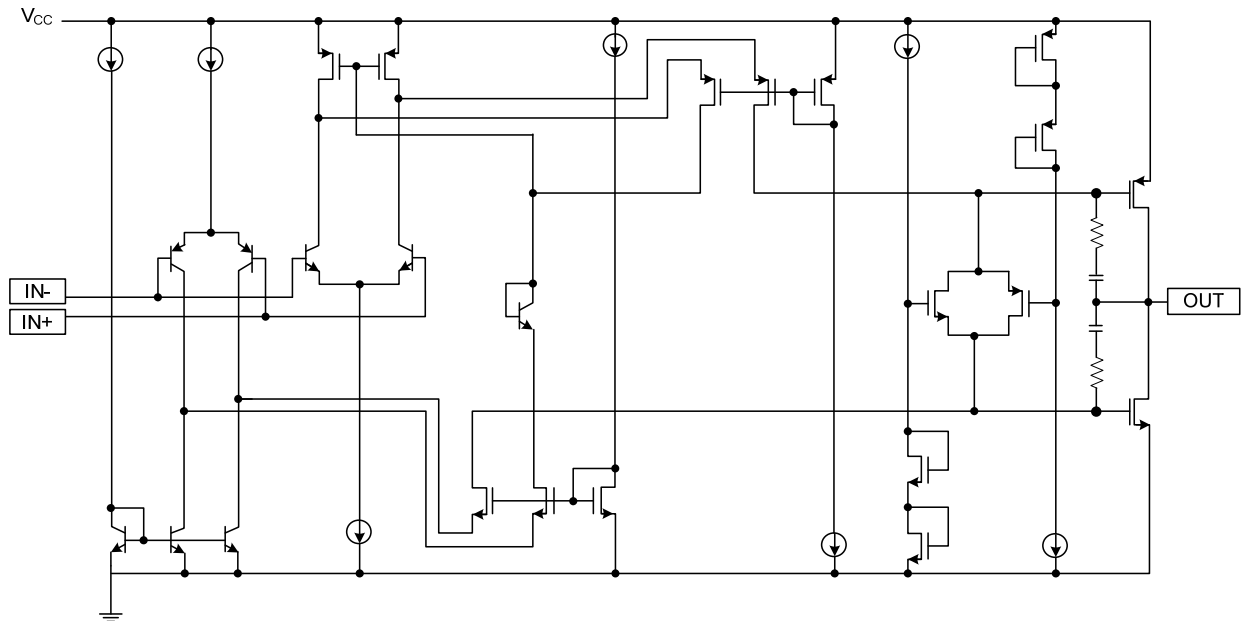

FLYING 汎翔國際有限公司
www.flying1688.com

■ ABSOLUTE MAXIMUM RATING ($T_A=25^{\circ}\text{C}$, unless otherwise specified)

PARAMETER	SYMBOL	RATINGS	UNIT
Supply Voltage (Note 2)	V_{CC}	6	V
Differential Input Voltage	V_{ID}	$-0.2 \sim V_{CC}+0.2$	V
Output Current	I_O	± 175	mA
Power Dissipation	P_D	1000	mW
Operating Free-Air Temperature	T_A	$-40 \sim +125$	$^{\circ}\text{C}$
Junction Temperature	T_J	+150	$^{\circ}\text{C}$
Storage Temperature	T_{STG}	$-60 \sim +150$	$^{\circ}\text{C}$

Notes: 1. Absolute maximum ratings are those values beyond which the device could be permanently damaged.

Absolute maximum ratings are stress ratings only and functional device operation is not implied.

2. All voltage values, except differential voltages, are with respect to GND.

■ THERMAL DATA

PARAMETER	SYMBOL	RATINGS	UNIT
Junction to Ambient	θ_{JA}	125	$^{\circ}\text{C}/\text{W}$
Junction to Case	θ_{JC}	27	$^{\circ}\text{C}/\text{W}$

■ RECOMMENDED OPERATING CONDITIONS

PARAMETER	SYMBOL	RATINGS	UNIT	
Supply Voltage	V_{CC}	Single supply	2.7 ~ 6	V
		Split supply	$\pm 1.35 \sim \pm 3$	V
Common-Mode Input Voltage	V_{ICR}	$0 \sim V_{CC}$	V	
Operating Free-Air Temperature	T_A	$-40 \sim +125$	$^{\circ}\text{C}$	

Note: Relative to voltage on the GND terminal of the device.

■ ELECTRICAL CHARACTERISTICS ($T_A=25^\circ\text{C}$, unless otherwise specified)

$V_{CC}=3\text{V}$ ($T_A=25^\circ\text{C}$, unless otherwise specified)

PARAMETER	SYMBOL	TEST CONDITIONS	MIN	TYP	MAX	UNIT
Input Offset Voltage	V_{IO}	$V_{CC}=3\text{V}$, $V_{IC}=1.5\text{V}$, $V_O=1.5\text{V}$, $R_S=50\Omega$		500	2000	μV
Input Offset Current	I_{IO}	$V_{CC}=3\text{V}$, $V_{IC}=1.5\text{V}$, $V_O=1.5\text{V}$, $R_S=50\Omega$		2.8	7	nA
Input Bias Current	I_{IB}	$R_S=50\Omega$		4.4	14	nA
High-Level Output Voltage	V_{OH}	$I_{OH}=-2.5\text{mA}$		2.9		V
		$I_{OH}=-10\text{mA}$		2.7		V
Low-Level Output Voltage	V_{OL}	$V_{IC}=1.5\text{V}$, $I_{OL}=2.5\text{mA}$		0.1		V
		$V_{IC}=1.5\text{V}$, $I_{OL}=10\text{mA}$		0.3		V
Short-Circuit Output Current	I_{OS}	Sourcing		50		mA
		Sinking		40		mA
Output Current	I_O	Measured 1V form rail		± 40		mA
Large-Signal Differential Voltage Amplification	A_{VD}	$R_L=10\text{k}\Omega$, $V_{O(PP)}=1\text{V}$	90	105		dB
Differential Input Resistance	$r_{i(D)}$	$T_A=25^\circ\text{C}$		10^9		Ω
Common-Mode Input Capacitance	$C_{i(C)}$	$f=10\text{kHz}$, $T_A=25^\circ\text{C}$		7		pF
Closed-Loop Output Impedance	Z_O	$f=100\text{kHz}$, $A_V=10$, $T_A=25^\circ\text{C}$		33		Ω
Common-Mode Rejection Ratio	CMRR	$V_{ICR}=0\sim 3\text{V}$, $R_S=50\Omega$	66	80		dB
Supply Voltage Rejection Ratio ($\Delta V_{CC}/\Delta V_{IO}$)	k_{SVR}	$V_{CC}=2.7\sim 6\text{V}$, $V_{IC}=V_{CC}/2$, No load	80	85		dB
		$V_{CC}=3\sim 5\text{V}$, $V_{IC}=V_{CC}/2$, No load	85	95		dB
Supply Current(per channels)	I_{CC}	$V_O=1.5\text{V}$, No load		0.5	0.575	mA
OPWERAING CHARACTERISTICS						
Slew Rate at Unity Gain	SR	$V_{O(PP)}=0.8\text{V}$, $R_L=10\text{k}\Omega$, $C_L=160\text{pF}$	0.9	1.6		V/ μs
Equivalent Input Noise Voltage	V_N	$f=100\text{Hz}$		16		nV/ $\sqrt{\text{Hz}}$
		$f=1\text{kHz}$		11		$\sqrt{\text{Hz}}$
Equivalent Input Noise Current	I_N	$f=1\text{kHz}$		0.13		pA/ $\sqrt{\text{Hz}}$
Total Harmonic Distortion Plus Noise	THD+N	$V_{O(PP)}=2\text{V}$, $R_L=10\text{k}\Omega$, $f=1\text{kHz}$	$A_V=1$	0.006		%
			$A_V=10$	0.02		%
			$A_V=100$	0.08		%
Gain-Bandwidth Product		$f=10\text{ kHz}$, $C_L=160\text{pF}$, $R_L=10\text{k}\Omega$		5.2		MHz
Setting Time	t_s	$V_{(STEP)PP}=2\text{V}$, $R_L=10\text{k}\Omega$, $A_V=-1$, $C_L=10\text{pF}$	0.1%	1.47		μs
			0.01%	1.78		μs
			0.1%	1.77		μs
			0.01%	1.98		μs
Phase Margin at Unity Gain	Φ_M	$R_L=10\text{k}\Omega$, $C_L=160\text{pF}$		44		$^\circ$
Gain Margin				7		dB

■ ELECTRICAL CHARACTERISTICS ($T_A=25^\circ\text{C}$, unless otherwise specified)

$V_{CC}=5\text{V}$ ($T_A=25^\circ\text{C}$, unless otherwise specified)

PARAMETER	SYMBOL	TEST CONDITIONS	MIN	TYP	MAX	UNIT	
Input Offset Voltage	V_{IO}	$V_{CC}=5\text{V}$, $V_{IC}=2.5\text{V}$, $V_O=2.5\text{V}$, $R_S=50\Omega$		500	2000	μV	
Input Offset Current	I_{IO}	$V_{CC}=5\text{V}$, $V_{IC}=2.5\text{V}$, $V_O=2.5\text{V}$, $R_S=50\Omega$		0.3	7	nA	
Input Bias Current	I_{IB}	$R_S=50\Omega$		1.3	14	nA	
High-Level Output Voltage	V_{OH}	$I_{OH}=-2.5\text{mA}$		4.9		V	
		$I_{OH}=-10\text{mA}$		4.8		V	
Low-Level Output Voltage	V_{OL}	$V_{IC}=2.5\text{V}$, $I_{OL}=2.5\text{mA}$		0.1		V	
		$V_{IC}=2.5\text{V}$, $I_{OL}=10\text{mA}$		0.2		V	
Short-Circuit Output Current	I_{OS}	Sourcing		145		mA	
		Sinking		100		mA	
Output Current	I_O	Measured 1V form rail		± 48		mA	
Large-Signal Differential Voltage Amplification	A_{VD}	$V_{IC}=2.5\text{V}$, $R_L=10\text{k}\Omega$, $V_O=1\sim 4\text{V}$	92	109		dB	
Differential Input Resistance	$r_{i(D)}$	$T_A=25^\circ\text{C}$		10^9		Ω	
Common-Mode Input Capacitance	$C_{i(C)}$	$f=10\text{kHz}$, $T_A=25^\circ\text{C}$		7		pF	
Closed-Loop Output Impedance	Z_O	$f=100\text{kHz}$, $A_V=10$, $T_A=25^\circ\text{C}$		29		Ω	
Common-Mode Rejection Ratio	CMRR	$V_{ICR}=0\sim 5\text{V}$, $R_S=50\Omega$	71	85		dB	
Supply Voltage Rejection Ratio ($\Delta V_{CC}/\Delta V_{IO}$)	k_{SVR}	$V_{CC}=2.7\sim 6\text{V}$, $V_{IC}=V_{CC}/2$, No load	80	85		dB	
		$V_{CC}=3\sim 5\text{V}$, $V_{IC}=V_{CC}/2$, No load	85	95		dB	
Supply Current (per channels)	I_{CC}	$V_O=2.5\text{V}$, No load		0.55	0.65	mA	
OPERATING CHARACTERISTICS							
Slew Rate at Unity Gain	SR	$V_{O(PP)}=2\text{V}$, $C_L=160\text{pF}$, $R_L=10\text{ k}\Omega$	0.9	1.6		$\text{V}/\mu\text{s}$	
Equivalent Input Noise Voltage	V_N	$f=100\text{Hz}$		14		$\text{nV}/\sqrt{\text{Hz}}$	
		$f=1\text{kHz}$		11		$\sqrt{\text{Hz}}$	
Equivalent Input Noise Current	I_N	$f=1\text{kHz}$		0.13		$\text{pA}/\sqrt{\text{Hz}}$	
Total Harmonic Distortion Plus Noise	THD+N	$V_{O(PP)}=4\text{V}$, $R_L=10\text{k}\Omega$, $f=1\text{kHz}$	$A_V=1$		0.004		%
			$A_V=10$		0.01		%
			$A_V=100$		0.04		%
Gain-Bandwidth Product		$f=10\text{ kHz}$, $C_L=160\text{pF}$, $R_L=10\text{k}\Omega$		6.4		MHz	
Setting Time	t_s	$V_{(STEP)PP}=2\text{V}$, $R_L=10\text{k}\Omega$ $A_V=-1$, $C_L=10\text{pF}$	0.1%		1.53		μs
			0.01%		1.83		μs
			0.1%		3.13		μs
			0.01%		3.33		μs
Phase Margin at Unity Gain	Φ_M	$R_L=10\text{k}\Omega$, $C_L=160\text{pF}$		45		$^\circ$	
Gain Margin				7		dB	

■ TYPICAL APPLICATION CIRCUIT

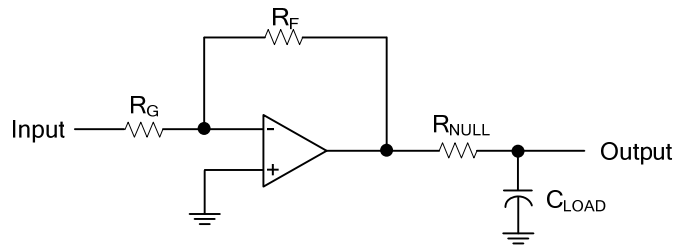

Driving A Capacitive Load

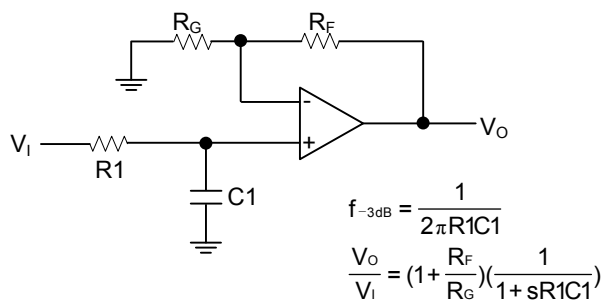

Single-Pole Low-Pass Filter

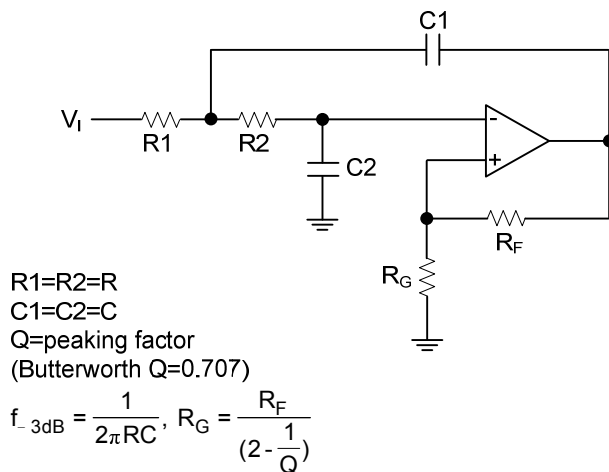

2-Pole Low-Pass Sallen-Key Filter

UTC assumes no responsibility for equipment failures that result from using products at values that exceed, even momentarily, rated values (such as maximum ratings, operating condition ranges, or other parameters) listed in products specifications of any and all UTC products described or contained herein. UTC products are not designed for use in life support appliances, devices or systems where malfunction of these products can be reasonably expected to result in personal injury. Reproduction in whole or in part is prohibited without the prior written consent of the copyright owner. UTC reserves the right to make changes to information published in this document, including without limitation specifications and product descriptions, at any time and without notice. This document supersedes and replaces all information supplied prior to the publication hereof.